



**Soil and Water Management Plan including
Stormwater Management Scheme, Site Water Balance and Erosion
and Sediment Control for Stage 1 Northbank Enterprise Hub
(WesTrac Facility) at Lot 212 and Part Lot 211 DP 1174939 WesTrac
Drive, Tomago NSW**

Revision F

Prepared for Northbank Enterprise Hub Pty Ltd

16 December 2025

Document Control Sheet

Issue No.	Amendment	Date	Prepared by	Checked by
A	Issue for review	11/12/09	Scott Day	Lincoln Gibbs
B	Issue for submission	14/12/09	Scott Day	
C	DoP & DEWHA amendments	29/01/10	Scott Day	
D	Mod 3, MTDA as shown	7/12/22	Nathan Delaney	Scott Day
E	Revised Surface Water Monitoring	04/03/25	Nathan Delaney	Scott Day
F	Minor amendments as requested by DCCEEW	16/12/25	ADW Johnson/ Torque Projects	Torque Projects

Declaration of accuracy

In making this declaration, I:

- a) am aware that section 491 of the *Environment Protection and Biodiversity Conservation Act 1999* (EPBC Act) makes it an offence in certain circumstances to knowingly provide false or misleading information or documents to specified persons who are known to be performing a duty or carrying out a function under the EPBC Act or the *Environment Protection and Biodiversity Conservation Regulations 2000* (EPBC Regulations). The offence is punishable on conviction imprisonment or a fine, or both.
- b) am authorised to bind Northbank Enterprise Hub Pty Ltd to this declaration and have no knowledge of that authorisation being revoked at the time of making this declaration.

Signature	
Full name (please print)	Steve Robson
Organisation (please print)	Northbank Enterprise Hub Pty Ltd
Date	17 / 12 / 25

Executive Summary

ADW Johnson Pty Limited was engaged by WEPL Investments Pty Ltd to complete the Soil and Water Management Plan (SWMP) for the proposed WesTrac facility being Stage 1 of the approved Part 3A project, Project No. 07_0086 at Tomago Road, Tomago.

The Stage 1 project has been operating since July 2012. Douglas Partners Pty Limited has been engaged by Northbank Enterprise Hub Pty Limited to review and provide an updated, contemporary monitoring section to the Stage 1 Soil and Water Management Plan (**SWMP**). Torque Projects Pty Limited has completed the monitoring section replacement and addressed minor comments from DCCEEW to complete a revised SWMP replaces the existing SWMP.

NEH and WesTrac are dedicated to ensuring that Stage 1 is environmentally responsible given its location to a sensitive environment and as a result have insisted on an advanced stormwater management strategy for the WesTrac facility at Tomago. The SWMP includes stormwater harvesting and recycling to meet on site water demands, whilst providing protection to mitigate any potential stormwater impacts on the downstream receiving environment.

The site is located upslope and north of the Kooragang Nature Reserve adjacent to the Hunter River. There are two (2) distinctly different soil conditions across the site. The northern half of the site is Aeolian sands whereas the southern half is floodplain clays overlying a deeper sand layer. At the clay/sands interface, regional groundwater flows from the north and Tomago Sandbeds overflow onto the surface, discharging through the site as surface water flows. These are conveyed through the site via a series of farm drains that were constructed to improve the land for agricultural purposes.

The SWMP is practical, functional and compliant with Department of Planning and Environment Protection and Biodiversity Conservation Act approvals. Furthermore, we have consulted with National Parks & Wildlife Service (**NPWS**), the managers of the downstream land – Kooragang Nature Reserve. The SWMP has been developed to suit NPWS needs as closely as possible.

The stormwater approach is an advanced water sensitive design. Stormwater runoff from roof areas is harvested for reuse in site operations. The extent of reuse has been maximised. Stormwater runoff from hardstand paved areas is treated and then distributed to groundwater via Caisson wells or directed to the constructed wetland for storage and treatment by retention before discharge as surface water from the constructed wetland, replicating existing conditions. A comprehensive stormwater monitoring plan is proposed for the quality and quantity of surface water discharge from the constructed wetland. Similarly, Douglas Partners has provided a detailed groundwater monitoring plan for discharges to regional groundwater.

The SWMP has flexibility for ongoing adjustment and adaptation to site conditions after operations commence as a result of the discharge monitoring outcomes. The initial system setting has significant capacity for containment of very large storm events within a large constructed wetland and only low flow drawdown, over a maximum period of 48 hours, as surface water discharge. This is designed to replicate existing, pre development conditions as closely as possible and in most storms will be an improvement to downstream conditions. The adjustments available

are weir and outflow of the constructed wetland and optional adjustment for re-proportioning groundwater and surface water discharges from the site.

Roofwater is collected in a 2ML rainwater tank and used for Dyno/Transmission Testing, Washpads, toilet flushing, display pond top up and irrigation of the landscaped areas. Hardstand runoff will be collected in piped drainage with gross pollutant traps as the standard pre treatment of stormwater runoff. Hardstand runoff and any overflow from the rainwater tank discharges are to the bioretention trenches in perimeter swale drainage. Discharge is then to regional groundwater flows in deeper sands via Caisson wells. After the capture volume in the bioretention trench has been reached, stormwater bypasses to the constructed wetland. The surface area of the constructed wetland is 1.9 hectares, providing significant storage capacity and evaporative surface area. Modelling of the discharges to groundwater via Caisson wells and surface water discharge from the constructed wetland indicate compliance with Department of Environment and Climate Change (DECC) water quality objectives. Groundwater and surface water will be monitored.

The stormwater system has been designed to comfortably attenuate peak flows from multiple design storms ranging from an Average Recurrence Interval (**ARI**) of 1 in 1 year through to an ARI of 1 in 100 year storm events. Significant attenuation is provided in the constructed wetland to maximise evaporative opportunity and additionally more closely match the needs of NPWS. Modelling indicates that the post development peak discharges are significantly attenuated, mostly by an order of magnitude when compared to the existing peak flows.

Site water balance modelling does indicate that during an average annual rainfall year there will be a marginal increase of surface water quantity discharged to the south. This is being effectively managed by providing significant permanent water storage capacity, discharge occurring within a 48 hour period of rainfall, maintaining peak discharges within existing limits, only discharging larger stormwater quantities over the spillway outlet of the constructed wetland during large storm events when the downstream areas are already saturated with freshwater and providing flexibility in the stormwater system for ongoing adjustment. Surface water flows will be monitored.

Erosion and sediment controls were implemented during construction. These were necessary for the protection of receiving waters downstream when the site surface is disturbed. The constructed wetland will be established early as a sediment basin. Erosion and sediment control measures are temporary, and are required until such time that the building and construction areas are landscaped, revegetated and sealed. The systems of sediment controls proposed in the SWMP at the WesTrac Facility Tomago exceed industry standards for compliance.

Table of Contents

1.0	INTRODUCTION & COMPLIANCE REQUIREMENTS	1
2.0	SITE DESCRIPTION	13
3.0	DEVELOPMENT DESCRIPTION	14
4.0	CONSULTATION	15
5.0	MODIFICATIONS TO PROJECT APPLICATION STORMWATER PLAN	17
6.0	SITE WATER BALANCE	21
6.1	Objectives.....	21
6.2	Regional Context to Water Balance.....	21
6.3	Operations Water Balance Parameters and Characteristics.....	22
6.4	Summary of Results	25
6.5	Contingency/Flexibility Options.....	27
7.0	EROSION AND SEDIMENT CONTROL PLAN	29
7.1	Erosion and Sediment Control.....	30
7.2	Land Disturbance Conditions.....	30
7.3	Construction Sequence.....	31
7.4	Sediment Control Conditions	31
7.5	Site Maintenance Requirements.....	32
8.0	STORMWATER MANAGEMENT SCHEME	33
8.1	Strategy.....	33
8.2	Water Quality	33
8.2.1	Washpads	34
8.2.2	Water Quality Modelling	35
8.3	Peak Discharges.....	39
8.3.1	Rainfall Data	39
8.3.2	Calibration	40
8.3.3	RAFTS Modelling Parameters	41
8.3.3	RAFTS Peak Discharge Estimates.....	43
8.3.4	Downstream Capacity.....	46
8.4	Miscellaneous Drainage Components	47
8.4.1	Fill Elevation.....	47
8.4.2	Fill Quality	48
9.0	MANAGEMENT, MONITORING AND REPORTING.....	49

9.1	Water Management.....	49
9.1.1	Rainwater Tank & Buildings.....	49
9.1.2	Trunk Drainage System.....	49
9.1.3	Operation and Maintenance.....	49
9.2	Monitoring Strategy.....	51
9.3	Reporting.....	51
10.0	REFERENCES.....	52
	FIGURES.....	53

APPENDICES

APPENDIX A – BMT WBM Letter Review for NPWS

APPENDIX B – “Report on Assessment of Proposed Stormwater Infiltration” by Douglas Partners

APPENDIX C – Sediment Basin calculations

APPENDIX D – Inspection Checklist

APPENDIX E – Addendum No.1 dated Feb 2011

APPENDIX F – “Report on Revised Surface Water Monitoring Procedure” by Douglas Partners

1.0 Introduction & Compliance Requirements

ADW Johnson Pty Limited has been engaged by WEPL Investments Pty Ltd to complete the stormwater management plan for the proposed WesTrac facility being Stage 1 of Project No. 07_0086 at Tomago Road, Tomago. NEH and WesTrac are dedicated to ensuring that their developments are environmentally sensitive and as a result have insisted on advanced stormwater management for the WesTrac facility. The stormwater management plan includes stormwater harvesting and recycling to meet on site water demands, whilst providing protection to mitigate any potential stormwater impacts on the downstream receiving environment.

This plan addresses the development consent requirements of site water balance, erosion and sediment control and the stormwater management scheme for the WesTrac facility site – Stage 1 of the approved development.

The SWMP is practical, functional and compliant with requirements. We have consulted with National Parks & Wildlife Service (NPWS), the managers of the downstream land. We have designed the SWMP to suit NPWS needs wherever possible.

The Stage 1 project has been operating since July 2012. Douglas Partners Pty Limited has been engaged by Northbank Enterprise Hub Pty Limited to review and provide an updated, contemporary monitoring section to the Stage 1 Soil and Water Management Plan (**SWMP**). Torque Projects Pty Limited has completed the monitoring section replacement and addressed minor comments from DCCEEW to complete a revised SWMP replaces the existing SWMP.

The SWMP has flexibility for adjustment and adaptation to site conditions as a result of the discharge monitoring outcomes after operations commence. The initial system setting proposed has significant capacity for containment of very large storm events within the constructed wetland and only low flow drawdown as surface water discharge. This is designed to replicate existing, pre development conditions as closely as possible. A proportion of discharge, following treatment will be to a sand layer beneath the floodplain clays via infiltration, replicating existing, predevelopment conditions. A Groundwater Monitoring Plan is proposed to monitor the quality and quantity of these groundwater discharges. A stormwater monitoring plan is proposed for these surface water discharges in order to monitor the quality and quantity of stormwater discharging from the constructed wetland.

Following the establishment of operations and monitoring of the system, there is flexibility designed into the perimeter drainage and constructed wetland inlets and outlets to adjust for the upgrade or downgrade of stormwater storages and discharge proportions to surface water or groundwater, relative to the monitored results and predicted modelling outcomes. A cautious approach to stormwater discharges is required by NEH, and therefore significant contingency and risk protection has been included into the SWMP.

The NSW Department of Planning (**DoP**) issued project application approval that comprised consent conditions and Asquith & deWitt's (now ADW Johnson) Statement of Commitments compiled within the Environmental Assessment. Asquith & deWitt previously completed "Volume 3 – Stormwater Management Report – WesTrac facility", Version 1, November 2007 for the project application. The Director General's Environmental Assessment Report has been used as a guide to determine the intended amendments required to the existing stormwater management regime to address issues raised as part of the Director General's Environmental Assessment.

The Australian Government Department of the Environment, Water, Heritage and the Arts also issued the Environment Protection Biodiversity Conservation (**EPBC**) Approval 18 November 2009, EPBC Ref 2007/3343. The conditions raised in the approval have also been addressed in this SWMP.

In summary, a compliance checklist has been prepared to identify the requirements and the section reference for its address. The consent requirements and statement of commitments are shown below in **Tables 1, 2 & 3** respectively.

Table 1 – Development Consent Requirements and Section Reference

Requirement Description	Section reference/ Comment
<p>9. The Site Water Balance must:</p> <p>(a) include details of:</p> <ul style="list-style-type: none"> • Sources and security of water supply; • Water use/re-use on site; • Water management on site; • Reporting procedures; <p>(b) describe measures to minimise potable water use by the project and maximise reuse of rainwater harvested from the site; and</p> <p>(c) be reviewed and recalculated each year in light of the most recent water monitoring data.</p>	<p>6.3 6.3 9.1 9.3</p> <p>6.3</p> <p>9.3</p>
<p>10. The Erosion and Sediment Control Plan must:</p> <p>(a) be consistent with the requirements of Landcom’s (2004) Managing Urban Stormwater: Soils and Construction;</p> <p>(b) identify the activities on site that could cause soil erosion and generate sediment; and</p> <p>(c) describe what measures would be implemented to:</p> <ul style="list-style-type: none"> • Minimise soil erosion and the transport of sediment to downstream waters, including the location, function and capacity of any erosion and sediment control structures; and • Maintain these structures over time. 	<p>7.0</p> <p>7.0</p> <p>7.1</p> <p>7.5</p>
<p>12. The Stormwater Management Scheme must:</p> <p>(a) be prepared in consultation with Council and DECC;</p> <p>(b) be prepared in accordance with DECC’s Managing Urban Stormwater guidelines and HCCREMS Water Sensitive Urban Design Solutions for Catchments Above Wetlands;</p> <p>(c) demonstrate that post development flows will not exceed predevelopment flows for a range of ARI from 1 year up to and including 100 year ARI;</p> <p>(d) investigate alternative options to avoid discharges to the adjoining wetlands to the south of the site;</p> <p>(e) demonstrate that the existing stormwater drainage channels have capacity to accommodate post development flows under a range of tidal conditions;</p>	<p>4.0</p> <p>8.2.2 (DECC), 6.3 (HCCREMS)</p> <p>8.3</p> <p>6.2, 6.5</p> <p>8.3.4</p>

Requirement Description	Section Comment	reference/
(f) demonstrate that the extended detention depth of the infiltration area allows vegetation growth and minimises groundwater mounding;		Appendix B
(g) include provision for the drainage flow paths for culverts under Tomago Road through the site;		Figure 9
(h) includes details of the: <ul style="list-style-type: none"> • Stormwater detention (capacity and location), • Treatment and control infrastructure including pre-treatment for the infiltration area to reduce sediment and nutrient loads, the drainage design for the disposal of stormwater off-site and the method of controlled release from the site; and • Measures to monitor and maintain the stormwater treatment and control infrastructure; and 		8.3.3 8.2
(i) Include a program to monitor stormwater quantity (including inflows, outflows and bypass flows) and quality (including but not limited to total suspended solids, total phosphorus and total nitrogen) during operation of the project.		9.1 9.2

Table 2 - Statement of Commitments Requirements and Section Reference

Requirement Description	Section Comment	reference/
<p>8.7 WATER QUALITY</p> <p>Water quality measures will be installed in accordance with the Stormwater Management Report prepared by Asquith & de Witt, included in this SWMP as Appendix F (to the EA).</p> <p>The water quality objective for the site was to determine a solution of 'no impact' to the downstream receiving waters. The MUSIC (Model for Urban Stormwater Improvement Conceptualisation) model was established to verify the quantity of the run off to the wetlands for 'no impact', post development. Reuse, a treatment train, gross pollutant trap, swale and constructed wetland was sized to meet the target objective verified with MUSIC.</p>		

Requirement Description	Section reference/ Comment
<p>Water quality will be monitored, and a management plan, as detailed in the Flora & Fauna Report prepared by Ecobiological contained at Appendix J (to the EA), will be prepared to address the construction and operational phases. More specifically this management plan will include:</p> <ul style="list-style-type: none"> • The nature and control of sediment run-off during the construction phase particularly as a result of an exceptional storm event; • The chemical content of the fill and of the groundwater seepage from that fill that would disperse into the wetlands over the long term; • The volume, path and content of stormwater discharging from the site during and after development; • The handling of hydrocarbon waste from the site during construction and operation stages; • Existing flow regime of subsurface and groundwater flow from the subject site into the wetlands; • At times of peak rainfall, sub-surface drainage through the fill is likely to discharge into the wetland – what will be the impact of the development on the quality of this water; • The current ecological character of the wetland in the immediate vicinity of the potential impact area; and • The impact of weed invasion during and after construction phase. 	<p>7.0</p> <p>8.4.2</p> <p>8.2, 8.3</p> <p>9.2.5 Appendix B – Douglas Partners</p> <p>8.4.2</p> <p>Ecobiological Report – separate cover</p> <p>9.1</p>
<p>A monitoring plan will also be put in place to document the ongoing water quality status, measured against an established baseline.</p>	<p>Refer to the revised monitoring plan prepared by Douglas Partners and contained in Appendix F of the SWMP</p>
<p>All products stored on-site having the potential to contaminate stormwater in the event of spillage will also be contained within a bounded area to the requirements of DECC.</p>	<p>Building Code requirement</p>
<p>STORMWATER CONTROLS Water quality control on site will be 2 proposed washpads. All vehicles and parts requiring washing will be taken to one of these, and no washing outside of these washpads will occur. WesTrac has standardised control over these facilities country wide at its</p>	<p>8.2.1</p>

Requirement Description	Section reference/ Comment
existing operations.	
A Construction Management and Environmental Management Plan will be prepared to manage potential water quality issues and submitted as required prior to construction or commencement of operations.	ADW Johnson – separate cover
The stormwater treatment train will be used for removal of the pollutants from the stormwater runoff prior to discharging to the wetlands downstream.	8.2
Gross Pollutant Traps will be installed at the entry to each of the constructed wetlands as a proprietary product for screening of heavy sediment and litter.	8.2
A large open channel swale drain has been designed into the development layout for street drainage, drainage of the intersection and secondary flows during major storm events. End of line treatment basins have been spread over the site to reduce the distances drainable for stormwater runoff.	Figure 9
Basins have been located to have discharge outlets to the existing discharge points from the site along the southern boundary, post development.	Figure 9
The site will be filled for development of the subdivision to a level that is flood free.	8.1, 8.4.1
Geotechnical approval will be obtained on the fill type and its properties prior to being used on the site. However the preferred fill type is granular material with particles not greater than 100mm diameter. The fill will be pH neutral and will be screened for properties under the supervision of geotechnical engineers, prior to supply to the site. No ash will be used for filling.	8.4.1
<p>SOIL AND WATER MANAGEMENT PLAN</p> <p>The sediment basins have been designed for settlement of Type F soils. A higher criteria level of protection has been adopted for the design sizing of the sediment basins, reflecting the sensitivity of the receiving waters downstream. The 95th percentile, 5 day rainfall event has been selected as the standard for this site, which provides an increased capacity to capture runoff and minimised the potential risk of sediment laden water leaving the site and discharging to the wetlands.</p>	7.0
Access is to be limited to the designated all weather roads, any truck exiting out of the site shall be thoroughly cleaned and limit the exportation of clay and sediment on public roads, and entry is prohibited on remaining land.	Figure 8, 7.2
<p>Works shall be undertaken in the following construction sequence:</p> <ol style="list-style-type: none"> 1) Install sediment fencing and cut drains to meet the requirements of the SWMP. Waste collection bins shall be 	7.3

Requirement Description	Section Comment reference/
<p>installed adjacent to site office.</p> <ol style="list-style-type: none"> 2) Construct stabilised site access in location nominated by the Contractor and in accordance with Port Stephens Council's requirements. 3) Construct sediment basins for disturbed areas in accordance with the rate per hectare provided in the SWMP. Install risers and two pegs in the floor of the basin and have them marked to show the top of the sediment storage zone. Ensure the basin is cleared of sediment once the design capacity is reached. 4) Redirect clean water around the construction site. 5) Install sediment control protection measures at all natural and man-made drainage structures. Maintain until all the disturbed areas are stabilised. 6) Clear and strip the work areas in accordance with the Geotechnical advice provided. 7) Any disturbed areas, other than lot grading areas, shall immediately be covered with site topsoil within 7 days of clearing. Lot re-graded shall be covered with bitumen emulsion as specified. 8) Apply permanent stabilisation to site (landscaping). 	<p>7.3 Figures 7 & 8</p>
<p>Sediment control conditions will include the following:</p> <ul style="list-style-type: none"> - Proprietary sediment fencing shall be installed by the Contractor in accordance with their approved SWMP and elsewhere at the discretion of the site superintendent to contain sediment fractions as near as possible to their source. - Sediment removed from any trapping device shall be relocated where further pollution to down slope lands and waterways cannot occur. - Stockpiles shall be located by the Contractor in accordance with their approved SWMP and elsewhere at the discretion of the site superintendent. Where stockpiles are to be in place longer than 30 days they shall be stabilised by covering with mulch or with temporary vegetation. - Water shall be prevented from entering the permanent drainage system unless it is sediment free. Drainage pits are to be protected in accordance with the Contractor's approved SWMP. - Temporary sediment traps at pits shall be retained until after lands they are protecting are completely rehabilitated. - Dust suppression will be required for the control of 	<p>7.4 Figures 7 & 8</p>

Requirement Description	Section reference/ Comment
<p>airborne particles during construction. This will be via standard water cart usage during earthworks and pavement construction of the hardstand areas.</p>	
<p>Site maintenance requirements include the following:</p> <ul style="list-style-type: none"> - Waste bins are to be provided for all construction refuse. They are to be emptied at least weekly and refuse is to be disposed in accordance with the site manager’s recommendations. - The site manager shall inspect the site at least weekly and shall: <ul style="list-style-type: none"> o Ensure that all drains are operating effectively and shall make any necessary repairs; o Remove any spilled material from area subject to runoff or concentrated flow; o Remove trapped sediment where the capacity of the trapping device falls below 60%; o Inspect the sediment basins after each rainfall even and/or weekly. Ensure that all sediment is removed once the sediment storage zone is full. Ensure that outlet and emergency spillway works are maintained in a fully operational condition at all times; o Ensure rehabilitated lands have effectively reduced the erosion hazard and initiate upgrading or repair as appropriate; o Construct additional erosion and sediment control works as may be appropriate to ensure the protection of down slope lands and waterways; o Maintain erosion and sediment control measures in a fully functioning condition at all times until the site is rehabilitated; o Ensure that the revegetation scheme is adhered to and that the all grass covers are kept healthy, including watering and mowing; and o Remove temporary soil conservation structures as the last activity in the rehabilitation program. 	<p>7.5 Figure 8</p>
<p>8.8 FLOW REGIME The proposed development will comply with the water balance prepared by Asquith & de Witt of Appendix F (of the EA). The water balance model outcomes will be complied with and</p>	

Requirement Description	Section reference/ Comment
intend to provide the following:	
A water balance model including recycling, uses and quantities associated with the operation of the WesTrac facility, as a guide for WesTrac;	6.4
An estimate for the rainwater storage requirements to ensure water security for the project;	6.3
An estimate of recharge to the HWC Special Area;	5.0
An estimate of the quantity of runoff discharging to the wetlands downstream; and	6.4
An identification of the expected key risks to water management based on the outcomes of the water balance.	6.5
<p>8.9 WATER REUSE</p> <p>The proposed development will comply with the water harvesting and recycling plan outlined in the Stormwater Management Report prepared by Asquith & de Witt, included at Appendix F (of the EA). More specifically, the washpads proposed on site for the purpose of cleaning heavy vehicle equipment prior to workshop activities will be the primary water quality control on site. The process will involve using a biodegradable detergent which releases free oil after addition of an emulsion breaker for efficient oil separation and collection, together with a detergent stripping stage using a foam fractionator. The resultant treated water will be recycled through a filtration and sterilisation stage. A portion of treated water is removed from the circuit and sent for final treatment to the site sewage treatment plant.</p>	8.2.1
<p>Water for washpad operations is derived from three (3) sources: Rainwater harvesting; Town water; and Recycled water.</p>	8.2.1
<p>The resultant wastewater will be pumped to a settling tank after dosing with a primary flocculant. The primary flocculant dose breaks all emulsions and presents free oil and wastewater to the skid mounted oil/water separator. Oil/water separation is achieved using a heavy duty coalescing plate separator.</p>	8.2.1
<p>Wastewater produced by the separator is further treated by a foam fractionator.</p>	8.2.1
<p>The treated washpad wastewater will be recycled after surfactant removal. Recycled water undergoes further treatment using chlorination and sand filtration. The recycled water feeds a low pressure wash unit with inline UN sterilisation. The spent washwater drains to the solids sump at the start of processing for</p>	8.2.1

Requirement Description	Section reference/ Comment
reuse.	
<p>8.10 SOIL EROSION AND SEDIMENTATION</p> <p>Erosion and sedimentation controls will be installed in accordance with the Stormwater Management Report prepared by Asquith & de Witt and enclosed at Appendix F (of the EA).</p> <p>More specifically, measures to be implemented during construction include:</p>	7.0
Disturbance only of areas to be immediately worked on and regeneration of dust and erosion free surfaces – landscaping, concrete, bitumen sealing as soon as practical thereafter.	7.1
Provision of and continued maintenance of sediment fencing to low perimeter locations.	7.1
Provision of mesh and gravel or geotextile inlet filters.	7.1
Contract specifications requiring stabilised site access, low flow earth flow earth banks and wind erosion screens.	7.1
A construction programme that provides for the sediment basin to be constructed at the outset with all site runoff, where practical, piped or channelled to this basin for primary treatment/settlement before leaving the site via a mesh supported geotextile filter/riser before discharging to the wetlands.	7.1
Contract specifications requiring regular maintenance of all erosion and sediment control structures and devices for the full contract and maintenance period.	7.1
<p>Furthermore, sediment control conditions will include the following:</p> <p>Proprietary sediment fencing shall be installed by the Contractor in accordance with their approved SWMP and elsewhere at the discretion of the site superintendent to contain sediment fractions as near as possible to their source.</p> <p>Sediment removed from any trapping device shall be relocated where further pollution to down slope lands and waterways cannot occur.</p> <p>Stockpiles shall be located by the Contractor in accordance with their approved SWMP and elsewhere at the discretion of the site superintendent. Where stockpiles are to be in place longer than 30 days they shall be stabilised by covering with mulch or with temporary vegetation.</p> <p>Water shall be prevented from entering the permanent drainage system unless it is sediment free. Drainage pits are to be protected in accordance with the Contractor’s approved SWMP.</p> <p>Temporary sediment traps at pits shall be retained until after lands they are protecting are completely rehabilitated.</p> <p>Dust suppression will be required for the control of airborne</p>	7.4

Requirement Description	Section reference/ Comment
particles during construction. This will be via standard water cart usage during earthworks and pavement construction of the hardstand areas.	

Table 3 – EPBC Requirements and Section Reference

Requirement Description	Section reference/ Comment
<p>In order to minimise potential significant impacts on the Hunter Estuary Ramsar Wetland site, prior to any commencement of works for each stage the person taking the action must submit to the Minister for approval a stormwater and groundwater management plan for that stage. Works must not commence until the plan is approved by the Minister. The approved plan must be implemented and address the following matters:</p> <ul style="list-style-type: none"> a. Documented industry best practice water sensitive design principles and practices; b. A review of the environmental values and water quality objectives for the Hunter Estuary Wetlands Ramsar site; c. Replication of natural surface and groundwater flows and water quality; d. Protection of the environmental values of receiving waters, including the Hunter Estuary Wetlands Ramsar site; and e. The principle of continuous improvement. 	<p>6.3 4.0 Appendix B, 8.2.2 4.0 6.5,9.3</p>
<p>The plan must include but not be limited to the following elements:</p> <ul style="list-style-type: none"> a. The water treatment management practices and management practice treatment trains that will be used to achieve or exceed environmental performance targets as detailed in the final Redlake Enterprises Pty Ltd – Tomago Road, Tomago – Environmental Assessment Report dated 12 March 2008 “Concept Engineering, Servicing, Earthworks and Stormwater Management” Appendix F(of the EA). b. How attainment of water quality objectives for these receiving waters will be supported by the action; c. How monitoring activities will be undertaken to track environmental performance of the action; and d. Groundwater and surface water monitoring must be undertaken pre, during and post development. This monitoring must continue until the Minister notifies that the construction and operation of this action is not impacting on the Hunter Estuary Wetlands Ramsar site. <p>If water quality measurements exceed the trigger levels set under</p>	<p>8.2.2 8.2.2 8.5 Groundwater Monitoring – separate cover, Surface water Monitoring – 9.2</p>

Requirement Description	Section reference/ Comment
the stormwater and groundwater management plan then works must stop immediately and the exceedance reported to the Minister within 7 days of detecting the exceedance. Failure to stop works and notify the Minister will be considered a breach of these conditions.	

2.0 Site Description

The WesTrac facility will occupy approximately 25.9 hectares within the overall subject land to be developed, of Lot 161 DP 774440, Lot 1 DP 1003492, Lot 1 DP 597372 and Lot 513 DP 585256. This area will accommodate the WesTrac facility, constructed wetland and associated road and trunk drainage infrastructure. Refer to **Figure 1**.

The land is located on the northern floodplain of the Hunter River on the southern side of Tomago Road, Tomago. Topographically, the site comprises a low dunal formation up to 8.5m AHD across the northern half of the site and a flat, low lying alluvial plain at an elevation of 0.5-1.5m AHD across the southern half of the site. These comprise distinctly different soil types and conditions, being sand and waterlogged clays respectively. Refer to **Figure 2**.

The low-lying portion of the site is waterlogged, generally covered with standing water 0.1-0.3m deep along the proposed southern boundary of the WesTrac facility. Open channel farm drains have been previously excavated into the site, and drain toward the Hunter River. Vegetation is predominantly tall, thick grasses. Refer to **Figure 2**.

Land to the south, downstream of the site is SEPP14 and RAMSAR wetlands. The RAMSAR boundary, adjoining the south eastern corner of the site, is an existing boundary determined by RAMSAR. Refer to **Figure 1**.

The legal points of discharge for Stage 1 are existing open channel farm drains. One farm drain is located in the south east corner of the site and the second farm drain closer to the middle of the site. These open channels flow generally south to the north-south drain which flows through the SEPP14 and RAMSAR wetlands and then into the Hunter River. Refer to **Figure 2**.

3.0 Development Description

WesTrac hold the franchise for Caterpillar equipment in NSW, ACT, WA & Northern China. WesTrac is one of the largest Caterpillar dealerships in the world, having been established in 1989. WesTrac's core business is to supply new and used Caterpillar machinery, servicing the construction, mining and forestry industries as well as local government, quarry, rental on highway trucks and marine markets. WesTrac employs more than 2000 people across Australia.

The WesTrac facility at Tomago is the NSW/ACT headquarters and employs 400 people. Refer to **Figure 3**.

4.0 Consultation

In accordance with consent requirements, consultation has been undertaken with Council and DECC (now Department of Environment and Climate Change and Water - DECCW).

Council - In a meeting with Port Stephens Council on 26 October 2009, Council engineers advised that they had no additional stormwater requirements for the development of Stage 1.

DECCW - DECCW was contacted on a number of occasions to make arrangements for consultation, however we were advised that because there were no licensing issues associated with the development, our consultation should be with NPWS. NPWS are the managers of the downstream land.

NPWS – The following consultation was held with NPWS:

- 26 October 2009 - Meeting;
- 2 November 2009 - Review of existing documentation downstream of site at NPWS office; and
- 5 November 2009 – Meeting with NPWS and BMT WBM, the consultant to NPWS.

The documents reviewed were:

- “Tomago Wetlands Final Report – Modelling Results” Issue No. 4 March 2004, issued by Patterson Britton & Partners for Department of Commerce;
- “Tomago Wetland Hydrological Study, Kooragang Nature Reserve” Technical Report 2005/28 September 2005, WC Glamore, KM Hawker and BM Miller;
- “Hunter Estuary Issues Paper Hunter Coast and Estuary Management Committee” March 2005, issued by WBM Oceanics and Parsons Brinckerhoff.
- “Review of Environmental Factors Tomago Rehabilitation Project Kooragang Nature Reserve” October 2005, NPWS.

NPWS has commenced a salt marsh rehabilitation project. This involves the remote operation of flood gates by NPWS for increased tidal ventilation, that is, salt water inundation of the Kooragang Nature Reserve downstream of the site. This is an effort to restore salt marsh and habitat. The north-south drain is the western perimeter edge of the project but also provides the outlet for stormwater (fresh water) from the upslope properties. The flood gates are at the downstream end of the north-south drain and therefore allow for tidal exchange to occur. The “Tomago Wetlands Final Report” also indicates tidal exchange from the east with outlet to Fullerton Cove and widening of existing channels to the east for increased tidal ventilation.

None of the reports provided cover the hydrology of the catchments upstream of the Kooragang Nature Reserve, the area that covers Stage 1. The “Tomago Wetlands Final Report – Modelling Results” went part way to defining a catchment however this only appeared to be desktop and was based on 1:25,000 topographic plans which are not of sufficient resolution in flat areas for determining the catchment divide.

The objective discussed with NPWS was to replicate existing hydrological conditions as closely as possible and minimise surface water/fresh water discharge to the south from Stage 1.

In summary, the key matters raised from consultation with NPWS and the consultant BMT WBM were attention to:

- Maintaining the existing flow regime;
- Design of constructed wetland outlet to avoid increased overflow of fresh water into the rehabilitated salt marsh;
- Infiltration noted as good potential for attenuation of fresh water discharges from site; and
- Monitoring continuously sampling and flow measuring instruments to monitor discharges from the constructed wetland, with lesser emphasis on quality.

BMT WBM issued a Draft letter (Ref MEW: L.N1826.001) that was a review of the existing stormwater report on behalf of NPWS. The review is focused mainly on the previous stormwater report however there is identification of some of the ideas raised to address the requirements and NPWS objectives described above. The letter is contained in **Appendix A**.

Subsequent to the BMT WBM letter, the SWMP has been modified to meet the needs of NPWS wherever possible and address all matters raised in the BMT WBM letter. This has been maintained as the priority of the SWMP wherever there is a conflict of requirements.

We have consulted with Douglas Partners who were engaged to complete groundwater modelling of the stormwater infiltration to facilitate the amendments to the SWMP. Flexibility has been built into the SWMP for future adjustment if there is variation from the required monitoring results. Douglas Partner's report is contained in **Appendix B of the SWMP**.

The conditions for compliance on stormwater quality and quantity are objectives with the view to the protection of the Hunter Estuary Wetlands Ramsar Site, downstream of the site. The Ramsar site is designated on the basis of migratory birds using the area. Extensive consultation regarding water management has been undertaken with NPWS, the land managers for the Ramsar site as described above. The consultation has been completed to ensure that the internationally significant environmental values are maintained. Stormwater discharge from the site is to the North/South Drain which passes through the Ramsar site, hence the requirement for the stormwater quality to be maintained or improved wherever possible.

5.0 Modifications to Project Application Stormwater Plan

Modifications have been made to the SWMP that was lodged with the Project Application. These changes are a result of the Director General's Assessment Report, consultation objectives, increased investigations/knowledge of the site characteristics and the consent.

The key components to the revised SWMP are as follows:

- Significant upgrade to the capacity of the constructed wetland for stormwater storage to minimise surface water discharge from the site;
- Revised infiltration locations modelled by Douglas Partners; and
- Flexibility of the stormwater system to be adjusted as a result of site conditions and monitored results after commencement of operations.

The modifications have been represented in **Figure 4**.

The strategy to infiltrate stormwater along the northern front boundary of the WesTrac site has been deleted in the revised SWMP for two (2) reasons. The temporary ponding depth for infiltration has potential to be wetting lower depth pavement materials around the perimeter road edge of WesTrac. This is not desirable. Further investigations of the regional groundwater regime indicate that stormwater infiltrating the sands within the site discharge to the south partially as groundwater to a lower confined sand aquifer and partially as surface water over the clay layer confining the lower sand aquifer.

Outcomes from Douglas Partners modelling were that existing surface water flows passing through the site are higher than previously expected. This is because regional groundwater flows from the Tomago sand beds overflow onto the surface, as surface water at the interface of the sand dune and commencement of the clays of the floodplain. That is, there are contributing surface flows of regional groundwater from external, upstream catchments passing through the site. This is consistent with Hunter Water Corporation letter advice that regional groundwater flow direction is to the south. Refer to **Figure 5**.

The revised SWMP is based on a revised strategy to infiltrate stormwater on site and has been developed in consultation with Douglas Partners. It is proposed to construct Caisson Wells along the southern boundary of the site within the swale area. These wells are described as a vertical pipe filled with gravel which penetrates through the clay layer to the lower confined aquifer. Douglas Partners has completed groundwater modelling of this infiltration strategy to maintain existing groundwater flow regime following development of the site and explore opportunity for additional recharge via infiltration. The results are included in site water balances and proportioning of surface water and groundwater discharges. Whilst initial design will be to maintain the same proportions for mitigation of any impacts, flexibility has been built into the system for future adjustment as monitoring results become available. Refer to **Figure 5**.

The constructed wetland downstream of the south eastern corner of the site has been significantly increased in size and modified to meet NPWS objectives. The surface area of this

constructed wetland was indicated to be 1.1 hectares for WesTrac and 1.9 hectares following some contribution of stormwater from an adjacent future industrial development stage. To take a conservative approach, the WesTrac facility will utilise the full dedicated area of the constructed wetland at 1.9 hectares. The management of stormwater discharge from the future industrial stage will be assessed under separate application and use of the constructed wetland or otherwise will be subject to the monitoring results of the WesTrac, Stage 1 operations. The increase in constructed wetland surface area provides significantly increased storage, evaporation area and also water quality treatment. Refer to **Figure 4**.

The outlet configuration of the constructed wetland has been modified with a strategy to further reduce the stormwater discharge from site. It is proposed to set the water level control structure with low flow discharge and spillway flows during major storms. This is to store the runoff from a much larger storm event within the constructed wetland. Larger quantities of surface water discharge from the constructed wetland will only occur during a large storm for a short period, when there will already be saturation of the downstream system with freshwater. This is a further strategy derived from the consultation with NPWS. Drawdown of the constructed wetland will occur via the low flow pipes from the water level control structure at the outlet of the constructed wetland and evaporation. Retention times have been modelled in the order of 48 hours.

Bioretention trenches are proposed along the perimeter swale drainage of the southern boundary. This is to provide treatment of stormwater runoff resulting in improved water quality of prior to infiltration through the Caisson Wells. All runoff will pass through the bioretention trenches prior to entering the wells. Refer to **Section 8.2**.

The revisions to the stormwater management system have been focused around the needs of NPWS and providing a flexible system with adjustment for fine tuning of the stormwater strategy as a result of monitoring during operations.

The upgrade of the constructed wetland area from 1.1 hectares to 1.9 hectares is significant in meeting the NPWS objectives of minimising surface water discharge. The constructed wetland stage/storage discharge relationship and characteristics used for all modelling is shown below in **Table 4**.

Table 4 – Stage and Storage Characteristics for Constructed Wetland

Stage (mAHD)	Storage (m ³)	Notes
0.3 – 0.8	6,580	Permanent Water Level – 0.8mAHD, approximately 25mm runoff depth from WesTrac site
0.9	9,580	
1.0	12,730	
1.1	16,200	Starting level of extended detention depth within perimeter drainage of WesTrac site
1.2	19,990	
1.3	24,060	Initial setting for spillway level, 17,480m ³ Extended detention storage is approximately 66mm runoff depth from WesTrac site
1.4	28,360	
1.5	32,890	
1.6	38,150	Level to which spillway can be raised without compromise of freeboard. Extended detention storage is approximately 120mm runoff depth from WesTrac site
1.7	43,600	
1.8	49,250	
1.9	55,190	Level of peak storage, top of berm surround to constructed wetland

From Table 6.3a of “*Managing Urban Stormwater Soils and Construction*” (Blue Book) 4th Edition, Volume 1, March 2004 produced by Landcom, 95th percentile 5 day rainfall depth for Newcastle is 76.7mm. Following the factoring in of standard initial and continuing losses for rainfall conversion to runoff, the constructed wetland extended detention storage is likely to exceed the storage of 95th percentile 5 day rainfall depth. That is, up to the level of 1.3mAHD, the constructed wetland will have storage for 95% of 5 day storm events, with low flow discharge occurring and no discharge over the spillway.

Comparison can be made between the significance storage of the constructed wetland and other regulatory departmental requirements.

The constructed wetland storage exceeds standard DECCW environmental protection licensing storage requirements for sediment dams on landfill sites. The standard sizing of sediment dams is storage for the runoff from 90th percentile 5 day rainfall events. Similarly, “*Managing Urban Stormwater: Mines and Quarries – Consultation Draft 2007*” produced by DECC requires the 90th percentile rainfall event to be used for basin sizing for mines and quarries. For Newcastle, the 2 day depth and 5 day depth is 31.8mm and 51.8mm respectively. This sizing of sediment basins is also for highly disturbed areas with high levels of sediment entrainment In stormwater runoff that requires settling before discharge. By comparison, the WesTrac site will be finished with

hardstand and landscaping, although a conservative approach to sizing of the constructed wetland has been adopted.

Beyond the initial system setting for storage up to the proposed spillway level of 1.3mAHD, there is flexibility in the spillway configuration to upgrade storage for extended detention depth of 120mm runoff from the WesTrac site at the spillway level of 1.6mAHD, if required. This may also be the mechanism for connection of the stormwater from future industrial stages, subject to monitoring and modelling predicted outcomes.

6.0 Site Water Balance

6.1 Objectives

Following the consultation with NPWS, it is understood that maintaining existing regime and minimising the quantity of stormwater discharge is the key consideration. BMT WBM, the consultant to NPWS, also reviewed the site water balance from the Stage 1 SWMP sent to Agencies for consultation in detail – their letter is contained in **Appendix A**. The outcome of the consultation was that modifications were made to minimise the surface water discharge to the south as described in **Section 5.0**.

The objectives of the site water balance are as follows:

- Maximise water reuse on site;
- Identify the sources and security of water supply to the site; and
- On a regional context, minimise the opportunity for fresh water discharge downstream.

6.2 Regional Context to Water Balance

In order to meet these objectives, Douglas Partners were engaged to complete groundwater modelling to more accurately establish the existing surface and subsurface flow regime through the site. Douglas Partners indicate that regional groundwater flows passing through the site during an average rainfall year are estimated to be in the range of 70-150ML per year. This quantity passes through the existing site as overflow from the Tomago sandbeds. Hence recharge of the existing sand area will only result in flows passing through the site in a southerly direction.

Since the site is downslope of both the surrounds and groundwater elevations, there are no gravitational alternatives for stormwater discharge other than discharge to the north-south drain south of the site.

As described in **Section 5.0**, Douglas Partners investigated relocation of the infiltration to the southern boundary via a series of Caisson Wells. Douglas Partners has used a recharge rate of 50ML per year from BMT WBM estimates as the contribution rate of the existing site to the regional groundwater flow. The groundwater regime can be maintained closely equivalent to the existing regime of 50ML per year infiltration via the Caisson Wells. Douglas Partners also explored the opportunity of an elevated recharge rate of 110ML per year with groundwater modelling. Whilst there are advantages to increasing infiltration rates, it was determined that the initial system setting for stormwater should be to initially maintain the existing groundwater flow regime as the solution to minimise risk of potential impact.

6.3 Operations Water Balance Parameters and Characteristics

The sources and security of supply for the development of the WesTrac facility are as follows:

- Lead in water main from Hunter Water Corporation's regional water supply system (potable town water supply);
- A 2ML rainwater tank storage will be provided on site for stormwater capture and reuses.

The nearest Bureau of Meteorology (BOM) station to the WesTrac facility is Williamtown (Station Number 61078). This station is approximately 7-8km from the WesTrac site. Long term statistics of rainfall are as follows:

- Driest annual rainfall year recorded was approximately 541mm – 1980.
- Average annual rainfall is approximately 1120 mm per year.
- Wettest annual rainfall year recorded was approximately 1739mm – 1990.

Average Evapotranspiration is approximately 1360mm per year for the area.

Approximately half of the site will be cut to fill operations with some imported fill as necessary to mound the site. Fall to the edges is predominantly to the north and south. The hardstand area proposed will be impervious. Roof areas will drain to a large rainwater tank storage within the site. End discharge will be to a large constructed wetland to the south east of the site.

The subcatchment characteristics are shown below in **Table 5**.

Table 5 – WesTrac Subcatchments

Catchment	Area (ha)
Roof	4.0
Hardstand Area	13.3
Landscaped area, Perimeter Swale Drainage	5.7
Constructed Wetland	1.9
Total	24.9

All roof water is to be captured with the rainwater tank system. The tank is most likely to be associated with the spine/pedestrian access centrally within the site.

There are a number of uses for this harvested water including:

- Toilet flushing;
- Washpad water use – WesTrac and B/Con;
- Dyno/Transmission Testing;
- Display Pond top up; and
- Landscape irrigation.

The potable town water uses will be canteen and showers. The potable town water uses will also be backup to the rainwater tank uses described above. These uses are shown below in **Table 6**.

Table 6 – WesTrac Operational Water Uses

Item	Quantity (kL/day)	Source
Canteen, Showers	6.7	Town Water
Toilet Flushing	10.5	Roof water/Rainwater Tank
Washpad – WesTrac	5	Roof water/ Rainwater Tank/Hardstand Area
Washpad – B/Con	5	Roof water/ Rainwater Tank/Hardstand Area
Dyno/Transmission Testing	12*	Roof water/Rainwater Tank
Total	39.2	

*-This is an allowance for 2 Dynos, extrapolated on current water usage rates for the Dyno at Mt Thorley.

In addition to these uses, water from the rainwater tank system will be used for the top up of the Display Pond and irrigation of landscaped areas. The quantity of these uses is however, dependent on rainfall and evaporation and has been related in the water balance model accordingly. The Display Pond will be maintained at 80% full. The landscaped areas will be irrigated at a rate of 0.5mm/m² whenever rainfall doesn't exceed 2mm per day. This is a large quantity which may be reduced by WesTrac for landscaped areas not in full view.

The reuse of rainwater tank water has been maximised and potable town water minimised, there are no other practical on site uses during operation available. Maximising reuse is in accordance with “*Water Sensitive Urban Design Solutions for Catchments above Wetlands*” by Hunter & Central Coast Regional Environmental Management Strategy (HCCREMS). Operations will be over a 7 day working week, resulting in **rainwater tank use of approximately 43KL/day**. Previous water balance modelling indicates efficiencies of 92.7% for rainwater tank water use.

The network of rainwater uses is shown in **Figure 6**.

6.4 Summary of Results

A basic summary of the site water balance for an average annual rainfall year, the following site characteristics (where known) and assumptions were made:

- Site Area – 24.9ha (23ha development site area and 1.9ha constructed wetland area)
- Impervious Runoff – 90%
- Pervious Runoff from clays – 50% due to saturation, farm drains
- Pervious Runoff from import fill – 25% due to topsoil and granular fill material

The site water balance for the existing site, for an average rainfall year of approximately 1110mm, is as follows:

- Rainfall – 276ML
- Surface runoff and infiltration to clay area – 93ML
- Dunal formation infiltration – 50ML*
- Total surface runoff and infiltration/groundwater recharge – 143ML
- Evapotranspiration – 149ML

* - note that the dunal formation infiltration may not be exclusive to groundwater recharge, contributing to surface flows either close to or downstream of the site.

The site water balance for the post development site, for an average rainfall year of approximately 1110mm, is as follows:

- Rainfall – 276ML
- Surface runoff (at source) – 189ML
- Runoff uses
 - Operations uses (Table 6 including Landscape and Display Pond) 15.5ML
 - Constructed Wetland Evapotranspiration – 26ML
- Total surface runoff and infiltration – 147.5
- Dunal formation infiltration – 50ML*
- Total surface runoff and infiltration/groundwater recharge – 197.5ML
- Evapotranspiration – 78.5ML

Comparison of the site water balance indicates an additional fresh water discharge of 54.5ML per year (197.5 – 143) post development.

The constructed wetland outlet configuration has been designed for the controlled release of this additional freshwater volume. In consultation with NPWS' consultant, NPWS remotely opens the flood gates for the draining of freshwater from the wetland immediately following large rainfall events. Timing of the opening is subject to tidal levels in the Hunter River. The design of the constructed wetland is to also be discharging stormwater at this time. It is envisaged that this the most opportune time for least impact of the additional fresh water

discharge when the downstream area is saturated, also noting that there is significant storage for retention of runoff volumes from minor storms.

Peak flows from the low flow outlet control structure of the constructed wetland, considering a 48 hour retention time, is in the order of $0.01-0.1\text{m}^3/\text{s}$ (max) through a 250mm outlet pipe. Existing peak flows from and through the site from regional sources are orders of magnitude greater than this discharge by comparison and like for like, are compared to spillway flows from the constructed wetland following development (refer to **Section 8.3**). Modelling results shown in **Tables 15-19** demonstrate significant peak flow attenuation of the post development flows by comparison to existing peak flows as a result of the significant storage capacity provided. Flexibility options are described in **Section 6.7**.

Peak flows will not be exceeded, however the additional fresh water volume of surface water discharge from the constructed wetland will be discharged over 48 hour period (maximum) following a large storm.

Full details of the water management, monitoring and reporting are contained in **Section 9.0**.

6.5 Contingency/Flexibility Options

There are several contingency and adjustment options available in the SWMP to allow flexibility and adaptation of the system to monitored results.

The adjustable controls are located as shown in **Table 7** below.

Table 7 – Flexibility Option Controls

Item	Description of Adjustment*	Description of Location	Adjustment Range/Function	Initial Setting
Weir adjustment (regional infiltration)	Spillway, Boards or earth	Eastern boundary in perimeter swale drainage	1.5-1.7mAHD, control of regional groundwater flows through site	1.5mAHD (unrestricted)
Infiltration adjustment (site infiltration)	Spillway, Boards or earth	Southern boundary perimeter swale drainage, close to constructed wetland	1-1.3mAHD, increase discharge through Caisson Wells	1mAHD (unrestricted)
Constructed Wetland outlet – low flows	Water Level Control Structure – Screw caps to pipe outlets	South eastern corner of constructed wetland	0.8-1mAHD, adjustment to permanent water level	0.8mAHD
Constructed Wetland outlet – high flows	Spillway, boards or earth	South eastern corner of constructed wetland	1-1.6mAHD, adjustment to extended detention storage level	1.3mAHD

* - subject to detailed design

The initial settings shown in **Table 7** are the basis of this reporting and all modelling completed. These values represent the best estimate of the required controls to meet all objectives. Modelling will be required prior to any adjustment and following input of the monitoring data for cause and effect. Refer to **Section 9.0**.

Emphasis has been placed on the revised SWMP meeting the NPWS objectives and providing a system that is flexible for future adjustment and fine tuning as a result of the monitoring outcomes. Beyond the designed system flexibility shown in **Table 7**, there are further

contingency opportunities that have not been fully investigated, but may become available to adjust the system in the future if required. The most practical of these is working with NPWS to determine appropriate times of discharge of stormwater from the site (ie when flood gates are opened by NPWS).

Other unexplored alternatives include salt dosing of stormwater prior to discharge from the wetland, drainage channel for direct discharge to the Hunter River through the future industrial lands and potentially pumped stormwater supply back upslope to Hunter Water Corporation's Tomago Sandbeds for treatment and their retailing as potable water. None of these contingency opportunities have been explored in any detail or necessary at this stage.

7.0 Erosion and Sediment Control Plan

Erosion and sediment controls, described in a Soil and Water Management Plan (SWMP) are necessary during construction for the protection of receiving waters downstream. Erosion and sediment control measures are temporary, and are required until such time that the building and construction areas are landscaped, revegetated and sealed.

Throughout multiple stages of construction soil generating activities with erosion potential will arise. As the site will require cut to fill and further preload to induce consolidation of the underlying clays, measures will be taken to ensure sediment runoff requirements are met. The time period expected for fill preload may exceed 30 days and if so would be covered with mulch or temporary vegetation. The same conditions will be met relative to top soil stockpiling. During construction machinery movements over the site will create overlying potential sediments, this will be controlled on ground via proprietary sediment fencing and eliminated being airborne via standard water cart usage during earthworks. Mitigation measures for erosion and sediment control will be described further in this section.

Initially, the constructed wetland area will be established as a sediment dam. In its location, the sediment dam will be the final control treatment since further intermediate dams will be established along the southern boundary. Sediment fencing will also be installed along the southern boundary.

Although a significant quantity of the bulk earthworks to be completed will be cut to fill of the dunal sands on site, Type C soils, there is potential for Type F soils to be disturbed during construction. As a result the sediment basin has been designed for settlement of Type F soils. The volumetric coefficient of runoff has also been conservatively estimated, since the majority of soils to be disturbed will be sand.

To be conservative, a higher criteria level of protection has been adopted for the design sizing of the sediment basin(s), reflecting the sensitivity of the receiving waters downstream. "Managing Urban Stormwater: Mines and Quarries – Consultation Draft 2007" produced by DECC, was referenced due to the scale of the site works. The 90th percentile rainfall event is the standard for mines and quarries. It is also described that 2-5 day rainfall events are suitable criteria for well managed sites in which prompt action can be guaranteed. At this site the 95th percentile, 5 day rainfall event has been selected, which is approximately 3 times the storage volume of that generated by using the 75th percentile, 5 day rainfall event typically used for development sites. This gives the basin an increased capacity, capturing runoff from a greater number of storm events. This minimises the potential risk of sediment laden water leaving the site and discharging to the wetlands downstream during construction.

An overall sediment basin allowing for full site disturbance, sized in accordance with "Managing Urban Stormwater Soils and Construction" (Blue Book) 4th Edition, Volume 1, March 2004 produced by Landcom, has been sized to be approximately 9,835m³, refer to **Appendix C**. This sediment basin quantity is apportioned between the sediment basin at the constructed wetland site and a number of smaller intermediate dams for greater control of runoff during construction. Further details of the sediment dams are being completed for detailed design, in

conjunction with the bulk earthworks strategy. Refer to **Figures 7 and 8**.

7.1 Erosion and Sediment Control

Erosion and sediment control measures to be implemented during construction include:

- 1) Disturbance only of areas to be immediately worked on and regeneration of dust and erosion free surfaces – seeding of important fill, preload stockpiles, landscaping, concrete, bitumen sealing as soon as practical thereafter.
- 2) Provision of and continued maintenance of sediment fencing to low perimeter locations.
- 3) Provision of mesh and gravel or geotextile inlet filters.
- 4) Contract specifications requiring stabilised site access, low flow earth flow earth banks and wind erosion screens.
- 5) A construction programme that provides for the sediment basin to be constructed at the outset with all site runoff, where practical, piped or channelled to this basin for primary treatment/settlement before leaving the site via a mesh supported geotextile filter/riser before discharging to the wetlands. Discharge is subject to limits of Total Suspended Solids of 50mg/L. Refer to **Figure 8**.
- 6) Contract specifications requiring regular maintenance of all erosion and sediment control structures and devices for the full contract and maintenance period.

7.2 Land Disturbance Conditions

Where practicable the soil erosion hazard shall be kept as low as possible. Limitations to access are to be in accordance with **Table 8**.

Table 8 – Land Use Limitations

Land Use	Limitation
Access Areas	Access is to be limited to the designated all weather roads.
Truck Wash Down Bay	Any truck exiting out of the site shall be thoroughly cleaned and limit the exportation of clay and sediment on public roads.
Remaining Lands	Entry is prohibited to remaining land.

7.3 Construction Sequence

Works shall be undertaken in the following sequence prior to the commencement of bulk earthworks:

- 1) Install sediment fencing and cut drains to meet the requirements of the SWMP. Waste collection bins shall be installed adjacent to site office.
- 2) Construct stabilised site access in location nominated by the Contractor and in accordance with Port Stephens Council's requirements.
- 3) Construct sediment basins for disturbed areas in accordance with the rate per hectare provided in the SWMP (**Section 7.0**). Install risers and two pegs in the floor of the basin and have them marked to show the top of the sediment storage zone. Ensure the basin is cleared of sediment once the design capacity is reached.
- 4) Redirect clean water around the construction site.
- 5) Install sediment control protection measures at all natural and man-made drainage structures. Maintain until all the disturbed areas are stabilised.
- 6) Clear and strip the work areas in accordance with the geotechnical advice.
- 7) Any disturbed areas, other than lot grading areas, shall immediately be covered with site topsoil within 7 days of clearing. Lot re-graded shall be covered with bitumen emulsion as specified.
- 8) Apply permanent stabilisation to site (landscaping).

7.4 Sediment Control Conditions

- 1) Proprietary sediment fencing shall be installed by the Contractor in accordance with their approved SWMP and elsewhere at the discretion of the site superintendent to contain sediment fractions as near as possible to their source.
- 2) Sediment removed from any trapping device shall be relocated where further pollution to downslope lands and waterways cannot occur.
- 3) Stockpiles shall be located by the Contractor in accordance with their approved SWMP and elsewhere at the discretion of the site superintendent. Where stockpiles are to be in place longer than 30 days they shall be stabilised by covering with mulch or with temporary vegetation.
- 4) Water shall be prevented from entering the permanent drainage system unless it is sediment free. Drainage pits are to be protected in accordance with the Contractor's approved SWMP.

- 5) Temporary sediment traps at pits shall be retained until after lands they are protecting are completely rehabilitated.
- 6) Dust suppression will be required for the control of airborne particles during construction. This will be via standard water cart usage during earthworks and pavement construction of the hardstand areas.

7.5 Site Maintenance Requirements

- 1) Waste bins are to be provided for all construction refuse. They are to be emptied at least weekly and refuse is to be disposed in accordance with the site manager's recommendations.
- 2) The site manager shall inspect the site at least weekly and shall:
 - (a) Ensure that all drains are operating effectively and shall make any necessary repairs;
 - (b) Remove any spilled material from area subject to runoff or concentrated flow;
 - (c) Remove trapped sediment where the capacity of the trapping device falls below 60%;
 - (d) Inspect the sediment basins after each rainfall event and/or weekly. Ensure that all sediment is removed once the sediment storage zone is full (refer to pegs installed in basins in accordance with the SWMP). Ensure that outlet and emergency spillway works are maintained in a fully operational condition at all times;
 - (e) Ensure rehabilitated lands have effectively reduced the erosion hazard and initiate upgrading or repair as appropriate;
 - (f) Construct additional erosion or sediment control works as may be appropriate to ensure the protection of downslope lands and waterways;
 - (g) Maintain erosion and sediment control measures in a fully functioning condition at all times until the site is rehabilitated;
 - (h) Ensure that the revegetation scheme is adhered to and that the all grass covers are kept healthy, including watering and mowing;
 - (i) Remove temporary soil conservation structures as the last activity in the rehabilitation program.

8.0 Stormwater Management Scheme

8.1 Strategy

From the consultation with NPWS as described in **Section 4.0**, the existing hydrological conditions are being replicated as closely as possible, with the additional objective of minimising surface water discharge. All roof water will discharge to rainwater tank for reuse. The rainwater tank size is 2ML. The site is graded in a mounded shape with a crest at the spine corridor and fall predominantly to the north and south. Overflows from the rainwater tank will be via perimeter open channel swale drainage to the swale along the southern boundary. Grated pits and piped drainage will collect surface water from hardstand areas. The piped drainage and site grading of hardstand areas will be to the perimeter drainage of open channel swales. The swales are drained by Caisson Wells for infiltration along the southern boundary minimising surface water discharge. Overflows ultimately discharge to the constructed wetland of surface area approximately 1.9 hectares located to the south eastern corner of the site. The constructed wetland has significant permanent storage capacity of 6,580m³ and temporary extended detention storage of 17,480m³ (based on initial settings of 0.8mAHD for low flow and 1.3mAHD for the spillway outlet). This strategy is optimised to achieve the NPWS objectives and meet the consent requirements.

As described in the Site Water Balance in **Section 6.0**, the strategy is based on minimising surface water discharge from the constructed wetland. A high storage capture volume has been used to contain stormwater runoff with only low flows discharging from the majority of design storm simulations. Discharges will only occur in larger storms or very long duration smaller storms, at which time there is certainty that the downstream receiving areas are also inundated with fresh water. Discharges will be controlled with a 250mm pipe low flow outlet at 0.8mAHD and 10m wide spillway at a level of 1.3mAHD. Flexibility has been built into the system as shown in Table 7 for the water level control structure, spillway and other controls around the site. Drawdown of the constructed wetland between storms will be based on 48hours retention time and then evaporation action on the permanent water storage.

This strategy is effective in addressing wetting and drying cycles for the wetlands downstream.

8.2 Water Quality

As described in **Section 8.1**, surface water discharge from the site has been limited due to the significant storage capacity of the constructed wetland.

The primary water quality control on site will be for the excess water from the Washpads. The purpose of these washing facilities is to clean heavy mechanical equipment prior to workshop activities. WesTrac has standardised control over these facilities country wide at its existing operations. This issue is addressed in **Section 8.2.1**.

The remainder of the site is more general water quality treatment of finer dust and sediment

entrained in runoff after collecting on the hardstand areas between rainfall events. This issue is addressed in **Section 8.2.2** with MUSIC modelling.

8.2.1 Washpads

There are two (2) washpads, WesTrac and B/Con, proposed on site for the purpose of cleaning heavy mechanical equipment prior to workshop activities. The process involves using a biodegradable detergent which releases free oil after addition of an emulsion breaker for efficient oil separation and collection, together with a detergent stripping stage using a foam fractionator. The resultant treated water is recycled through a filtration and sterilisation stage. A portion of treated water is removed from the circuit and sent for final treatment to the site sewage treatment plant.

Water for washpad operations is derived from three (3) sources:

- rainwater harvesting;
- town water; and
- recycled water.

All washpad solids are collected in a sump with capacity to be operated for a number of months prior to solids removal. Accumulated solids from the sump will be disposed of to NSW Class1 landfill by a licensed waste disposal contractor.

The resultant wastewater is pumped via a floating drawoff to a settling tank after dosing with a primary flocculant. The settled solids are returned to the solids sump for final disposal. The primary flocculant dose breaks all emulsions and presents free oil and wastewater to the skid mounted oil / water separator. Oil/Water separation is achieved using a heavy duty coalescing plate separator with waste oil being pumped to a double skinned storage tank before final disposal using a licensed contractor.

Wastewater produced by the separator is further treated by a foam fractionator (surfactant removal), with the surfactant waste collected and disposed of by a licensed contractor. The treated washpad wastewater is recycled after surfactant removal. Recycle water undergoes further treatment using chlorination and sand filtration. The recycled water feeds a low pressure wash unit with inline UV sterilisation. The spent wash water drains to the solids sump at the start of processing for reuse.

There is also a low volume high pressure wash unit proposed for the washpad which uses rainwater and/or town water. This water also drains to the solids sump after use.

The washing process utilises a number of chemicals most of which are classified as non hazardous. These include the following:

- Surfactants;
- Degreasers;
- Primary Alum Flocculant;
- Sodium Hypochlorite; and
- Hydrochloric Acid for pH control.

The main chemicals in use on the washpad will be for cleaning purposes and comprise the following:

- Emulsion Breaker Primary Flocculent /Polyelectrolyte based on poly aluminium chloride; and
- Non solvent alkaline cleaners and degreasers.

These products are designed to remove a broad spectrum of soils, grease and grime.

All the chemicals in use on the washpad have been selected by WesTrac for biodegradability and environmental acceptability. WesTrac has a standard policy on chemical purchase as part of its country wide environmental policy. The chemical selection policy takes account of the need to replace solvent based cleaners and degreasers such as Kerosene.

The chemical storage and use areas are bunded and the following safety equipment will be deployed in the washpad area:

- Eye Wash and Shower
- Fire Extinguisher
- First Aid Box
- Safety Signage

In addition to chemical standardisation, WesTrac has carefully selected a preferred washpad equipment manufacturer and installer who provides operation and maintenance backup on an all-round basis. The contractor/supplier is approved by Hunter Water for this type of process.

8.2.2 Water Quality Modelling

MUSIC modelling has been undertaken of the water quality for two (2) simulations, the treatment before discharge through the Caisson Wells and treatment before discharge from the low flow outlet.

The strategy for water quality improvement is a water sensitive urban design solution using a treatment train process. Roof water will enter the rainwater tank and then overflows to the perimeter drainage along the southern boundary. Drainage from the remainder of the site, both landscaped and hardstand areas will be to the perimeter drainage with overflows to the constructed wetland. All piped drainage runoff from the hardstand areas will pass through Gross Pollutant Traps. All runoff will pass through the bioretention trenches located in the perimeter swale drainage prior to discharge through the Caisson Wells. The treatment properties of the Caisson Wells have not been included in the model. The swale drainage surface, some 700m in length for drainage from the northern perimeter drainage has not been modelled. A conservative approach to modelling has been undertaken due to the potential model limitations and the requirement to monitor groundwater.

Similarly, low flow discharge from the constructed wetland area has been conservatively estimated.

In accordance with the Director General's assessment, "Managing urban stormwater: environmental targets" (Consultation Draft 2007) produced by DECC has been used as the target objective of stormwater for pollutant removal. The DECC targets are as follows:

- *90% reduction in the average annual gross pollutant load*
- *85% reduction of average annual total suspended solids load;*
- *65% reduction in the average annual total phosphorus load;*
- *45% reduction in the average annual total nitrogen load.*

The main source of pollutants is the hardstand pavement catchment area surrounds to the buildings. Whilst WesTrac operations are clean, the dust and sediment accumulation on the pavement surface between rainfall events is the target of stormwater treatment. Runoff from this catchment discharges mostly to piped drainage and gross pollutant trap prior to a swale which treats and conveys the runoff to a constructed wetland south of the south eastern corner of the site.

A proportion of the overflows from the rainwater tank system will also enter this catchment to the constructed wetland, however, considering that rainwater tank storage is large and that we are using MUSIC to assess water quality, this flow, in times of higher rainfall, will not be considered. This is because water quality calculations are focused on regular runoff from smaller storm events. This runoff contains the majority of pollutants collected on the surface between storm events. Note that this stream of rainwater tank overflow was included for the overall runoff volumes to the wetlands downstream.

The following key parameters, generally in accordance with MUSIC user manual, were adopted:

- Rainfall/Evapotranspiration – 6min rainfall data for Williamtown BOM station was used for the simulation. The data was collected from 2004, closely equivalent to the average rainfall for Williamtown – 1099mm by comparison to 1120mm being the long term average. Evapotranspiration in the model is 1347mm, closely equivalent to 1360mm also sourced from the Bureau of Meteorology.
- The “Roof Area” used in the MUSIC model is 4 hectares as 100% impervious. The “Hardstand & Pervious Site Area” used in the model is 19 hectares at 70% impervious. Refer to **Figures 6 and 9**.
- Default parameters have been used for pollutant generation parameters from the hardstand areas. Export of the pollutants was simulated in “stochastic generated” mode.
- Treatment node parameters for the model simulations consist of a gross pollutant trap, bioretention trench and rainwater tank storage and reuse for the roof area prior to discharge through the Caisson Wells. The bioretention trench area was assumed to be lined in accordance with Douglas Partners requirements. The filter area is 1860m² and depth of 0.3m. Based on a finished surface invert level of the perimeter swale drainage of 1.1mAHD, connection will be made via subsoil drainage to the Caisson Wells at 0.8m AHD. The walls of the well will extend to a level of 1.3mAHD to ensure that no flows enter the well without passing through the bioretention trench system. Refer to **Figure 10** for a schematic of this configuration.

A comparison of the pollutant modelling simulations for pre development and post development with controls (ie treatment train), is shown below in **Table 9**.

Table 9 – Water Quality Modelling Results from MUSIC – Discharge to Caisson Wells

Pollutant	Post Development (no controls)	Post Development (with controls)	Treatment Train Effectiveness (%)
Total Suspended Solids (kg/year)	57,000	2,570	95.5
Total Phosphorus (kg/year)	80.4	16.8	79.1
Total Nitrogen (kg/year)	514	280	45.5

Table 10 – Water Quality Modelling Results from MUSIC – Discharge from Constructed Wetland

Pollutant	Post Development (no controls)	Post Development (with controls)	Treatment Train Effectiveness (%)
Total Suspended Solids (kg/year)	57,000	716	98.8
Total Phosphorus (kg/year)	80.4	7.06	91.6
Total Nitrogen (kg/year)	514	132	74.0

The modelling results in **Table 9** and **10** indicate that the post development simulation with mitigation controls in place, meets the environmental performance targets of the Stormwater Report – Volume 2, Appendix F of the EA and DECC target objectives for TSS, TP and TN of 85%, 65% and 45% respectively prior to discharge to the Caisson Wells or low flow discharge from the constructed wetland. 100% of Gross Pollutants will be removed exceeding the requirement for 90% removal. WesTrac is a clean operation, so it is anticipated that the majority of the Gross Pollutants will be heavy sediment. Contamination of runoff may also be the entrainment of oil drips in runoff from the hardstand areas.

Groundwater monitoring is proposed along the southern boundary of the site, refer to Douglas Partners report, reference in **Section 9.0**.

8.3 Peak Discharges

In accordance with condition 12 (c) of the consent, demonstration is required “that post development flows will not exceed predevelopment flows for a range of ARI from 1 year up to and including the 100 year ARI”. These results are for peak flows from the constructed wetland only. Water balance information is contained in **Section 6.0**. Water quality information is contained in **Section 8.2**.

The hydrological analyses for this study adopted the flood routing model XP-RAFTS (RAFTS). Parameters of catchment area, imperviousness, catchment slope and rainfall losses were used to simulate the catchment response to storm events, generating hydrographs for the estimate of peak discharge. The site was subdivided into a series of subcatchments for the pre development and proposed development simulations.

8.3.1 Rainfall Data

Design rainfall Intensity-Frequency-Duration (IFD) for the site was obtained using methods setout in Australian Rainfall and Runoff (ARR) 1987, which were checked against the published data in Port Stephens Council – “Subdivision Code”. A summary of the rainfall intensities used in this study are shown in **Table 11**. Rainfall temporal patterns for the design storms are taken from ARR.

Table 11 – Rainfall Intensities for Tomago

Storm Duration (min)	Rainfall Intensity (mm/hr)						
	Recurrence Interval						
	1	2	5	10	20	50	100
5	82	106	136	154	177	208	231
10	63	81	104	118	136	159	177
15	52	68	87	98	114	133	148
20	45.7	59	76	86	99	116	129
25	40.8	53	68	77	88	104	116
30	37.1	47.9	62	70	80	94	105
45	29.7	38.4	49.5	56	65	76	84
60	25.2	32.6	42	47.5	55	64	72
90	19.8	25.5	33	37.3	43.1	51	56
120	16.6	21.4	27.6	31.3	36.1	42.5	47.4
180	12.9	16.6	21.5	24.4	28.2	33.2	37
270	9.98	12.9	16.7	19	21.9	25.8	28.8
360	8.34	10.8	14	15.9	18.4	21.6	24.2
540	6.48	8.38	10.9	12.4	14.3	16.9	18.8
720	5.42	7.01	9.12	10.4	12	14.2	15.8

8.3.2 Calibration

RAFTS is most accurate for the prediction of peak flow estimation when calibrated to historical rainfall and stream flow data for the catchment being investigated. Since there is no historical stream flow data available for this catchment, the model was calibrated to the Probabilistic Rational Method (PRM). The PRM is widely accepted as a reliable estimate of peak discharge rates, in lieu of actual data. The Storage Coefficient Multiplication Factor (Bx) was adjusted to 0.95 in the RAFTS model and achieved close correlation with the PRM peak discharge for the site.

8.3.3 RAFTS Modelling Parameters

Mannings 'n' is the subcatchment roughness factor; this value is adjusted to represent the different response of rural and urbanised catchments, impervious and pervious surfaces. The adopted 'n' values are shown below in **Table 12**.

Table 12 – RAFTS Mannings 'n' Values

Parameter	Catchment Condition	Value
Mannings 'n'	Impervious	0.015
	Pervious	0.035

RAFTS modelling was undertaken using the standard initial and continuing loss infiltration parameters. The existing, pre development site has two main soil material types, clay and sand. These types were represented with different initial and continuing loss parameters, modified to more closely match the site characteristics of waterlogging and saturation. The post development simulation was further differentiated by adopting more typical initial and continuing loss parameters due to the extent of imported fill material over the top of the clays. The initial and continuing losses adopted were as follows:

- “Sand” Pervious Catchment – Dunal formation area, approximately 10 hectares
 - Initial Loss 15.0mm
 - Continuing Loss 5.0mm/hr
- “Clay” Pervious Catchment – Floodplain & constructed wetland area, approximately 15 hectares
 - Initial Loss 5.0mm
 - Continuing Loss 1.0mm/hr
- “Site Fill” Pervious Catchment – Post Development filled area over floodplain
 - Initial Loss 10.0mm
 - Continuing Loss 3.0mm/hr
- Impervious Catchment – Hardstand area
 - Initial Loss 1.5mm
 - Continuing Loss 0.0mm/hr

Channel routing effects were modelled by RAFTS using a simple lag time approach. The lag times were estimated by velocity derived from the length and slope of channels and perimeter drainage. Lag times used in the RAFTS model were as follows:

- North of hardstand area – 10mins
- South of hardstand area – 6.7mins
- Roof areas – 5mins
- Constructed Wetland – 0mins

Table 13 presents the estimated lag times adopted for the existing predevelopment and post development simulations.

Table 13 – Subcatchment Area Characteristics

Pre Development Catchment Area (ha)	Post Development Catchment Area (ha)
North – Sand, 10ha	North – Sand, 2.52ha North – impervious, 5.4ha
South – Clay, 13ha	South – Site Fill, 3.6ha South – Impervious, 7.4ha
	Roof – Impervious, 4.08ha
Constructed Wetland – Clay, 2.05ha	Constructed Wetland Area – Clay, 2.05ha
25.05ha	25.05ha

The roof areas drain to the 2ML rainwater tank. To be conservative, the tank was assumed to be 100% full prior to the storm event occurring, for all RAFTS modelling simulations.

8.3.3 RAFTS Peak Discharge Estimates

Peak discharge from the WesTrac Stage 1 site was estimated for the predevelopment and post development simulations. Simulations are based on the constructed wetland having an outlet, spillway crest level of 1.3mAHD for discharge off site. The permanent water level stage assumed was full at 0.8mAHD, when peak flow attenuation storage commences. This level is the invert level for infiltration through the Caisson wells. This is conservative, since there is likely to be evaporative drawdown from the permanent water level prior to the next storm event occurring. **Table 14** indicates the detention storage used for peak flow attenuation, taken from **Table 4**.

**Table 14 – Stage and Storage Characteristics for
Constructed Wetland (from Table 4)**

Stage (mAHD)	Storage (m ³)	Notes
0.3 – 0.8	6,580	Permanent Water Level – 0.8mAHD, approximately 25mm runoff depth from WesTrac site Start detention storage
0.9	9,580	
1.0	12,730	
1.1	16,200	Starting level of extended detention depth within perimeter drainage of WesTrac site
1.2	19,990	
1.3	24,060	Initial setting for spillway level, 17,480m ³ Extended detention storage is approximately 66mm runoff depth from WesTrac site
1.4	28,360	
1.5	32,890	
1.6	38,150	Level to which spillway can be raised without compromise of freeboard. Extended detention storage is approximately 120mm runoff depth from WesTrac site
1.7	43,600	
1.8	49,250	
1.9	55,190	Level of peak storage, top of berm surround to constructed wetland

Standard recurrence events of 1, 5, 10, 20, and 100 years were analysed as shown below in **Tables 15 – 19** respectively. Storm durations ranged from 10 minutes to 720 minutes (12 hours) to determine the peak flow from the constructed wetland.

Table 15 – Summary of Peak Discharges from RAFTS – 1:1 year ARI

Duration (mins)	Peak Discharge (m ³ /s)		Peak Stage in Constructed Wetland (mAHD)
	Existing	Post Development	
10	<0.01	0	0.85
30	0.04	0	0.91
60	0.83	0	0.96
90	0.86	0	0.99
120	0.95	0	1.02
180	0.88	0	1.05
270	1.11	0	1.08
360	0.95	0	1.01
540	1.01	0	1.16
720	1.06	0	1.19

Table 16 – Summary of Peak Discharges from RAFTS – 1:5 year ARI

Duration (mins)	Peak Discharge (m ³ /s)		Peak Stage in Constructed Wetland (mAHD)
	Existing	Post Development	
10	0.18	0	0.89
30	1.88	0	1.00
60	2.72	0	1.09
90	2.85	0	1.13
120	3.13	0	1.17
180	2.38	0	1.22
270	2.64	0	1.28
360	2.35	0	1.32
540	1.99	0	1.35
720	2.12	0	1.39

Table 17 – Summary of Peak Discharges from RAFTS – 1:10 year ARI

Duration (mins)	Peak Discharge (m ³ /s)		Peak Stage in Constructed Wetland (mAHD)
	Existing	Post Development	
10	0.55	0	0.91
30	2.48	0	1.04
60	3.38	0	1.12
90	3.59	0	1.17
120	3.81	0	1.21
180	2.94	0	1.27
270	3.09	0.08	1.33
360	2.69	0.24	1.36
540	2.36	0.42	1.38
720	2.43	0.71	1.42

Table 18 – Summary of Peak Discharges from RAFTS – 1:20 year ARI

Duration (mins)	Peak Discharge (m ³ /s)		Peak Stage in Constructed Wetland (mAHD)
	Existing	Post Development	
10	0.66	0	0.95
30	3.20	0	1.07
60	4.26	0	1.17
90	4.58	0	1.23
120	4.85	0	1.27
180	3.69	0.10	1.33
270	3.73	0.35	1.37
360	3.22	0.51	1.40
540	2.80	0.76	1.43
720	2.87	1.00	1.45

Table 19 – Summary of Peak Discharges from RAFTS – 1:100 year ARI

Duration (mins)	Peak Discharge (m ³ /s)		Peak Stage in Constructed Wetland (mAHD)
	Existing	Post Development	
10	1.68	0	1.00
30	4.96	0	1.16
60	6.06	0	1.28
90	6.51	0.12	1.34
120	6.78	0.38	1.38
180	5.19	0.72	1.42
270	4.91	0.95	1.45
360	4.11	1.03	1.45
540	3.54	1.59	1.50
720	3.68	1.57	1.50

The ‘post development simulation including the constructed wetland storage was based on an outlet configuration of a 10m wide spillway with a crest level of 1.3m AHD. The spillway as described in **Section 6.7**, will have adjustment to be set at a level as low as 1mAHD up to a top level of 1.6mAHD.

The RAFTS modelling simulations indicate that the constructed wetland has significant peak flow attenuation capacity. Peak flows have been reduced to low flows of less than 0.1m³/s for many of the storm durations from the low flow 250mm outlet, more than an order of magnitude lower than equivalent existing site discharges for the protection of the downstream channel conditions. Refer to **Section 8.3.4**.

8.3.4 Downstream Capacity

From Consent condition 12 (e), the requirement is to “demonstrate that the existing stormwater drainage channels have capacity to accommodate post development flows under a range of tidal conditions”. The issue of this condition is that there is potential for wetting and drying cycles to be affected in the downstream wetlands adjacent to the north-south channel, if the capacity is breached by smaller, regular storm events when these existing flows were previously contained to the channel. It is assumed that the channel in its existing, pre development state approximately 3m wide and 1.5m deep is operating with sufficient capacity.

As shown in **Section 8.3.3**, RAFTS modelling indicates that post development peak flows are consistently an order of magnitude less than existing peak flows. This indicates that the channel capacity will be greater following development with less potential for overtopping. The significant attenuation is due to a large extended detention capacity, taking a cautious approach to the surface water discharge.

Significant permanent water storage is provided to prevent any surface water discharge from the constructed wetland during smaller, regular storms. These storms have been targeted since these have the most potential to impact on wetting and drying cycles downstream. Accordingly, these storms are effectively captured.

Spillway flows from the constructed wetland during major storm events or long duration smaller storms are also attenuated to less than pre development peak flow levels. At this time, the whole area downstream will be saturated with fresh (rain) water, at which time there is no issue with wetting and drying cycles, although post development peak flows will still be considerably less than existing, pre development peak flows.

For these reasons, it is considered that the north-south drain has capacity to accommodate post development flows, however surface water discharge from the constructed wetland will be monitored.

The open channel drainage link from the constructed wetland to the north-south drain will be sized for the 1:100 year ARI storm event for the peak flows from the WesTrac Stage 1 site and future industrial stage adjacent. There is a minor existing farm drain over the boundary, however reservation has been made for drainage within the future industrial stage site boundaries for flow containment. Widening of this section of the channel will assist in improving the drainage for the site and the adjoining properties. Refer to **Figure 9**.

8.4 Miscellaneous Drainage Components

Major drainage flowpaths around the WesTrac facility have been identified and sized for stormwater conveyance and control. These include box culverts under the perimeter road and secondary flowpaths for stormwater from the rainwater tanks and hardstand areas. Provision has been made to collect existing pipe culvert drainage from under Tomago Road into the drainage corridor of the entry road. Full drainage of the Tomago Road intersection area will be required by the RTA with the intersection design. Flowpaths are shown in **Figure 9**.

8.4.1 Fill Elevation

The site will be filled to a minimum elevation of 2.3m AHD around the perimeter of the ring road of the WesTrac facility. This is closely equivalent to the peak 100 year recurrence regional flood level for the Hunter River. Finished floor levels of buildings will be 3.5m AHD - 4m AHD, well clear of the 1:100 year peak flood level. There is no impoundment of stormwater runoff upstream of the site as a result of the fill. Final levels are subject to detailed design.

8.4.2 Fill Quality

Geotechnical approval will be required on the fill type and its properties prior to being used on the site. This is because there can be potential impacts of leachates emanating from the fill and migrating downstream with stormwater runoff. Geotechnical advice has been provided, directing that granular material with particles not greater than 100mm diameter is preferred for use on the site. In particular, no ash is to be used for filling; due to its leachate potential. The fill to be used must be pH neutral and will be screened for properties under the supervision of geotechnical engineers, prior to supply to the site. This will mitigate any potential impacts of runoff from the fill to the wetlands.

9.0 Management, Monitoring and Reporting

The management, monitoring and reporting for stormwater management on site has been separated, into **Sections 9.1, 9.2 and 9.3** respectively.

9.1 Water Management

9.1.1 Rainwater Tank & Buildings

The distribution of rainwater tank water supply to uses around the site will be established with pump systems and gravitational systems where possible. Water will be chlorinated and conditioned prior to reuse as required for the various applications. Flow metering will be used as required for review of rainwater tank water usages and reporting. The details of this are subject to detailed design.

9.1.2 Trunk Drainage System

The following elements need to be considered during the operational phase of the constructed wetland and drainage system:

- performance of constructed wetland assessed against original objectives;
- assessment made through inspections;
- day-to-day management functions such as weed control and heavy sediment removal; and
- more infrequent management functions such as monitoring of the water drawdowns.

9.1.3 Operation and Maintenance

Maintenance activities may be prioritised with reference to the following issues:

- **Safety** – the safety of the work staff is of the highest priority;
- **Stability** – a failed structure may cause complete failure of the wetland. It is generally cheaper to maintain/ repair than to replace; and
- **All other management activities** – essential for the effective long-term performance of the wetland.

Management issues of particular relevance that need to be considered by the operator include:

- Storm and Flood Management;
- Plant Management and Weed Control;
- GPT Management;
- Pest Control; and
- Management of Sediment and Bioaccumulation of Toxic Materials.

These are discussed in the following sections below.

Storm and Flood Management – wetland should be inspected as soon as practicable after a storm or flood event. Repair of damage should be prompt to ensure wetland performance is maintained. Litter and sediment deposition will most likely be at its greatest during a storm event. Litter should be removed from all wetland zones and the Gross Pollutant Traps (GPT's) after each major storm.

Plant Management and Weed Control - the aim is to sustain a dense stand of desirable vegetation within the wetland. Gradual change in wetland vegetation should be expected, as a result of aggressive species out-competing more passive species. Certain plant species may also be introduced to the wetland from the catchment. Generally, the natural succession of wetland plants should be allowed without intervention. However, there are several aquatic weeds which may need management.

Plants may be in danger of desiccation during extended dry periods, therefore irrigation may be necessary. Terrestrial weed species may invade the drier areas of the wetland but will generally be drowned once normal operating water levels are established.

Most mature plants will be able to survive moderate (1-2 weeks) periods of inundation. Following floods or storms, an inspection of vegetation is advisable as plants may have been scoured from the wetland and/ or drowned. If areas of plants are lost, the cause should be established and recorded, and re-establishment carried out. Small areas will generally recover naturally, larger areas may require replanting. If erosion has occurred, the wetland substrate may require replacing prior to replanting. Professional advice should be sought if the damage is substantial.

If the constructed wetland needs to be drained for maintenance, mosquito or weed control, contact will need to be made with NPWS prior to any drawdown. Water quality monitoring will be essential on the fresh water being discharged. In such an event, water should be drained slowly to prevent erosion of the substrate. Precautions should be taken to protect the vegetation.

GPT Management - a Gross Pollutant Trap (GPT) or litter screen will trap significant amounts of heavy sediment from entering the constructed wetland. GPT's have been assembled at the end points of all piped drainage to capture litter prior to entering the swales. Periodic cleaning of the GPT's will be required and should be undertaken regularly or following a large storm event.

Debris may also accumulate throughout the wetland. To maintain optimum wetland performance, the litter and debris need to be removed periodically and immediately after storm events. Fouled areas will have a reduced performance owing to increased hydraulic pressure on the macrophytes and flattening of the plants. Litter removal will also enhance the wildlife habitat and scenic amenity within the wetland environs.

Pest Control - birds can be considered pests in certain circumstances. For example, birds can inhibit plant establishment by eating new shoots and seedlings. During dry periods, the wetland can attract large numbers of birds, potentially causing disinfection problems.

Mosquitoes are common in natural wetlands and may also be expected in constructed wetlands. A vector management plan has been completed and submitted to Department of Planning.

Management of Sediment and Bioaccumulation of Toxic Materials - sediment accumulation needs to be monitored within the constructed wetland and the bioretention trenches within the perimeter drainage swales. The majority of sediment collection will occur over and adjacent to the bioretention trench gravels of the swale prior to the stormwater discharging into the Caisson Wells. Some sediment build up is to be expected at the entry to the Caisson Wells which can be cleaned via the use of the adjoining maintenance pad. In larger storms, stormwater will bypass the Caisson Wells and discharge directly into the constructed wetland. To maintain the hydraulic conditions of the wetland and to prevent release of pollutants from sediments over time, accumulated sediment must be removed. Sediments must be disposed of in accordance with the *Waste Minimisation and Management Act, 1995*. This refers to the type and levels of contaminant testing required and the subsequent type of disposal that will be allowed, which may require consent.

Inspections - will direct what maintenance is required and should be conducted at regular intervals of at least 3 months. The constructed wetland has been designed to accommodate easy inspection and resulting maintenance with the embankment berm large enough to accommodate vehicular movement. Inspections are also necessary following storm events or any other event that may damage wetland function, e.g. floods, fire and chemicals spills. An Inspection Checklist is shown in **Appendix D**.

9.2 Monitoring Strategy

For details of the revised surface water monitoring procedures refer to **Appendix F of the SWMP**, prepared by Douglas Partners dated 26 November 2025.

Flow measuring instrumentation will be used at the constructed wetland outlet to measure flow quantity.

9.3 Reporting

For details of the proposed surface water reporting, refer to **Appendix F of the SWMP**, prepared by Douglas Partners dated 26 November 2025.

Flow measurement results will be compared to Williamstown rainfall data and reviewed against the Hunter Water monitoring data for regional groundwater levels. Options for any changes should be verified by a professional stormwater engineer and raised with authorities.

10.0 References

- “Tomago Wetlands Final Report – Modelling Results” Issue No. 4 March 2004, issued by Patterson Britton & Partners for Department of Commerce;
- “Tomago Wetland Hydrological Study, Kooragang Nature Reserve” Technical Report 2005/28 September 2005, WC Glamore, KM Hawker and BM Miller;
- “Hunter Estuary Issues Paper Hunter Coast and Estuary Management Committee” March 2005, issued by WBM Oceanics and Parsons Brinckerhoff.
- “Review of Environmental Factors Tomago Rehabilitation Project Kooragang Nature Reserve” October 2005, NPWS.
- “Westrac Development Review” (letter), 11 November 2009, BMT WBM
- “Redlake Mixed Use Development at Tomago, NSW” (Letter), 26 November 2008, issued by Equatica
- “Acid Sulphate Soil Management Plan” Project 39920.02 November 2009, issued by Douglas Partners
- “Groundwater Monitoring Plan” Project 39920.02 November 2009, issued by Douglas Partners
- “Report on Assessment of Proposed Stormwater Infiltration” Project 39920.02 December 2009, issued by Douglas Partners
- “Volume 3 – Stormwater Management Report – WesTrac facility” Version 1 November 2007, issued by Asquith & de Witt
- “Managing Urban Stormwater Soils and Construction” (Blue Book) 4th Edition, Volume 1, March 2004 produced by Landcom.
- “Water Sensitive Urban Design Solutions for Catchments above Wetlands”, May 2007, Hunter & Central Coast Regional Environmental Management Strategy (HCCREMS).
- “Australian Water Quality Guidelines for Fresh and Marine Waters”, November 2000, ANZECC.
- “Australian Drinking Water Guidelines”2004, National Health and Medical Research Council (NHMRC).
- “Managing urban stormwater: Consultation draft” October 2007, Department of Environment and Climate Change.
- “Volume 2 – Concept Engineering, Servicing and Earthworks Report – Overall” Version 1 November 2007, issued by Asquith & de Witt.

Torque Projects Pty Limited (Torque) has prepared this report solely for the purpose of updating the monitoring section and to only address minor authority comments of clarification. Douglas Partners Pty Limited has completed the updated monitoring section. This update is for the exclusive use of Northbank Enterprise Hub Pty Limited. The original strategy, design, modelling, figures, consultation and approvals were completed by ADW Johnson Pty Limited prior to Stage 1 construction. Torque is reliant on this previous report by ADW Johnson and accordingly, Torque does not warrant that the document is free from error or omissions arising from these factors and does not accept liability for any such errors or omissions. It should not be used by or relied upon for other projects or purposes on the same or other site or by a third party. Any party so relying upon this report beyond its exclusive use and purpose as stated above, and without the express written consent of Torque, does so entirely at its own risk and without recourse to Torque for any loss or damage.

Figures

- Figure 1 - Site Location
- Figure 2 – Existing Site
- Figure 3 – Development Layout
- Figure 4 – Modifications to Stormwater Management
- Figure 5 – Site Cross Section
- Figure 6 – Water Balance Model Network
- Figure 7 – Soil & Water Management
- Figure 8 – Erosion and Sediment Control Details
- Figure 9 – Stormwater Management
- Figure 10 – MUSIC Model Layouts

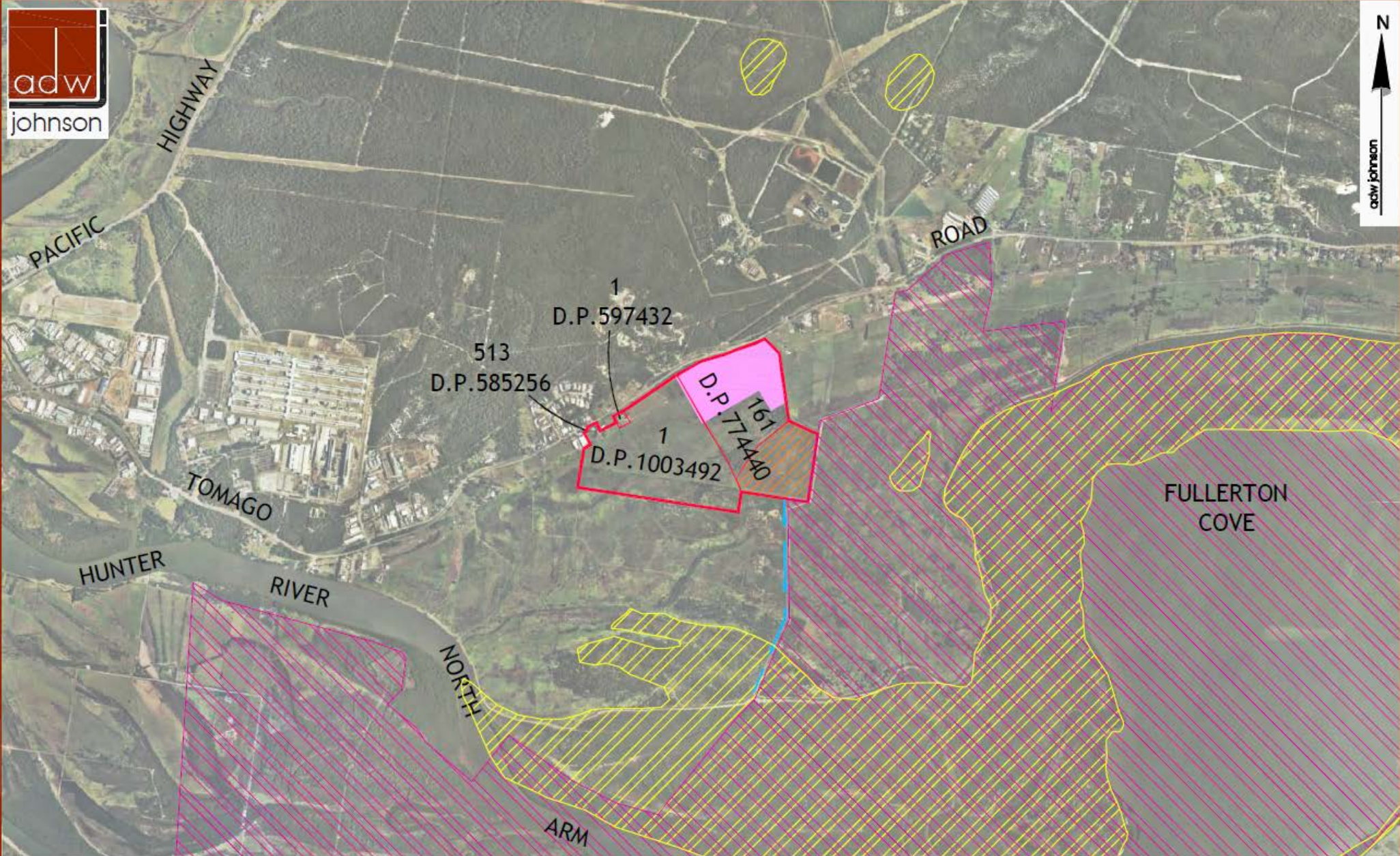

COPYRIGHT NOTICE
THIS PLAN AND THE INFORMATION IT CONTAINS ARE COPYRIGHT AND REMAIN THE PROPERTY OF ADW Johnson Pty Ltd. ADW Johnson Pty Ltd GRANTS TO THE CLIENT NAMED ON THIS PLAN A LICENCE TO USE THE INFORMATION HEREON FOR THE PURPOSE FOR WHICH WE WERE ENGAGED TO PERFORM THE WORK. USE OF THE PLAN AND INFORMATION IT CONTAINS FOR ANY OTHER PURPOSE IS NOT PERMITTED UNLESS PRIOR WRITTEN APPROVAL HAS BEEN OBTAINED FROM ADW Johnson Pty Ltd.



- SITE BOUNDARY
- NORTH-SOUTH DRAIN
- PROPOSED WESTRAC SITE (STAGE 1)
- SEPP 14 WETLAND AREA
- RAMSAR WETLAND AREA
- PROPOSED NPWS BUFFER AREA

FIGURE 1
SITE LOCATION

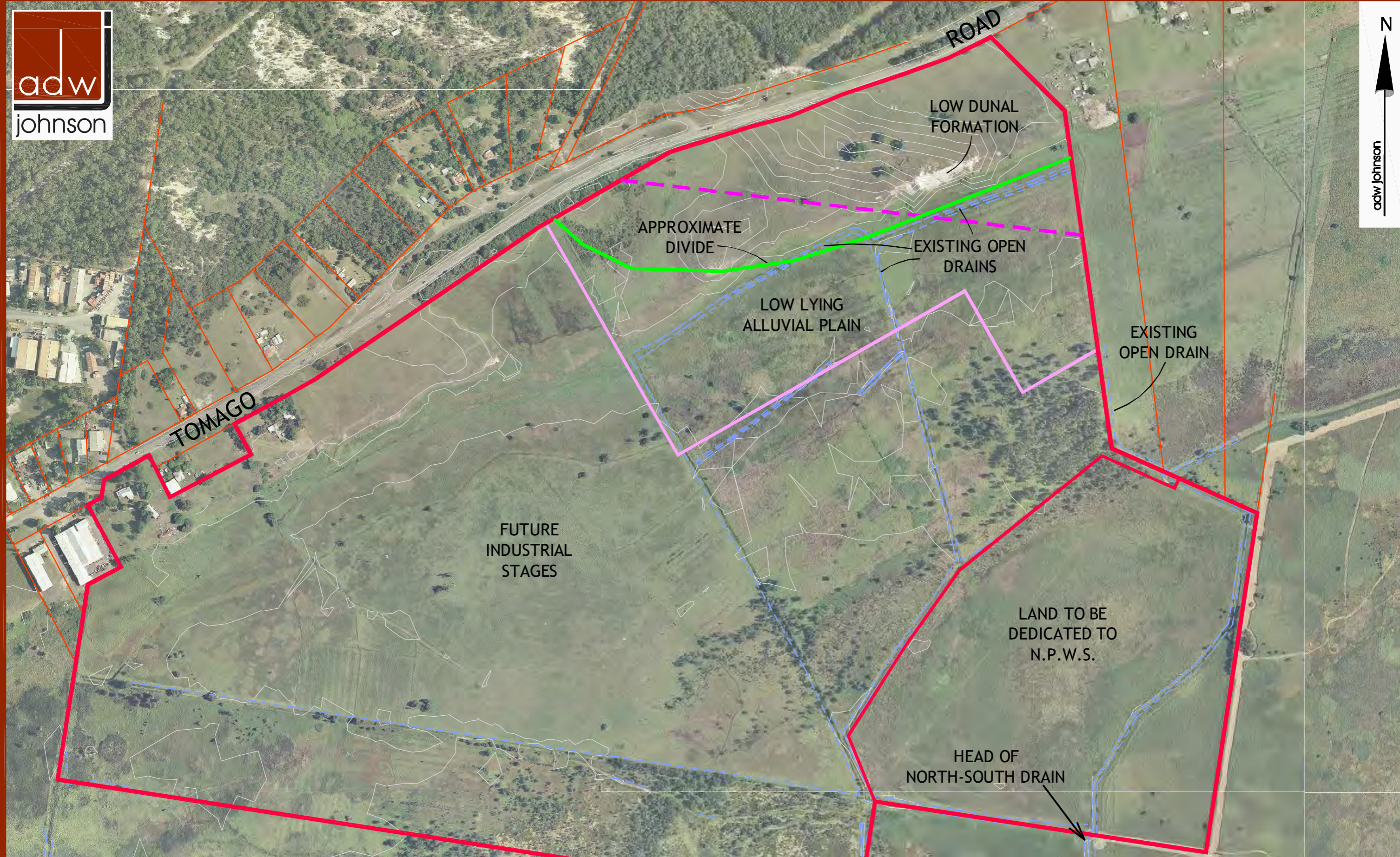

"COPYRIGHT NOTICE"
THIS PLAN AND THE INFORMATION IT CONTAINS ARE COPYRIGHT AND REMAIN THE PROPERTY OF ADW Johnson Pty Ltd. ADW Johnson Pty Ltd GRANTS TO THE CLIENT NAMED ON THIS PLAN A LICENCE TO USE THE INFORMATION HEREON FOR THE PURPOSE FOR WHICH WE WERE ENGAGED TO PERFORM THE WORK. USE OF THE PLAN AND INFORMATION IT CONTAINS FOR ANY OTHER PURPOSE IS NOT PERMITTED UNLESS PRIOR WRITTEN APPROVAL HAS BEEN OBTAINED FROM ADW Johnson Pty Ltd.

- SITE BOUNDARY
- SURROUNDING BOUNDARIES
- - - - OPEN DRAIN
- WESTRAC BOUNDARY (STAGE 1)
- - - - HWC SPECIAL AREA

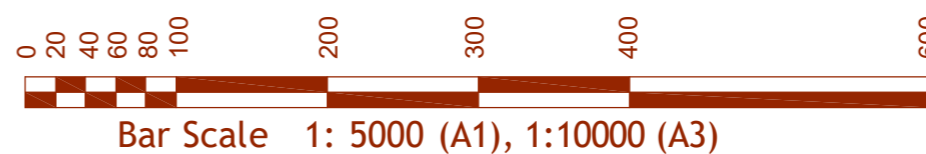
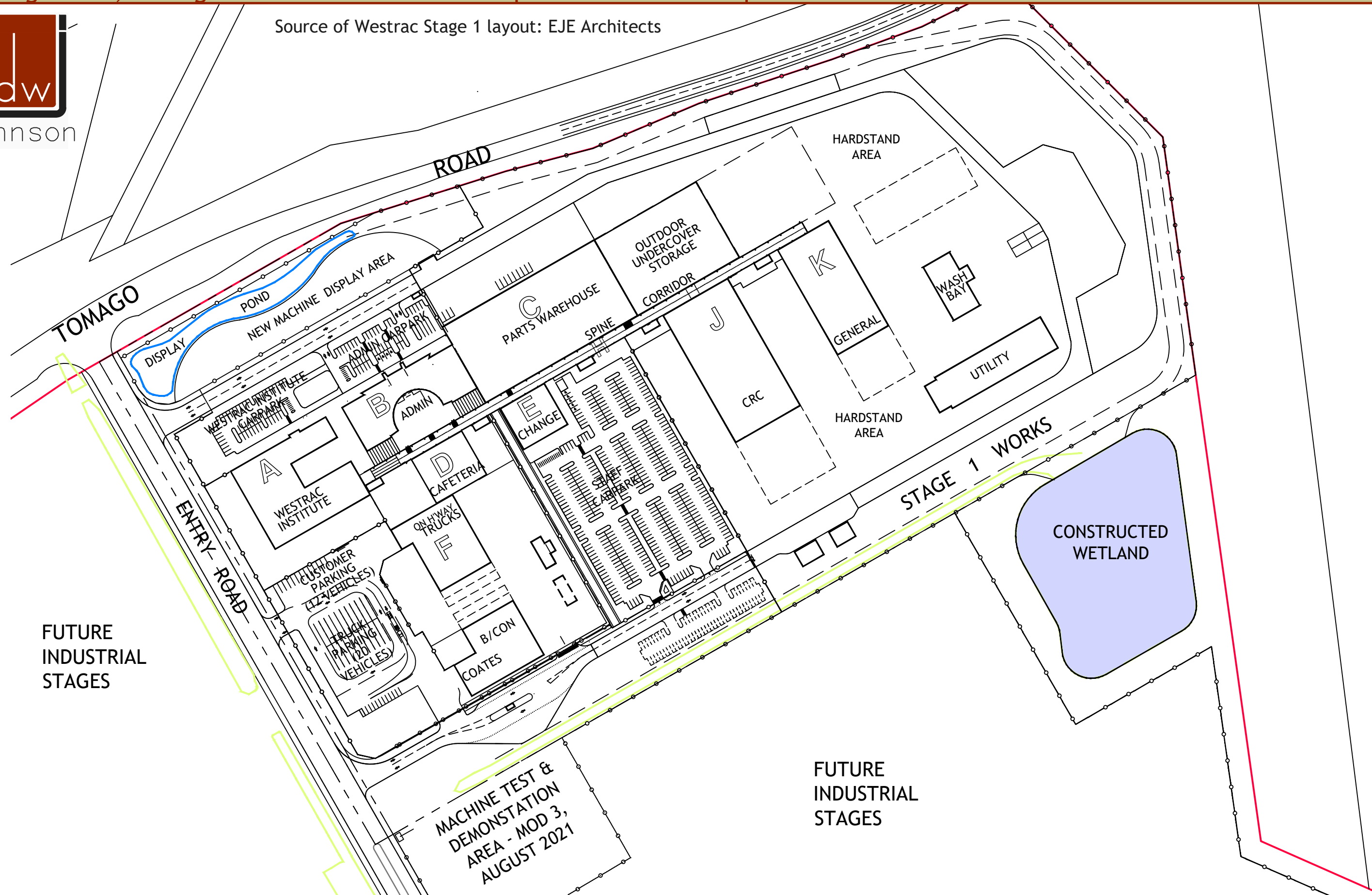

FIGURE 2
EXISTING SITE



Source of Westrac Stage 1 layout: EJE Architects



"COPYRIGHT NOTICE"
THIS PLAN AND THE INFORMATION IT CONTAINS ARE COPYRIGHT AND REMAIN THE PROPERTY OF ADW Johnson Pty Ltd. ADW Johnson Pty Ltd GRANTS TO THE CLIENT NAMED ON THIS PLAN A LICENCE TO USE THE INFORMATION HEREON FOR THE PURPOSE FOR WHICH WE WERE ENGAGED TO PERFORM THE WORK. USE OF THE PLAN AND INFORMATION IT CONTAINS FOR ANY OTHER PURPOSE IS NOT PERMITTED UNLESS PRIOR WRITTEN APPROVAL HAS BEEN OBTAINED FROM ADW Johnson Pty Ltd.



FIGURE 3
DEVELOPMENT LAYOUT

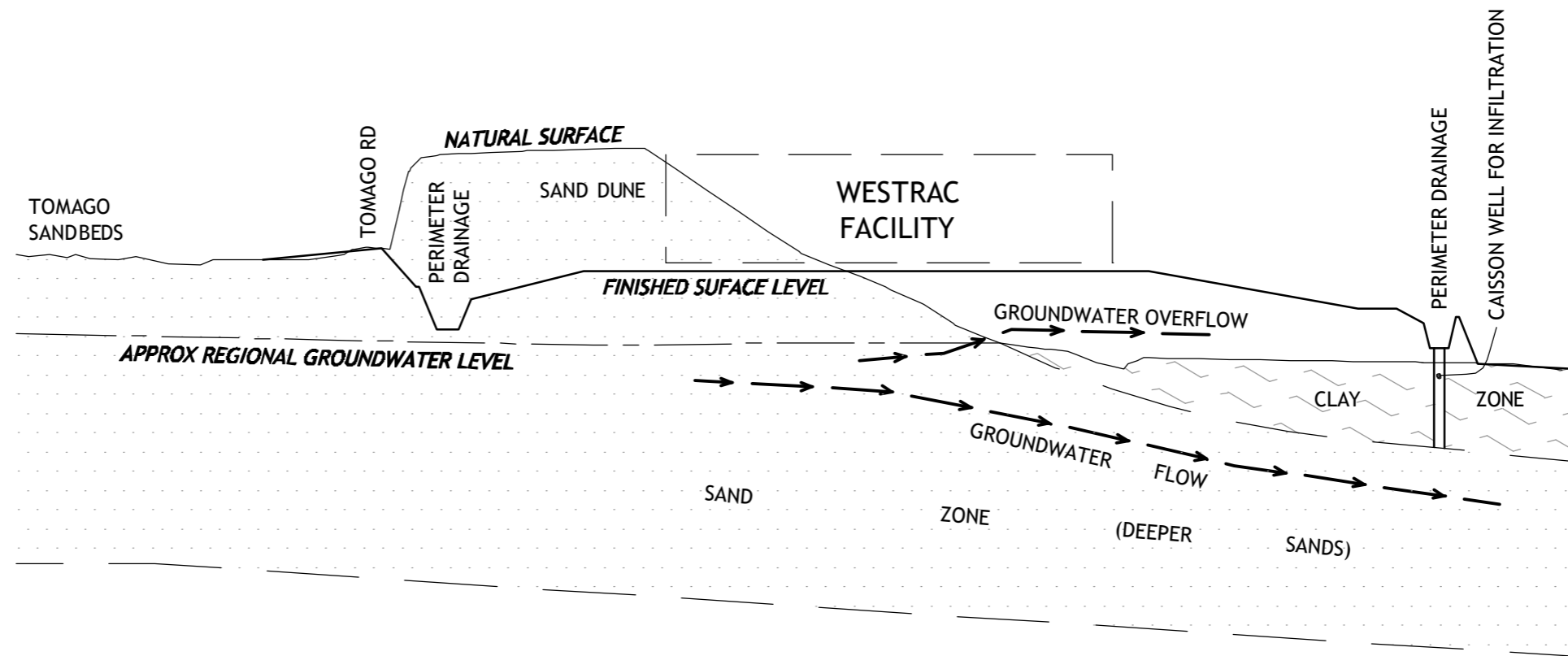
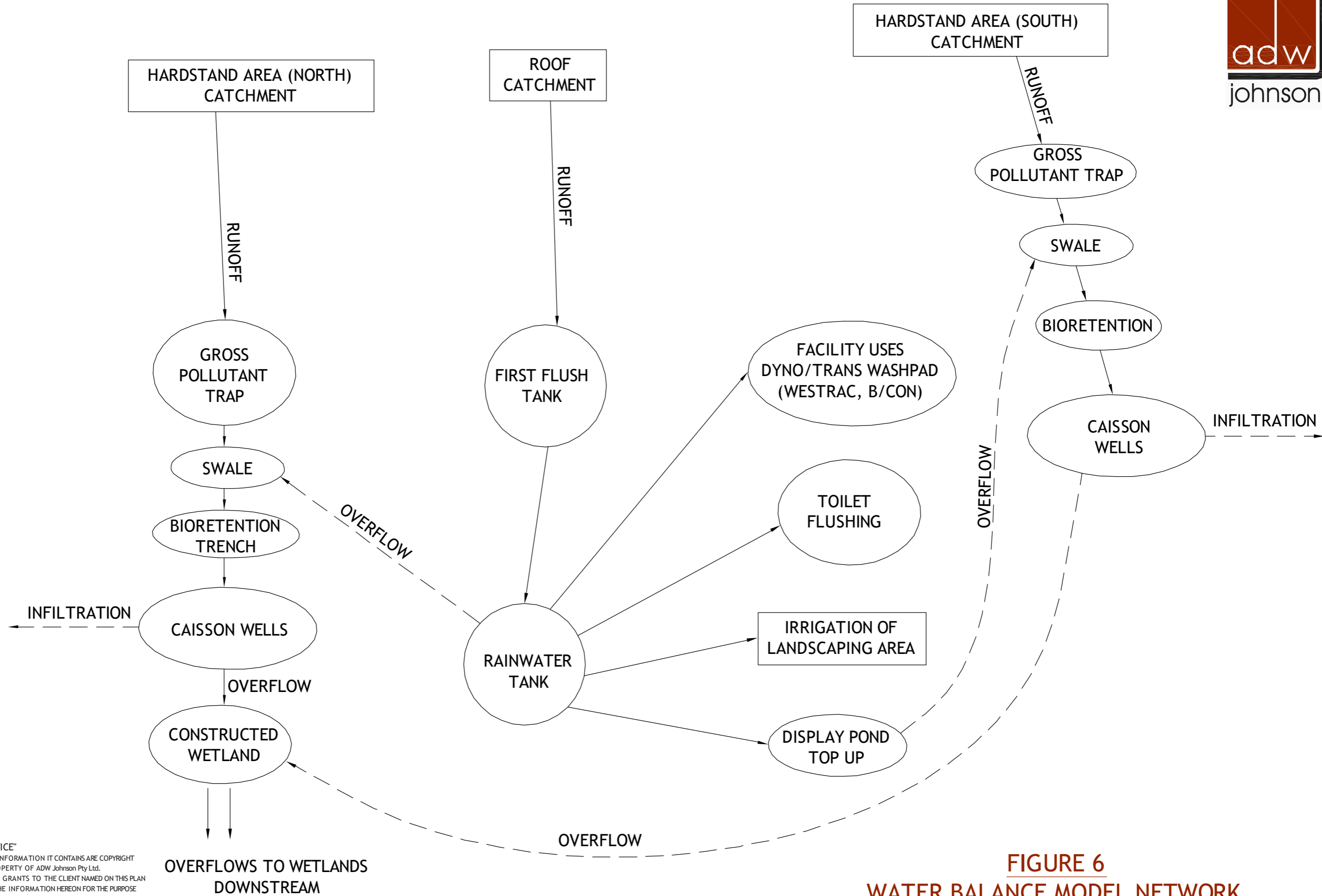

FIGURE 5
SITE CROSS SECTION
Not to Scale

"COPYRIGHT NOTICE"

THIS PLAN AND THE INFORMATION IT CONTAINS ARE COPYRIGHT AND REMAIN THE PROPERTY OF ADW Johnson Pty Ltd. ADW Johnson Pty Ltd GRANTS TO THE CLIENT NAMED ON THIS PLAN A LICENCE TO USE THE INFORMATION HEREON FOR THE PURPOSE FOR WHICH WE WERE ENGAGED TO PERFORM THE WORK. USE OF THE PLAN AND INFORMATION IT CONTAINS FOR ANY OTHER PURPOSE IS NOT PERMITTED UNLESS PRIOR WRITTEN APPROVAL HAS BEEN OBTAINED FROM ADW Johnson Pty Ltd.

REFER TO DOUGLAS PARTNERS REPORT.
APPENDIX B



"COPYRIGHT NOTICE"
THIS PLAN AND THE INFORMATION IT CONTAINS ARE COPYRIGHT AND REMAIN THE PROPERTY OF ADW Johnson Pty Ltd. ADW Johnson Pty Ltd GRANTS TO THE CLIENT NAMED ON THIS PLAN A LICENCE TO USE THE INFORMATION HEREON FOR THE PURPOSE FOR WHICH WE WERE ENGAGED TO PERFORM THE WORK. USE OF THE PLAN AND INFORMATION IT CONTAINS FOR ANY OTHER PURPOSE IS NOT PERMITTED UNLESS PRIOR WRITTEN APPROVAL HAS BEEN OBTAINED FROM ADW Johnson Pty Ltd.

FIGURE 6
WATER BALANCE MODEL NETWORK

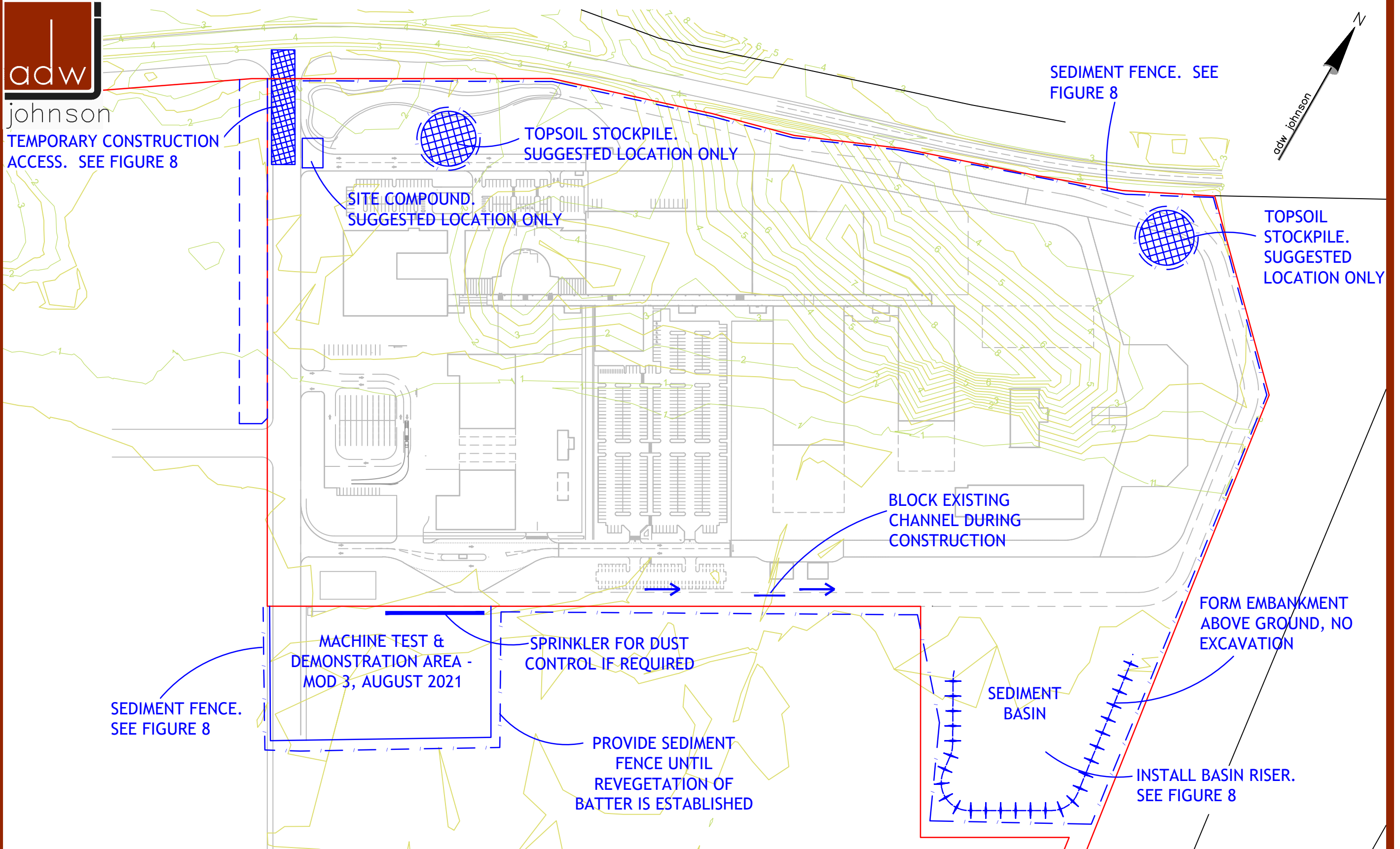
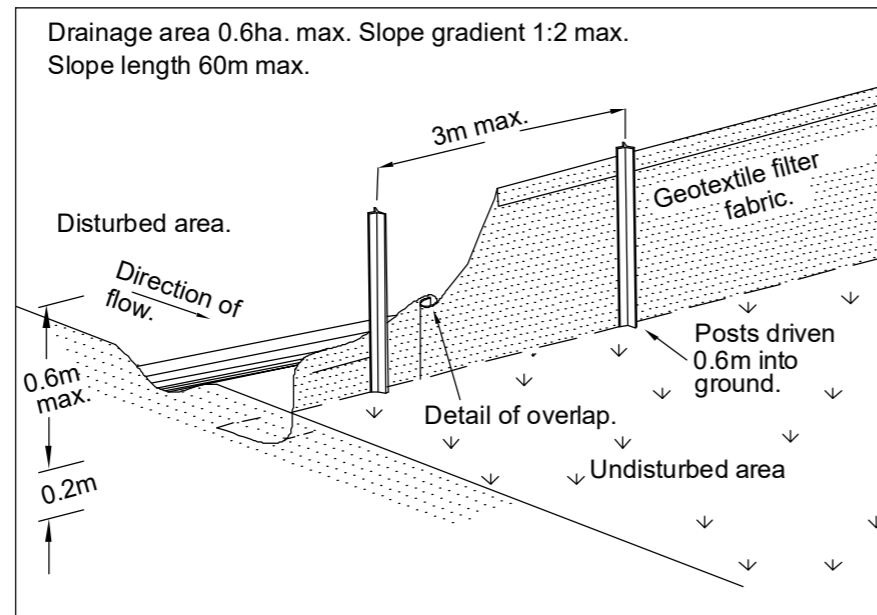
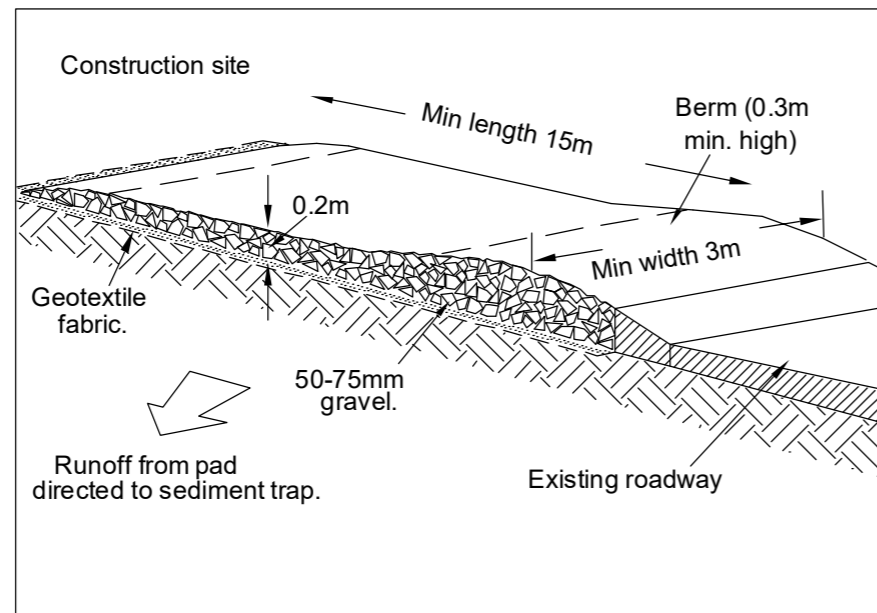

FIGURE 7
SOIL AND WATER MANAGEMENT

"COPYRIGHT NOTICE"
THIS PLAN AND THE INFORMATION IT CONTAINS ARE COPYRIGHT AND REMAIN THE PROPERTY OF ADW Johnson Pty Ltd. ADW Johnson Pty Ltd GRANTS TO THE CLIENT NAMED ON THIS PLAN A LICENCE TO USE THE INFORMATION HEREON FOR THE PURPOSE FOR WHICH WE WERE ENGAGED TO PERFORM THE WORK. USE OF THE PLAN AND INFORMATION IT CONTAINS FOR ANY OTHER PURPOSE IS NOT PERMITTED UNLESS PRIOR WRITTEN APPROVAL HAS BEEN OBTAINED FROM ADW Johnson Pty Ltd.



SEDIMENT FENCE



TEMPORARY CONSTRUCTION ACCESS

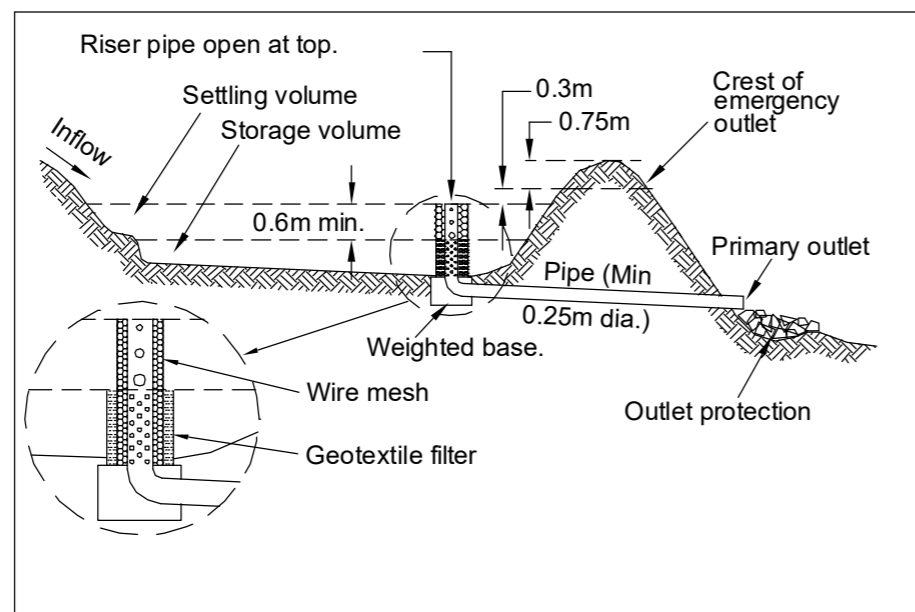

BASIN RISER

NOTES

- (a) Upon completion of final earthworks or after written direction of Council, immediate soil conservation treatments shall be applied so as to render areas that have been disturbed, erosion proof in 30 days.
- (b) All perimeter and siltation control measures are to be the first step in clearing or earthworks.
- (c) The area over all stormwater and sewer lines not within the roads are to be strip turfed on the contour as soon as possible but no later than 7 days after backfill. Max spacing of strip turf to be 4 metres
- (d) No more than 150 metres of trench are to be open at any one time.
- (e) Areas over electricity, telephone and gas supply trenches are to be seeded and mulched as soon as possible, but no later than, 7 days after backfill.
- (f) All temporary earth berms, diversion and sediment basin embankments are to be track rolled and seeded or mulched for temporary vegetation cover as soon as they have been formed.
- (g) All fills are to be left with a windrow at least 200mm high at the top of the slope at the end of each days earthworks, and all earthwork areas shall be rolled each evening to "seal" the earthworks.
- (h) All final erosion prevention measures, including establishment of grassing, are to be completed prior to the subdivision final inspection.
- (i) A strip of turf is to be placed immediately behind the kerb and gutter on all new roads and at any additional locations determined by Council's Supervising Officer.
- (j) All topsoil is to be stockpiled on site for re-use (away from trees and drainage lines). Measures shall be applied to prevent erosion from the stockpiles.
- (k) Establishment of fire breaks shall be carried out in consultation with the Fire Control Officer and Council's Environment Officer.
- (l) Temporary sand bag sediment traps are to be placed at each drainage pit. Sand bags are to be used to construct temporary sediment traps at each kerb inlet.
- (m) All disturbed areas are to be stabilised and/or revegetated within 14 days of earthworks completion, using turf or the following seed and fertilizer mixture:

	SPRING/SUMMER	AUTUMN/WINTER
Japanese Millet	10kg/Ha	
Ryecom/Oats		15kg/Ha
Couch Grass	10kg/Ha	8kg/Ha
Perennial Grass	5kg/Ha	10kg/ha
Starter Fertilizer (Sowing)	300kg/Ha	300kg/Ha
Maintenance Fertilizer	100kg/Ha	100kg/Ha

FIGURE 8
STANDARD EROSION AND
SEDIMENT CONTROLS

"COPYRIGHT NOTICE"
THIS PLAN AND THE INFORMATION IT CONTAINS ARE COPYRIGHT AND REMAIN THE PROPERTY OF ADW Johnson Pty Ltd.
ADW Johnson Pty Ltd GRANTS TO THE CLIENT NAMED ON THIS PLAN A LICENCE TO USE THE INFORMATION HEREON FOR THE PURPOSE FOR WHICH WE WERE ENGAGED TO PERFORM THE WORK.
USE OF THE PLAN AND INFORMATION IT CONTAINS FOR ANY OTHER PURPOSE IS NOT PERMITTED UNLESS PRIOR WRITTEN APPROVAL HAS BEEN OBTAINED FROM ADW Johnson Pty Ltd.

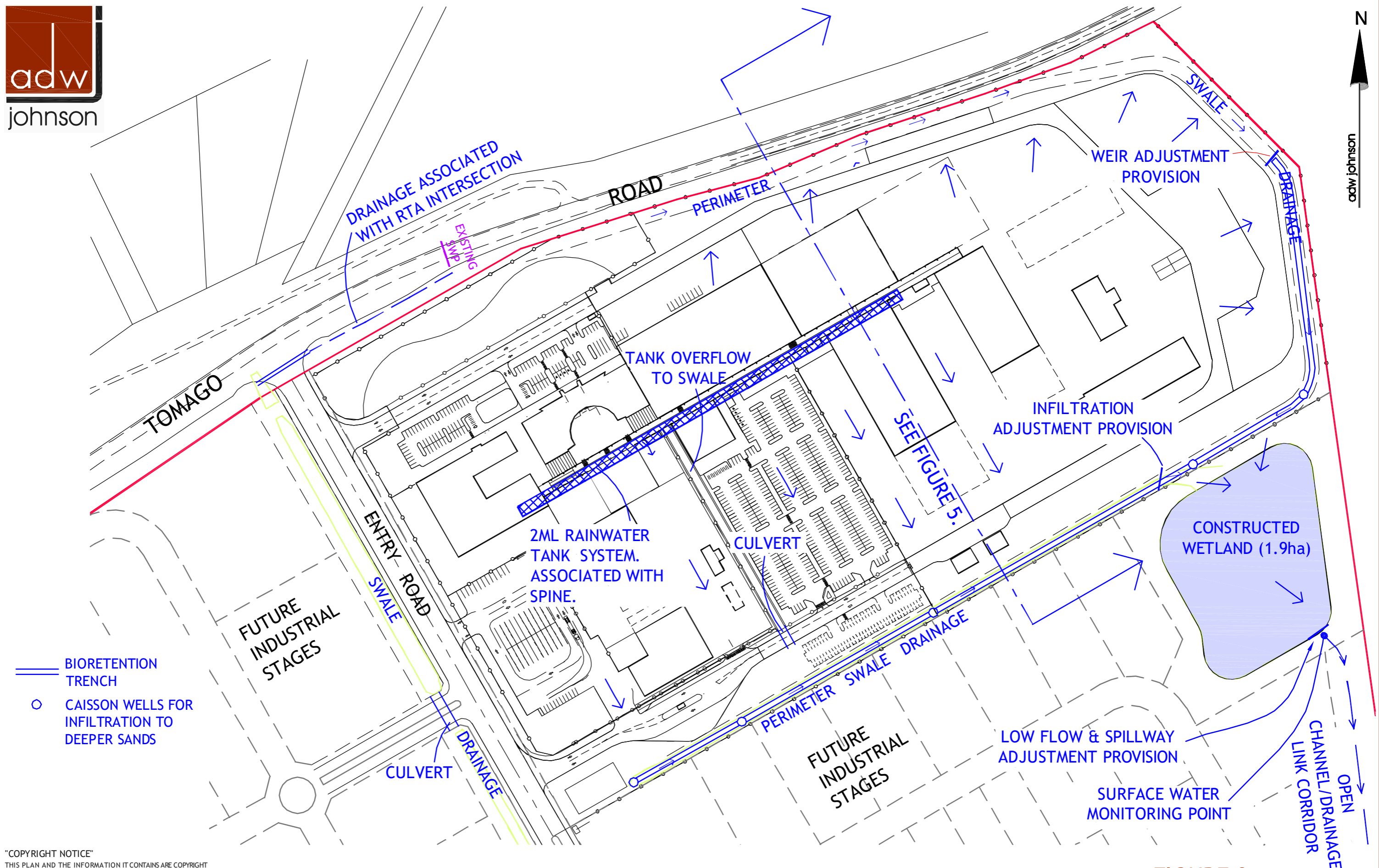

"COPYRIGHT NOTICE"
THIS PLAN AND THE INFORMATION IT CONTAINS ARE COPYRIGHT AND REMAIN THE PROPERTY OF ADW Johnson Pty Ltd. ADW Johnson Pty Ltd GRANTS TO THE CLIENT NAMED ON THIS PLAN A LICENCE TO USE THE INFORMATION HEREON FOR THE PURPOSE FOR WHICH WE WERE ENGAGED TO PERFORM THE WORK. USE OF THE PLAN AND INFORMATION IT CONTAINS FOR ANY OTHER PURPOSE IS NOT PERMITTED UNLESS PRIOR WRITTEN APPROVAL HAS BEEN OBTAINED FROM ADW Johnson Pty Ltd.



FIGURE 9
STORMWATER MANAGEMENT

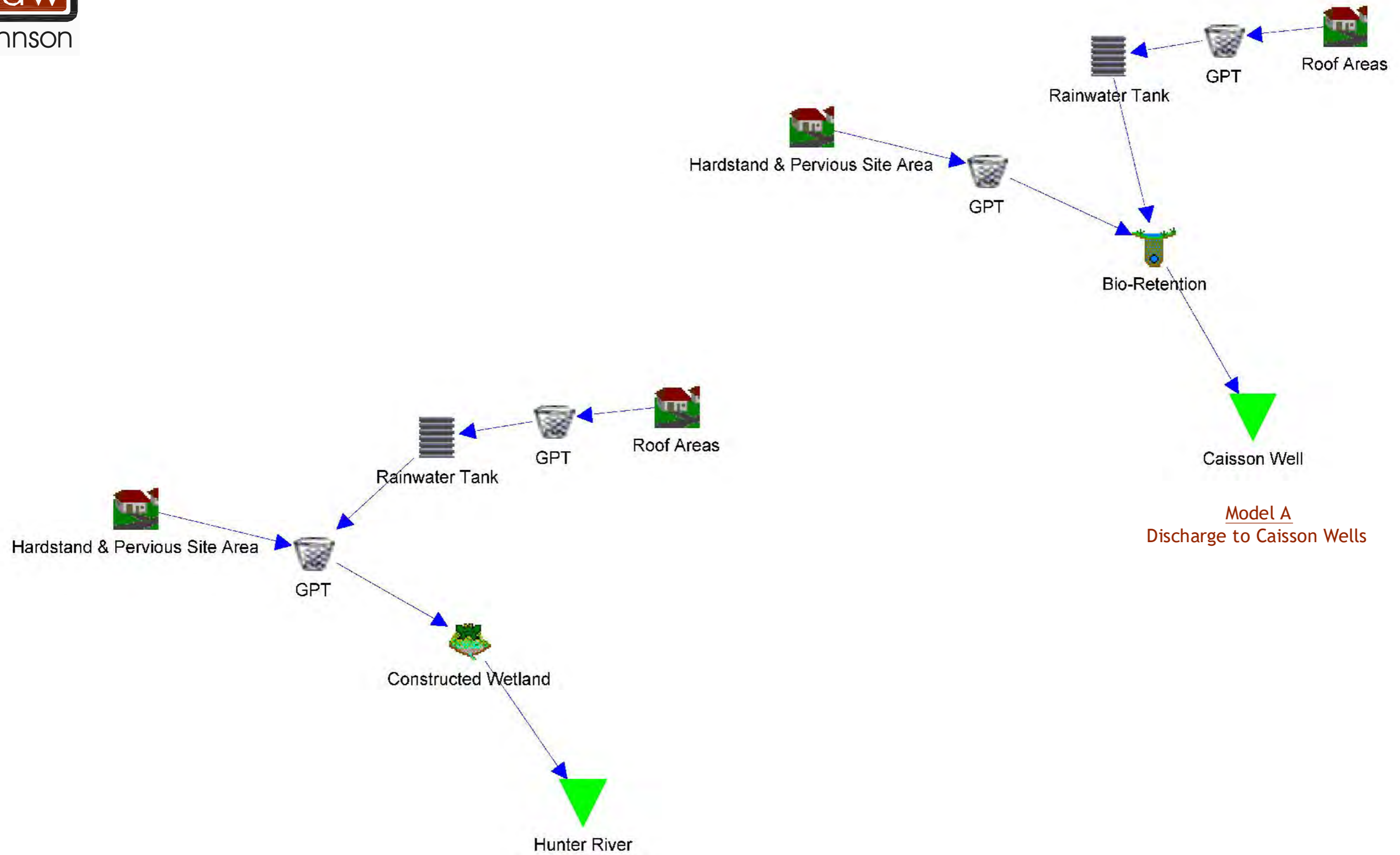

Model A
Discharge to Caisson Wells

Model B
Discharge to Constructed Wetlands

FIGURE 10
MUSIC MODEL LAYOUTS
Not to Scale

"COPYRIGHT NOTICE"
THIS PLAN AND THE INFORMATION IT CONTAINS ARE COPYRIGHT AND REMAIN THE PROPERTY OF ADW Johnson Pty Ltd. ADW Johnson Pty Ltd GRANTS TO THE CLIENT NAMED ON THIS PLAN A LICENCE TO USE THE INFORMATION HEREON FOR THE PURPOSE FOR WHICH WE WERE ENGAGED TO PERFORM THE WORK. USE OF THE PLAN AND INFORMATION IT CONTAINS FOR ANY OTHER PURPOSE IS NOT PERMITTED UNLESS PRIOR WRITTEN APPROVAL HAS BEEN OBTAINED FROM ADW Johnson Pty Ltd.

Appendix A – BMT WBM Letter Review for NPWS

Our Ref: MEW: L.N1826.001

11 November 2009

NSW National Parks and Wildlife Service
PO Box 351
JESMOND NSW 2299

Attention: Jo Erskine

Dear Jo

RE: PROPOSED WESTRAC DEVELOPMENT, TOMAGO ROAD, TOMAGO

1 Introduction

WesTrac are proposing a new industrial development within a 26.3ha site located along Tomago Road at Tomago. We understand that the NSW National Parks and Wildlife Service (NPWS) is concerned that the proposed development may result in elevated freshwater flows and associated water levels in the Tomago north-south drain. This has the potential to increase freshwater discharge into an area of recently rehabilitated salt marsh. The salt marsh is located downstream of the proposed development on the eastern side of the Tomago north-south drain. Connection between the drain and salt marsh is currently via a lowered section of the drain's bank (refer to Photo 1) which allows larger tides to inundate the salt marsh when the Hunter River flood gates are open. NPWS is planning to expand the salt marsh rehabilitation area to the western side of the drain in the near future (pers. com. Jo Erskine).



Photo 1 Overflow from Tomago North-South Drain into rehabilitated salt marsh

2 Hydrology Review

NPWS has requested that BMT WBM review the stormwater management report (SMR) prepared for the development (*Environmental Assessment Report, Tomago Road, Tomago – Volume 3 Stormwater Management Report WesTrac facility Version 1, November 2007 prepared by Asquith & DeWitt*) and provide comments on the hydrologic assessment. Our comments on the hydrologic assessment are outlined below.

2.1 Rainfall

A mean annual rainfall of 1110mm for the site was adopted in the SMR and this agrees with our understanding of the climatic conditions for this area. We understand that hydrologic modelling completed for the SMR applied rainfall data representative of these conditions. Based on the site area of 26.3ha, this represents an average annual rainfall volume of 292ML/yr.

2.2 Existing Site Hydrology – HWC Special Area

It was estimated within the SMR that the site area overlying the Hunter Water Corporation (HWC) Special Area (Tomago sand beds) is 9.59ha. The existing scenario modelling results within the SMR indicate that 106ML/yr would be infiltrated in the HWC special area which is equivalent to 100% recharge over the 9.59ha of HWC Special Area (i.e. it was assumed that 100% of rainfall will infiltrate to groundwater). Whilst the sub-soils in the special area are likely to comprise highly permeable sands (as confirmed by geotechnical investigations) it is considered that 100% recharge is a significant overestimate of the groundwater recharge within the existing site.

The proportion of rainfall that infiltrates and percolates to groundwater is influenced by a number of factors including rainfall intensity, depression storage, surface crusting, vegetation interception, unsaturated soil storage depth, soil field capacity and evapotranspiration. Considering the typical soil characteristics in the HWC Special Area we would expect that over a long-term period the proportion of rainfall that recharges groundwater would be approximately 40% to 50%. The remaining proportion of rainfall volume would either evaporate from the upper soil layers, and depression/interception storages, or be transpired by the vegetation cover. It is expected that only a very minor proportion of long term rainfall would become surface runoff in these areas. We would expect that the existing recharge volume in the HWC Special Area within the site is likely to be closer to 50ML/yr.

2.3 Existing Site Hydrology – Remaining Site Area (16.71ha)

The existing scenario modelling results in the SMR for the proportion of the site that overlies the clay soils suggest that an estimated average surface runoff of 93ML/yr would occur from this section of the site which drains to the wetland (i.e. the non HWC Special Area proportion of the site). Assuming that this runoff occurs from 16.71ha (26.3ha – 9.59ha), the total rainfall is 185ML/yr and the volumetric runoff co-efficient would be 0.5 (93/185).

In typical situations it is expected that a volumetric runoff co-efficient of 0.3 would be applicable to sites in this region that are dominated by clay sub-soils. Whilst it is considered that a runoff co-efficient of 0.5 is higher than typical, it is possible due to the expected frequently saturated soils, high groundwater table and existing drains within the site that a higher value may be reasonable.

2.4 Future Site Hydrology

The proposed development would result in approximately 80% of the existing site being covered by impervious surfaces or surface water storages. The remaining 20% would primarily be pervious landscaping, infiltration and swale areas. Although not confirmed in the SMR, it is envisaged that approximately 90% of rainfall on the impervious surfaces, and 30% of rainfall on pervious surfaces, would become surface runoff. Based on these estimates, sources within the site would generate an average surface runoff volume of approximately 228ML/yr following development.

The SMR indicates that a 2ML rainwater tank would be provided and this would supply 93% of non-potable water demands within the site. The estimated non-potable water demand within the site of 32.5kL/day equates to an annual demand of approximately 10ML/yr based on an average 6 day working week.

Evapotranspiration from the constructed wetland would also potentially reduce discharge from the site by approximately 15ML/yr.

2.5 Summary

Our understanding of the site water balance/hydrology based upon the available data is summarised below.

- Pre-development:
 - Rainfall = 292ML/yr
 - Surface runoff + infiltration within clay soil area = 93ML/yr
 - Groundwater recharge within HWC Special Area = 50ML/yr
 - Total surface runoff + infiltration/groundwater recharge = 143ML/yr
 - Evapotranspiration = 149 ML/yr
- Post development:
 - Rainfall = 292ML/yr (without climate change)
 - Surface runoff (at source) = 228ML/yr
 - Rainwater capture and use = 10ML/yr
 - Constructed wetland evapotranspiration = 15ML/yr
 - Surface runoff (discharge) = ?
 - Infiltration/groundwater recharge = ?
 - Total surface runoff (site discharge) + infiltration/groundwater recharge = 203ML/yr
 - Evapotranspiration = 79 ML/yr

Based on the above, it is estimated that the development is likely to result in an increase in surface runoff + infiltration/groundwater recharge of approximately 60ML/yr (203 –143). It is unclear from the data presented in the SMR what the distribution of this additional discharge between surface flow and groundwater would be. The increase in surface runoff + infiltration/groundwater recharge following development is due to a reduced potential for storing water in the soil which is a result of covering previously pervious surfaces with impervious roofs and paved areas. Once covered, these areas are ineffective in storing water that the becomes available for evapotranspiration.

The SMR indicates that a constructed wetland with a surface area of 11000m², permanent storage volume of approximately 5500m³ (average 0.5m deep) and temporary extended detention volume of 7,150m³ is proposed for the site. The constructed wetland has sufficient permanent storage for an approximate 20mm runoff depth from the entire site and extended detention of approximately 25mm runoff depth. Additional measures provided in series prior to the constructed wetland including a rainwater tank and swales would enable additional runoff to be intercepted. It is expected that the size of this storage is sufficient to manage surface runoff during all but the largest events.

Discharge from the proposed constructed wetland would be into the Tomago north-south drain. Discharge would primarily be through a low flow pipe designed to optimise stormwater quality management. During large events where the maximum storage level within the constructed wetland is exceeded, controlled overflow through a high flow weir would be discharged to the drain. It will be important that the outlet design from the constructed wetland ensures the additional runoff from the site is discharged in a manner that does not increase the risk of more frequent freshwater discharges into the salt marsh.

3 Conclusions

It is our opinion that the proposed WesTrac development will result in an additional 60ML/yr of runoff being discharged either via surface runoff or infiltration/groundwater recharge from the development site. It is unclear from data presented in the SMR what the proportional distribution of this increased flow between surface runoff and infiltration/groundwater recharge is likely to be. The proportional distribution will depend on the infiltration effectiveness, as any surface runoff unable to be infiltrated will overflow to the constructed wetland and discharge as surface water from the site.

Surface runoff will discharge from the site through a proposed constructed wetland. It will be important that the outlet from the constructed wetland is designed appropriately to ensure that discharges to the Tomago north-south drain are managed to avoid increased overflow of freshwater into the rehabilitated salt marsh area. It will be important that the outlet is designed to be adaptable to changes deemed necessary following review of post development monitoring. It may be desirable (where possible) to minimise freshwater discharges during events coinciding with high tides and only release this flow on the ebb tide. Although, this strategy would only be effective when the average runoff depth for a particular event is less than 25mm.

To monitor freshwater discharges into the salt marsh during the operational phase, a continuously sampling pressure sensor/electrical conductivity probe could be installed near the overflow point into the salt marsh area. Similarly a flow measuring instrument should be provided to monitor discharges from the constructed wetland. The two instruments should be synchronised.

Infiltration discharges and groundwater recharge from the site will be more difficult to monitor. We understand that the development proponent is currently considering alternative options for infiltrating runoff within the site and assessing the feasibility of these options. Our understanding is that the following two main options are being considered for infiltration:

- Infiltration into the highly permeable sands in the HWC Special Area; and
- Deep infiltration to a confined sand aquifer underlying the estuarine clay layer.

Infiltration provides a good potential for attenuation of freshwater discharges from the site. It will be important that the final infiltration strategy ensures that the point/s of infiltration is located well away from surface water drains to avoid infiltrated runoff rapidly contributing to surface water flows. It is also considered important that any proposal to discharge into the confined sand aquifer appropriately considers the potential recharge rates to confirm whether the recharge rate or soil infiltration rate controls the rate at which surface runoff generated within the site can be infiltrated.

The capacity of the infiltration areas within the site shall be sufficient to ensure that the design infiltration rates are maintained over the lifecycle of the development and the infiltration rates should be monitored for at least one significant event each year to confirm this.

If you have any questions on the above, please do not hesitate to contact the undersigned.

Yours Faithfully
BMT WBM Pty Ltd



Mark Wainwright
Associate

Appendix B – “Report on Assessment of Proposed Stormwater Infiltration” by Douglas Partners



Douglas Partners

Geotechnics • Environment • Groundwater

Integrated Practical Solutions

REPORT

on

**ASSESSMENT OF PROPOSED STORMWATER
INFILTRATION**

**STAGE 1 – PROPOSED INDUSTRIAL
SUBDIVISION**

TOMAGO ROAD, TOMAGO

Prepared for

ADW JOHNSON PTY LIMITED

on behalf of WEPL Investments

Project 39920.02

DECEMBER 2009



Douglas Partners

Geotechnics • Environment • Groundwater

REPORT

on

ASSESSMENT OF PROPOSED STORMWATER INFILTRATION

STAGE 1 – PROPOSED INDUSTRIAL SUBDIVISION TOMAGO ROAD, TOMAGO

Prepared for

ADW JOHNSON PTY LIMITED

on behalf of WEPL Investments

Project 39920.02

DECEMBER 2009

Douglas Partners Pty Ltd
ABN 75 053 980 117

Box 324
Hunter Region Mail Centre
NSW 2310 Australia

15 Callistemon Close
Warabrook, NEWCASTLE

Phone: 02 4960 9600
Fax: 02 4960 9601
newcastle@douglaspartners.com.au



ASSOCIATION OF CONSULTING
ENGINEERS AUSTRALIA
MEMBER

TABLE OF CONTENTS

	Page
1. INTRODUCTION	1
2. BACKGROUND	2
2.1 Site Definition	2
2.2 Previous Reports	2
2.3 Topography and Geology	3
2.4 Hydrogeology	4
2.5 Surface Infiltration and Mass Balance.....	5
3. PROPOSED STORMWATER MANAGEMENT	6
4. COMMENTS.....	7
4.1 Conceptual Groundwater Model	7
4.2 Groundwater Model	9
4.3 Upstream Swale and Weir Level.....	16
4.4 Distribution of Infiltration Wells.....	17
4.5 Downstream Swale and Wetland Levels.....	17
4.6 Mounding at Recharge Points.....	17
4.7 Detailed Design of Wells and Levels.....	18
5. CONCLUSIONS	19
6. LIMITATIONS	20
REFERENCES	21

ATTACHMENTS

Noted Relating to This Report
Drawing 1 – Groundwater Monitoring Network
Drawing 2 – Preliminary Infiltration Well Locations

PWW:SRJ:sm

Project No: 39920.02

P:\39920.02\Docs\39920.02.doc

4 December 2009

REPORT ON ASSESSMENT OF PROPOSED STORMWATER INFILTRATION
STAGE 1 – PROPOSED INDUSTRIAL SUBDIVISION
TOMAGO ROAD
TOMAGO

1. INTRODUCTION

This report provides a desktop assessment of proposed infiltration of groundwater at the above site for Stage 1 of the proposed development. The assessment was carried out for ADW Johnson Pty Ltd.

It is understood that there is a salt marsh environment downstream of the proposed development site which is sensitive to excessive inflow of fresh water. The proposed development will increase the amount of run-off from the site and measures are required to avoid run-off rapidly contributing to surface water flows downstream of the site. It is proposed to collect the runoff using a system of drainage pipes feeding into shallow swales, which then feed into a constructed wetlands. The swales on the southern parts of the site would include infiltration wells to allow relatively infiltration of water to an underling aquifer. The system has sufficient storage to limit peak flows, and the average flow requiring infiltration will be approximately 100 ML/year.

The purpose of this assessment is to review available data on the soil permeability at the site, provide an assessment of the capability of the site to accept the infiltration, provide recommendations regarding methods and locations of infiltration, provide an indication of the

likely groundwater baseflow from upstream of the site and assess what additional site data needs to be collected to allow detailed design of the infiltration system.

2. BACKGROUND

2.1 Site Definition

The proposed industrial subdivision site is located on the southern side of Tomago Road, Tomago, approximately 8 km south-west of Raymond Terrace, and approximately 12 km north-west of Newcastle. The site details are summarised in Table 1.

Table 1 - Site Details

Address:	197 - 325 Tomago Road, Tomago
Lot/DP:	Lot 161 DP 774440; Lot 1 DP 1003492; Lot 1 DP 597372 and Lot 513 DP585256
Local Government Area:	Port Stephens
Zoning:	IN1 - General Industrial
Total Site Area:	Approximately 116 ha (herein referred to as 'the site')
Stage 1 Site Area (WesTrac):	Approximately 23 ha (herein referred to as 'the Stage 1 site')
Elevation:	0.5 m AHD to 8.5 m AHD
Geological Setting:	Quaternary Alluvium

The Hunter River (North Arm) is located to the south-west and south of the site, varying in distance from about 1.6 km to 2.4 km. Fullerton Cove is located about 2 km east-south-east of the site. The Tomago Sandbeds are situated immediately north of the site and include an extensive water-extraction borefield operated by the Hunter Water Corporation (HWC).

2.2 Previous Reports

The relevant reports in relation to the proposed development and geotechnical / hydrogeological conditions for the site and surrounding areas are summarised in Table 2.

Table 2 - Relevant Reports for the Site and Surrounds

Date	Title	Author
Jul 1990	Prediction of Maximum Water Levels at Tomago Aluminium	Douglas Partners Pty Ltd
1983 -2000	Annual Reviews of Mineral Sands Mining at Tomago	Douglas Partners Pty Ltd
Jul 2001	Preliminary Geotechnical Investigation Proposed Steel Mill and Port Development, Tomago, New South Wales, Australia	Earth & Rock Engineering Pty Ltd
Dec 2001	Stage 2 Geotechnical Investigation Proposed Steel Mill, Tomago, New South Wales, Australia	Earth & Rock Engineering Pty Ltd
Aug 2006	Proposed Industrial Development, 197 - 325 Tomago Road, Tomago, NSW, Preliminary Geotechnical / Due Diligence Assessment	Coffey Geosciences Pty Ltd
Nov 2007	Proposed Westrac Industrial Development - Tomago - Geotechnical Assessment	Coffey Geotechnics Pty Ltd
Jul 2008	Geotechnical Review, Proposed Westrac Facility, Tomago Road, Tomago	Douglas Partners Pty Ltd
Aug 2008	Proposed Industrial Development - Tomago Hydrogeological Investigation	Coffey Geotechnics Pty Ltd
Jul 2009	Major Project Assessment: Redlake Enterprises Industrial Estate	NSW Department of Planning
November 2009	Groundwater Monitoring Plan, Proposed Industrial Subdivision, Tomago Road, Tomago.	Douglas Partners Pty Ltd

DP has not independently confirmed the accuracy or completeness of the above reports where prepared by others and has taken the information presented at face value.

2.3 Topography and Geology

The site topography and regional geology is described in Refs 2 and 3. The main features are:

- The southern part of the site comprises flat water-logged terrain with a typical elevation of 0.5 to 1.0 AHD;
- The northern part of the Stage 1 site is dominated by a low sand dune formation with a maximum elevation of RL 8.5 AHD;
- The site vegetation is mainly grassland and low scrub, with just a few mature trees located on the dune;

- The soil profile comprises alluvial / estuarine sediments (deposited under water), with some aeolian (wind-blown) sand deposits. The resulting upper soil profile consists of very soft to stiff silty clay, clay and sandy clay soils, overlying very loose to medium dense clayey sand;
- The upper soils are underlain by medium dense sand and stiff to hard clay strata. The depth to bedrock has not been established, but exceeds 18 m.

2.4 Hydrogeology

Groundwater was encountered at depths ranging from just at or above ground surface on the southern low lying parts of the site to depths of up to 6 m on the northern parts of the site below the dune formation. Reduced levels of groundwater ranged from about RL 1.6 AHD on the northern parts of the site to about RL 0.6 to 0.75 at the southern boundary of the site, which is at ground surface. To the south of the site the groundwater level generally followed the ground surface levels. It is noted that some observations to the south of the site corresponded to reduced levels slightly below AHD and are these are likely to represent tidal levels at the time of measurement rather than average groundwater levels at the location.

Contours of groundwater head, based on readings taken on 14 September 2007 are presented on Drawing 1 attached and indicate flow to the south-south east with a hydraulic gradient of about 0.0025 to 0.005 on the northern parts of the site and 0.0015 to 0.002 on the southern parts and downstream of the site.

The northern part of the site contains an Aeolian sand dune, overlying Pleistocene inner barrier sand deposits known as the Tomago Sandbeds, both comprising relatively permeable sands. On the southern part of the site the surface soils are relatively low permeability, primarily clayey soils with inter-bedded clayey sand and sandy clay layers. This lower permeability layer is relatively thin on the central parts of the site, typically less than 1 m, and increases in thickness to about 4 to 5 m at the southern boundary of the Stage 1 site.

DP experience with the Tomago Sandbeds indicates a horizontal hydraulic conductivity typically of about 3×10^{-4} m/s. Soil and Rock (Ref 5) undertook a groundwater pumping test on the adjacent site and the results indicated the following:

Upper Clayey Soils

- Horizontal Hydraulic Conductivity 1×10^{-5} m/s to 6×10^{-5} m/s
- Vertical Hydraulic Conductivity 2×10^{-5} m/s

Lower Sand Aquifer

- Horizontal Hydraulic Conductivity 2×10^{-4} m/s to 3×10^{-4} m/s

The thickness of the sand layer on the site typically ranges from about 10 m to 15 m. Bore CBH4, located just to the south of the Stage 1 site indicated sand from 2.7 m depth to at least 13 m depth.

Limited existing groundwater quality data indicates the following:

- The groundwater has high salinity which exceeds drinking water guidelines, with especially high salinity on the southern parts of the site;
- Ammonia concentrations at several locations exceed ANZECC criteria.

2.5 Surface Infiltration and Mass Balance

An assessment of the likely rates of infiltration and runoff on various parts of the site and development of a general water mass balance has been undertaken by BMT WBM (Ref 11) on behalf of the National Parks and Wildlife Service. The report indicated the following:

- Annual mean rainfall of 1110 mm was appropriate for the site;
- 40% to 50% infiltration could be expected on the northern dune parts of the site resulting in a total infiltration of about 50 ML/yr on this part of the site (9.6 ha);

- For lower southern parts of the site a runoff coefficient of 0.5 would be reasonable. This is higher than for typical sites due to the frequently saturated soils, low permeability soils and presence of existing drains;
- A water balance is presented which indicates that post development there will be net increase of about 60 ML/yr due to increased surface runoff and less evapotranspiration because of the site paving. The report concludes that this additional flow will need to be discharged either via surface runoff or infiltration/groundwater recharge;
- The report indicated that “artificial infiltration would provide good potential for attenuation of freshwater from the site”, and “it will be important that the final infiltration strategy ensures the points of infiltration are located well away from surface water to avoid infiltrated water rapidly contributing to surface water flow”.

3. PROPOSED STORMWATER MANAGEMENT

It is understood that the general surface drainage system will comprise the following:

- Constructed Wetland in south-east corner of site. The wetland is understood to be sized to allow storage of runoff from all but extreme events, allowing the runoff to be infiltrated to groundwater at a uniform rate. The floor of the wetland will be at existing surface levels of about RL 0.5 AHD and there overflow weir level is proposed to be set at about RL 1.5. The wetland will collect any water which cannot be accommodated by the surface infiltration system, for discharge during wet weather periods;
- Upstream drainage swale along the northern boundary of the site, flowing to the east and then down the eastern boundary discharging into the downstream swale and constructed wetland. An adjustable height weir structure would be located in the swale about half way down the eastern boundary in order to allow adjustment of the height of ponding of water in the upstream swale;
- Downstream drainage swale along the southern boundary flowing into the constructed wetland in south east corner via an adjustable weir. The swale will have an invert level of about RL 1.0 and will be lined, however include infiltration wells. The height of the weir will be set at about RL 1.5, after which spilling into the constructed wetland will occur.;

- The upstream swale would collect runoff from a limited area of hard standing, to the north of the main buildings. Roof water would be collected into a 2000 m³ rainwater tank. The majority of the hardstand runoff on the southern part of the site would be transferred to the downstream swale via a series of drainage pipes;
- It is proposed to have a series of infiltration wells within the base of the swales, distributed along the lower reaches of both the upstream and downstream swales. The purpose of these wells would be to increase the rate of infiltration and to infiltrate water below the Upper Clay Layer so that the eventual discharge to the surface downstream is spread over an extended area and the groundwater residence time is increased.

4. COMMENTS

4.1 Conceptual Groundwater Model

Based on assessment of the background information on the site, described above, the following conceptual groundwater model has been developed.

- Groundwater flow on the site is to the south and south-east;
- Recharge is from:
 - Groundwater flow from the sand beds to the north of the site;
 - Surface infiltration on northern dunes. Based on experience with other similar sites it is expected that about 40% infiltration of rainfall would be an upper bound, the remainder lost due to evapotranspiration as well as some runoff.
- Discharge is to:
 - Groundwater flow to the south of the site;

- Surface discharge to the low lying areas, including the southern parts of the site, especially near the toe of the existing dune formation. This surface discharge is evident by the presence of a water table at the ground surface. It is considered likely that the reason that the hydraulic gradient on the southern parts of the site is less than that on the northern parts of the site because the low lying surface limits the gradient available on the southern parts of the site. The low gradient means that there is insufficient head to drive the flows coming from the southern part of the site and the excess flow is discharged to the surface.
- The presence of a low permeability confining layer on the southern parts of the site limits the upwards flow to an extent, probably resulting in slightly artesian head in the confined aquifer and leading to the surface discharge being spread over a wider distance downstream than otherwise would occur. Measurement of groundwater heads on site to date have not indicated the presence of significant artesian heads and therefore it is considered that the upper clayey soils provide some, but limited confinement to the lower sand aquifer.
- The low lying parts of the site will be subject to significant evapotranspiration, as water will be available in storage at very shallow depth. The remaining water will be lost due to surface runoff via the collection of shallow surface drains across the area. The relative proportions of runoff and evaporation will vary with rainfall conditions, favouring runoff following rainfall.

Filling of the southern parts of the site and capping of much of the site is expected to have the following effects:

- Reduced infiltration on the northern parts of the site.
- Increased groundwater heads on the southern parts of the development site as the fill material will provide pore water storage, allowing the water to rise above the former ground surface. This will likely result in the surface discharges as a whole being pushed slightly further to the south at the new batter slope which will be located about 200 m further to the south.
- If no infiltration of groundwater is allowed to occur on the site, the overall flows to the south will likely be reduced. The groundwater flow to the south would be unlikely to change significantly as this is already limited by the low surface grades and available hydraulic gradient, however the surface discharge would be slightly reduced.

- If infiltration similar to the existing rates of infiltration were to occur, the surface discharge would be similar to the existing. In this situation the main difference in the overall water mass balance would be that there would be less surface area available for evapotranspiration across the site and this water which formerly evaporated would require alternative management.
- If the infiltration rate on the site is increased relative to the previous condition, then most of the additional flow would eventually discharge to the surface downstream of the development. This is because the existing groundwater flow is already limited by the low lying surface. In the case that the surface clayey soils were highly confining this would result in increased artesian heads and the extra surface discharge being spread over a wide area, similar in extent to the existing extent of surface discharge. If the surface clayey soils are only slightly confining then the additional flow discharge would be to the surface relatively close to the development, similar to the existing discharge situation.

4.2 Groundwater Model

General

The above conceptual model provides a qualitative assessment of groundwater flows and likely impacts on the flow regime from the development. In order to confirm the conceptual model as well as provide an estimate of the relative rates of flows a simple numerical groundwater model was developed.

The model was developed using the computed software SEEP/W and comprised a vertical north-south section through the central to western parts of the site. Due to the variations in estimated hydraulic parameters, in particular the measured values of the permeability of the upper clayey soils, two models were set up, one using lower bound hydraulic properties and the other using higher bound parameters as presented in Table 3 below.

Table 3 – Hydraulic Modelling Parameters

Parameter	Model 1	Model 2
Thickness of Lower Sand Aquifer	10 m	10 m
Lower Sand Aquifer	2×10^{-4} m/s	3×10^{-4} m/s
Upper Clayey Soils	1×10^{-7} m/s	1×10^{-5} m/s
Permeability of Dune Sands	5×10^{-5} m/s	3×10^{-4} m/s

Existing Conditions

The models were then calibrated to match existing conditions in steady state, using annual average flow rates. A rainfall recharge of 40% of the annual 1140 mm/yr (1.5×10^{-5} m/s) was applied to the dunes on the northern parts of the site, based on the lower end of the range of predicted infiltration from BMT WBM report (Ref 11).. A constant head boundary of RL 0.0 was set at about 650 m downstream of the site, in the location where the groundwater contours on Drawing 1 indicated a head of RL 0.0.

The models were then calibrated, by adjusting the upstream flow groundwater flow rates to approximately replicate the measured head distributions from Drawing 1. The results are presented in Figures 1 and 2 below. For calibrated upstream flow rate ranged from 3×10^{-6} m³/s to 7×10^{-6} m³/s. When applied over the 700 m width of the site this relates to an annual flow in the range 66 MI/yr to 150 MI/yr.

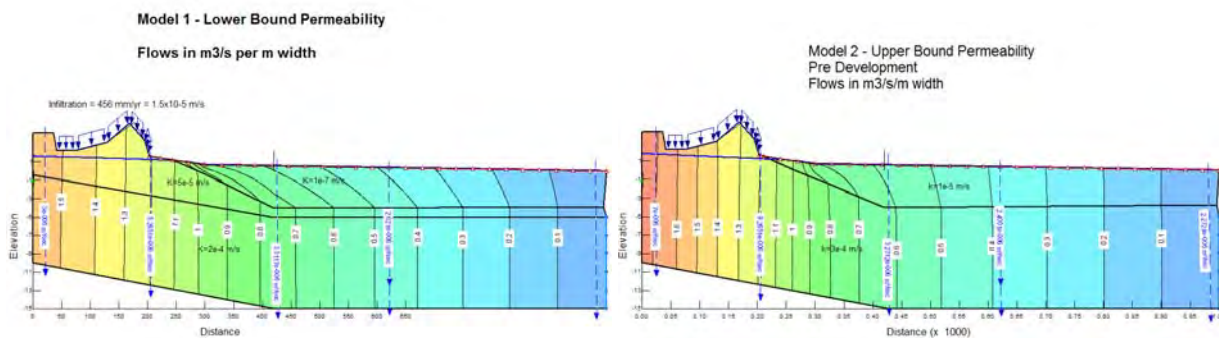

Figures 1 and 2 – Calibration of Existing Conditions

Figures 1 and 2 indicate the following:

- For Model 1 the Upper Clay Layer is confining the flow in the Lower Sand Aquifer, limiting the amount of vertical flow of groundwater up to the surface. There are higher vertical flows near the toe of the existing as the Upper Clay Layer is thinner here;
- For Model 2 there is little confinement of the Lower Sand Aquifer. The majority of upward flow to the surface occurs near the toe of the dune. Although the upstream groundwater flow is greater in Model 2, the downstream flows in both models are similar. This is because the additional upstream flow comes to the surface in Model 2.

Recharge of Lost Rainfall Recharge

The model was then adjusted for the proposed development profile. Rainfall recharge was prevented on the northern part of the site (formerly dunes). The recharge that would have occurred on the northern parts of the site was recharged to Lower Sand Aquifer near the downstream boundary of the Stage 1 development, at a rate of 2.5×10^{-6} m³/s (55 ML/yr over the width of the site).

The resulting head distributions and flow rates are presented in Figures 3 and 4 below.

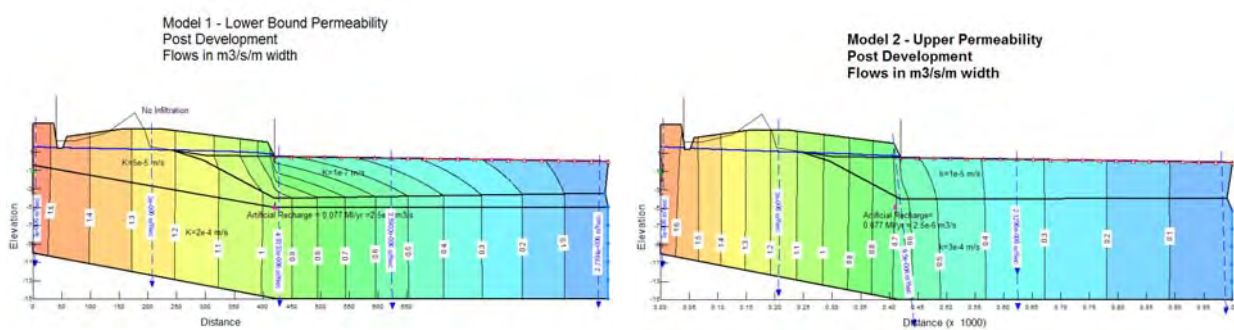

Figures 3 and 4 – Post Development – Artificial Recharge of 55 ML/yr

Figures 3 and 4 indicate the following:

- For Model 1 there is a slightly increased head and flow rates in the Lower Sand Aquifer than for the pre-development case. This is because the water has been infiltrated below the thicker part of the aquifer and therefore surface flows have been reduced. Upstream of the site the heads are very similar to the pre-development case as there is no net increase in flow below the site.
- For Model 2 there is very little change in heads or flows pre and post development.

Additional Recharge Volumes

In order to account for the loss of evapotranspiration across the site the volume of water requiring off-site disposal by infiltration will be greater post-development than the current site infiltration. It is understood that a rate of up to about 100 ML/yr is required to be infiltrated. Therefore the model was adjusted to replicate an additional flow of 110 ML/yr and the results are presented in Figures 5 and 6 below.

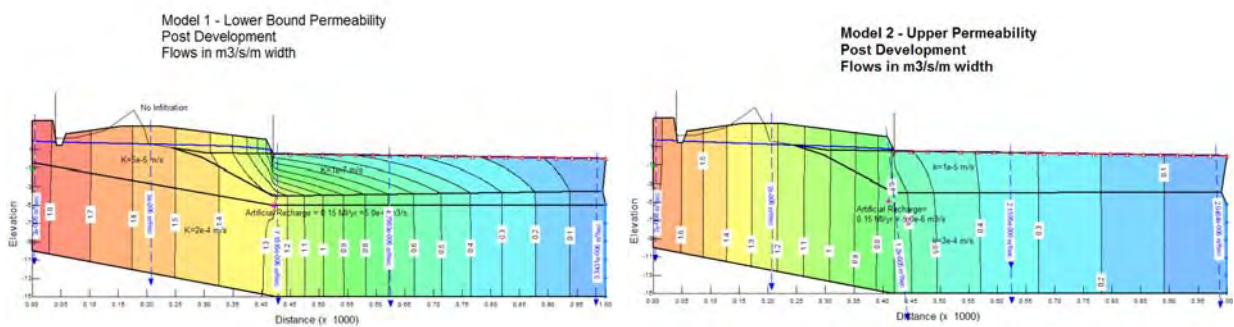

Figures 5 and 6 – Post Development – Artificial Recharge of 110 ML/yr

Figures 5 and 6 indicate the following:

- For Model 1 there is a further increase in head and flow rates in the Lower Sand Aquifer than for the pre development case. Upstream of the site the heads have increased in response to the net increase in flow;

- For Model 2 the heads below and upstream of the site increase in response to the net increase in flow. Downstream of the site there is little change in the heads, as these are controlled by the surface levels, and the additional volumes of flow are discharge to the surface within about 200 m of the toe.

Increased Flow From Upstream

It is noted that the groundwater levels shown on Drawing 1 are unlikely to represent upper bound average levels. In order assess the effect of increased flow from upstream of the site the post-development models with 110 ML/yr artificial recharge were adjusted for double the upstream flow as presented in Figures 7 and 8 below.

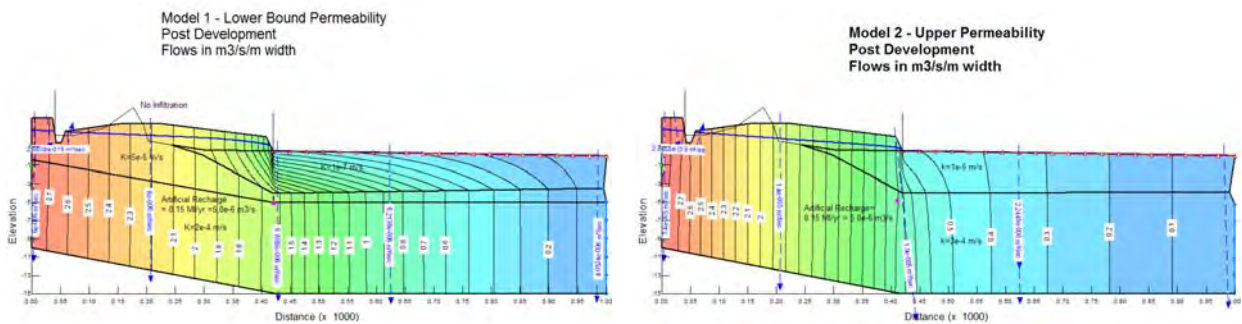

Figures 7 and 8 – Post Development – High Flows

Figures 7 and 8 indicate the following:

- For Model 1 the heads and flows across the site are significantly increased;
- For Model 2 the heads and flows upstream of the site are significantly increased however there is little increase in flows and heads downstream of the site and most of the additional flow comes to the surface.

Upstream Drain

As increased flows from upstream, which could occur after prolonged wet conditions or changes in the HCW borefield pumping, will increase groundwater levels below the site and potentially adversely effect the proposed development it is proposed to install an undrained swale near the northern boundary. For purposes of the modelling, the invert level of the drain was set to RL 1.5, similar to the previously measured groundwater levels. The model was run using doubled upstream flows (as per Figs 7 and 8) and any water extracted from the drain was then re-injected at the downstream side of the site, in additional to 110 ML/yr. This situation replicated the situation where the upstream drains collect regional groundwater from upstream and transfer the water to the downstream swale where it is then available for infiltration. The results are presented in Figures 9 and 10 below.

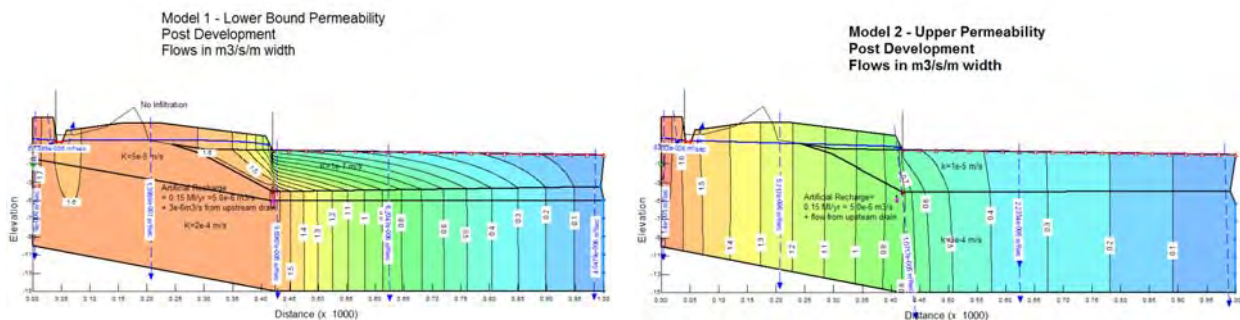

Figures 9 and 10 – Post Development – Upstream Drain with High Flows

Figures 9 and 10 indicate the following:

- For both models the heads below the site are limited to about 1.6 m AHD;
- For both models the heads and flows at the southern boundary and to the southern of the site are similar to the situation with no upstream drain. For Model 1 the head at the southern boundary is about RL 1.5 and for Model 2 it is about RL 0.7.

Summary

In summary the modelling indicated the following:

- For the current situation groundwater discharges to the surface downstream of the site. The area over which the discharge occurs and the time the water stays in the ground as groundwater will depend on the vertical permeability of the Upper Clay Layer. For a range of vertical permeability, the discharge is likely to occur over an area ranging from the existing dune toe to between 200 m and 1000 m south, the larger spread of discharge for soils in the lower end of the expected permeability range;
- Flows from the upstream Tomago Sandbeds are estimated to be in the range 70 to 150 ML/yr across the width of the site, based on the current groundwater level data. The flow will vary with changes in climatic conditions as well as with pumping rates from the Tomago Sand Beds.
- If a volume of water equivalent to the existing estimated rainfall recharge is re-injected to the southern boundary of the site post development, then a very similar groundwater flow regime will result, as there is little net change in groundwater recharge. The existing groundwater recharge is estimated to be about 55 ML/yr over the Stage 1 site;
- If additional water is artificially recharged to the system this will eventually discharge as surface water downstream of the site in a similar distribution to the existing discharges, however pushed a further approximate 200 m downstream as the development footprint will be 200 m further south than the southern edge of the existing dune. That is, for Upper Clay Soils with permeability at the higher end of the expected range, the water would discharge over an area ranging from the downstream boundary to about 200 m south. For lower permeability soils the discharge would be spread over a greater area, ranging from the southern boundary to up to about 1000 m downstream.
- If a drain is installed upstream of the site to limit groundwater levels below the site and then the drained water is re-injected downstream of the site this will reduce the heads below the site, however have little effect on the flows and heads downstream of the site as there is little net change in groundwater flows.

4.3 Upstream Swale and Weir Level

It is noted that the proposed finished level of the site adjacent to the northern drainage swale is 2.7 m AHD. This is about 1.0 to 1.2 m above the measured groundwater levels on site in September 2007, following a relatively dry period. The thickness of the pavement in this area is about 0.8m, which means that the base of the pavement will be about 0.2 to 0.4 m above this groundwater level. A rise in the groundwater level therefore would have potential to lead to saturation of the pavement materials, which may lead to failure of the pavements.

Therefore it is considered that it is preferable to infiltrate groundwater on the southern parts of the site, where localised mounding of the water table would have less potential impact on the development. Lining of the upstream drainage swale has been considered as this will reduce infiltration which would otherwise inevitably occur, however in times of high seasonal groundwater levels an unlined drainage swale would prevent the groundwater levels below the site rising significantly above the invert of the drain or downstream weir level, whichever is higher. It is considered that the risk of elevated groundwater levels from seasonal upstream variations is greater and therefore an unlined drainage swale would provide greater protection in this regard.

It is noted however that the use of an unlined drainage swale on the upstream boundary may lead to drainage of groundwater during seasonally high groundwater levels and this would be transferred to the infiltration areas downslope of the site. In effect the drained water would essentially bypass the site and be re-injected downslope of the site where it would have flowed to anyway.

Determination of an appropriate level for the overflow level in the upstream swale should be based on review of groundwater monitoring data as outlined in the Groundwater Monitoring Plan (Ref 1). Based on the current groundwater information it is expected that the invert level for the drain would need to be at about RL 1.4 to 1.6 AHD, with contingency to raise the level of the down slope weir based on the results of ongoing monitoring.

4.4 Distribution of Infiltration Wells

As discussed above it is recommended that the infiltration wells be distributed across the southern parts of the site. The wells should be located a sufficient distance downstream within the swales of surface discharge points to allow sufficient treatment of nutrients within the swales. Based on the preliminary understanding of the location of discharge points, the location of the infiltration wells is presented on Drawing 2 attached and comprised the following:

- Four wells in downstream swale to the west of the wetland;
- Two wells in upstream swale between the wetland and the weir.

Conceptually, the wells would comprise large diameter steel or concrete pipes, installed to a depth of about 2 m penetration into the lower sand aquifer. Further discussion on detailed design of the wells is given in Section 4.7.

4.5 Downstream Swale and Wetland Levels

The infiltration wells are to be designed to accommodate average flows across the year and not necessarily actual flows during rainfall events. The level of the wells should be uniform to provide relatively uniform infiltration across the length of the site. Base on the proposed invert level of RL 1.0 for the swales it is considered that the swale should be lined to limit shallow infiltration, which is likely to discharge at the very toe of the embankment. For an invert level of RL 1.0 for soil permeability in the lower end of the expected range this may lead to semi-permanent inundation of the swale. For higher soil permeability the swale would be expected to be intermittently inundated, following rainfall. In times of seasonally high groundwater levels spilling at the surface water discharge weir may occur, however high surface discharges would occur naturally during these conditions prior to development.

4.6 Mounding at Recharge Points

Due to the presence of impermeable surface soils on the southern parts of the site it is considered that the groundwater will need to be recharged to the underlying lower sand aquifer.

It is considered that a series of discrete wells/caissons penetrating to the lower sand would be an effective means of infiltrating the water and provided that are spread across the east to west width of the site along the potential for localised mounding of the water table can be reduced.

In order to assess the potential for localised mounding around infiltration points a simple axis-symmetric groundwater model was developed to replicate the steady stage infiltration of groundwater into a single well point. The well was modelled as a 2 m diameter well, penetrating 2 m into a 10 m sand aquifer. An arbitrary fixed head of 0.0 m was set at 50 m radius. A horizontal hydraulic conductivity of 2×10^{-4} m/s was used with a vertical hydraulic conductivity of 10% of the horizontal, at the low bound of the expected parameters. A flow rate of 15 ML/year was applied to the well, based on having five wells points at 100 m intervals. The resulting head distribution at the well point is presented in Figure 11 below and indicates that about 0.5 m of localised mounding would occur around the well in addition to the regional mounding described in Section 4.2 above.

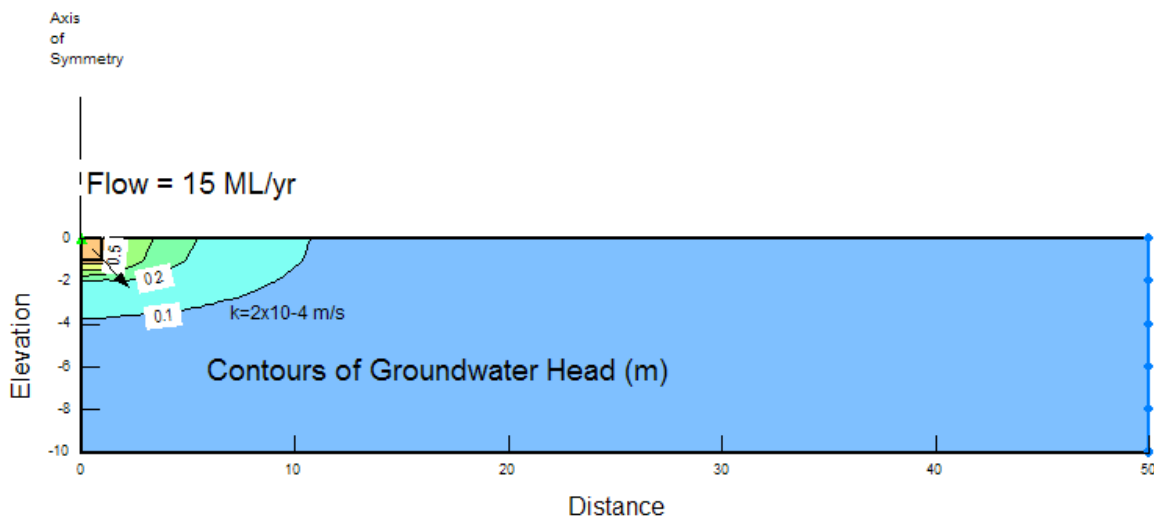

Figure 11- Groundwater Mounding Around Infiltration Well

4.7 Detailed Design of Wells and Levels

It is noted that the above described conceptual design is based on groundwater parameters collected from a desktop review of the site. The actual depth, permeability and thickness of the

lower sand aquifer may vary at specific well locations. In addition the measured groundwater heads are for a single point in time and will vary with climatic variations.

Therefore it is recommended that additional information be collected to allow detailed design of the well points. This should include the following:

- Drilling of three bores along the downstream boundary at proposed well points;
- Installation of groundwater monitoring bores screened within the Lower Sand Aquifer and Upper Clay Layer at each bore;
- Permeability testing of the sand.

It is, however, expected that the wells would either comprise the installation of large diameter steel or concrete pipes, say 1 m or 2 m diameter to a depth of about 2 m penetration into the lower sand aquifer or a nest of smaller diameter conventional groundwater wells. The larger diameter wells would be installed as caissons, by removing material from inside as the wells are lowered into the ground. Conventional wells would be installed using a drilling rig. This would obviate the need to dewater the site, which would otherwise be required for conventional excavation methods. The caissons, if used, would be backfilled with suitable graded gravel and would incorporate a filter system at the surface to reduce potential for clogging of the gravel over time with sediment. Nevertheless, periodic cleaning of the gravel backfill may be required to maintain long term performance.

Final adoption of levels for the swales and weirs, and the associated proportion of site water to be infiltrated, should be based on the results of pre-development groundwater monitoring, as recommended in the Groundwater Monitoring Plan (Ref 1). It is recommended that gauging data from the upstream Tomago Sandbeds also be obtained in order to refine estimates of upstream flow and regional groundwater recharge to confirm the water balance.

5. CONCLUSIONS

In summary it is considered that the proposed surface water management system comprising an upstream drainage swale and downstream infiltration of captured surface water will provide a

mechanism for slowing and spreading off-site water discharges compared to conventional surface water collection and discharge.

Computer modelling has been undertaken to simulate a likely range of hydraulic site conditions, however the actual degree of slowing and spreading of the discharged water will depend on the actual hydraulic characteristics of the site. It is considered that the existing site conditions result in significant surface water discharges to the low lying areas downstream of the site already. The additional flow to the existing system will have an incremental increase on these existing surface water discharges. It is also noted that the groundwater infiltration cannot be expected to prevent all surface water discharges from the constructed wetland, however these would generally occur during more extreme conditions, during which high surface water flows would have also occurred pre development.

It is noted detailed design of the surface water management system is required for the sizing and spacing of infiltration wells and setting of swale and weir levels, which will control the proportion of water infiltrated. It is also recommended that contingency be allowed in the system in the form of adjustable height weirs to allow refinement of the system in response to long term groundwater monitoring, the aim of which should be to set levels to minimise impacts on the existing groundwater regime.

The stormwater management system is likely to require some modification if additional development is added downslope of the Stage 1 development, as additional placement of fill will further alter the hydrogeology.

6. LIMITATIONS

This report is provided for the exclusive use of ADW Johnson Pty Ltd and WEPL Investments Pty Ltd. It should not be used by or relied upon for other projects or purposes on the same or other site or by a third party.

The results provided in the report are considered to be indicative of the sub-surface conditions on the site only to the depths investigated at the specific sampling and/or testing locations, and only at the time the work was carried out. DP's advice may be based on observations, measurements, tests or derived interpretations. The accuracy of the advice provided by DP in

this report is limited by unobserved features and variations in ground conditions across the site in areas between test locations and beyond the site boundaries or by variations with time. The advice may be limited by restrictions in the sampling and testing which was able to be carried out, as well as by the amount of data that could be collected given the project and site constraints. Actual ground conditions and materials behaviour observed or inferred at the test locations may differ from those which may be encountered elsewhere on the site. Should variations in subsurface conditions be encountered, then additional advice should be sought from DP and, if required, amendments made.

This report must be read in conjunction with the attached “Notes Relating to This Report” and any other attached explanatory notes and should be kept in its entirety without separation of individual pages or sections. DP cannot be held responsible for interpretations or conclusions from review by others of this report or test data, which are not otherwise supported by an expressed statement, interpretation, outcome or conclusion stated in this report. In preparing this report DP has necessarily relied upon information provided by the client and/or their agents.

DOUGLAS PARTNERS PTY LTD

Reviewed by:

Will Wright

Principal

Stephen Jones

Principal

REFERENCES

1. Douglas Partners Pty Ltd, “Groundwater Monitoring Plan, Proposed Industrial Subdivision, Tomago Road, Tomago”, Project 39920.02, November 2009.
2. Douglas Partners Pty Ltd (2008), “Report on Geotechnical Review, Proposed Westrac Facility, Tomago Road, Tomago”, Project 39920, 22 July 2008.
3. Coffey Geotechnics (2008), “Proposed Industrial Development - Tomago Hydrogeological Investigation”, Report Ref GEOTSGTE20301AA-AJ, 1 August 2008.

4. Soil & Rock Engineering Pty Ltd, "Preliminary Geotechnical Investigation Proposed Steel Mill and Port Development, Tomago, New South Wales, Australia", Report dcb5264_1_01rep", 13 July 2001.
5. Soil & Rock Engineering Pty Ltd, "Stage 2 Geotechnical Investigation Proposed Steel Mill, Tomago, New South Wales, Australia", Report dcb5264_3_01rep", 28 December 2001.
6. Troedson, A, Hashimoto, RT (eds) "NSW Coastal Quaternary Geology Data Package (on DVD-Rom), New South Wales Department of Primary Industries, Mineral Resources, Geological Survey of New South Wales, Maitland". Prepared for New South Wales Department of Infrastructure, Planning and Natural Resources, Comprehensive Coastal Assessment.
7. Douglas Partners Pty Ltd, "The 1994/95 Annual Review of Mineral Sands Mining at Tomago, NSW", Project 9000-22, 22 December 1995.
8. M J Thom & S R Jones, "Geotechnical and Geophysical Characteristics of an Unconfined Coastal Aquifer at Tomago, NSW, Australia", Proc International Conference on Environmental Management, Geo-Water and Engineering Aspects, Wollongong, February 1993, A A Balkema.
9. Douglas Partners Pty Ltd, "Report on Prediction of Maximum Water Levels at Tomago Aluminium, Tomago", Project 13918, 30 July 1990.
10. Douglas Partners Pty Ltd, "Report on Geotechnical Investigation, Hunter River North Arm, Newcastle, Project 31295, 29 June 2001.
11. BMT WBM, "Proposed Westrac Development, Tomago Road, Tomago", Ref. MEW:L.N1826.001, 11 November 2009.



NOTES RELATING TO THIS REPORT

Introduction

These notes have been provided to amplify the geotechnical report in regard to classification methods, specialist field procedures and certain matters relating to the Discussion and Comments section. Not all, of course, are necessarily relevant to all reports.

Geotechnical reports are based on information gained from limited subsurface test boring and sampling, supplemented by knowledge of local geology and experience. For this reason, they must be regarded as interpretive rather than factual documents, limited to some extent by the scope of information on which they rely.

Description and Classification Methods

The methods of description and classification of soils and rocks used in this report are based on Australian Standard 1726, Geotechnical Site Investigations Code. In general, descriptions cover the following properties - strength or density, colour, structure, soil or rock type and inclusions.

Soil types are described according to the predominating particle size, qualified by the grading of other particles present (eg. sandy clay) on the following bases:

Soil Classification	Particle Size
Clay	less than 0.002 mm
Silt	0.002 to 0.06 mm
Sand	0.06 to 2.00 mm
Gravel	2.00 to 60.00 mm

Cohesive soils are classified on the basis of strength either by laboratory testing or engineering examination. The strength terms are defined as follows.

Classification	Undrained Shear Strength kPa
Very soft	less than 12
Soft	12—25
Firm	25—50
Stiff	50—100
Very stiff	100—200
Hard	Greater than 200

Non-cohesive soils are classified on the basis of relative density, generally from the results of standard penetration tests (SPT) or Dutch cone penetrometer tests (CPT) as below:

Relative Density	SPT "N" Value (blows/300 mm)	CPT Cone Value (q _c — MPa)
Very loose	less than 5	less than 2
Loose	5—10	2—5
Medium dense	10—30	5—15
Dense	30—50	15—25
Very dense	greater than 50	greater than 25

Rock types are classified by their geological names. Where relevant, further information regarding rock classification is given on the following sheet.

Sampling

Sampling is carried out during drilling to allow engineering examination (and laboratory testing where required) of the soil or rock.

Disturbed samples taken during drilling provide information on colour, type, inclusions and, depending upon the degree of disturbance, some information on strength and structure.

Undisturbed samples are taken by pushing a thin-walled sample tube into the soil and withdrawing with a sample of the soil in a relatively undisturbed state. Such samples yield information on structure and strength, and are necessary for laboratory determination of shear strength and compressibility. Undisturbed sampling is generally effective only in cohesive soils.

Details of the type and method of sampling are given in the report.

Drilling Methods.

The following is a brief summary of drilling methods currently adopted by the Company and some comments on their use and application.

Test Pits — these are excavated with a backhoe or a tracked excavator, allowing close examination of the in-situ soils if it is safe to descent into the pit. The depth of penetration is limited to about 3 m for a backhoe and up to 6 m for an excavator. A potential disadvantage is the disturbance caused by the excavation.

Large Diameter Auger (eg. Pengo) — the hole is advanced by a rotating plate or short spiral auger, generally 300 mm or larger in diameter. The cuttings are returned to the surface at intervals (generally of not more than 0.5 m) and are disturbed but usually unchanged in moisture content. Identification of soil strata is generally much more reliable than with continuous spiral flight augers, and is usually supplemented by occasional undisturbed tube sampling.

Continuous Sample Drilling — the hole is advanced by pushing a 100 mm diameter socket into the ground and withdrawing it at intervals to extrude the sample. This is the most reliable method of drilling in soils, since moisture content is unchanged and soil structure, strength, etc. is only marginally affected.

Continuous Spiral Flight Augers — the hole is advanced using 90—115 mm diameter continuous spiral flight augers which are withdrawn at intervals to allow sampling or in-situ testing. This is a relatively economical means of drilling in clays and in sands above the water

table. Samples are returned to the surface, or may be collected after withdrawal of the auger flights, but they are very disturbed and may be contaminated. Information from the drilling (as distinct from specific sampling by SPTs or undisturbed samples) is of relatively lower reliability, due to remoulding, contamination or softening of samples by ground water.

Non-core Rotary Drilling — the hole is advanced by a rotary bit, with water being pumped down the drill rods and returned up the annulus, carrying the drill cuttings. Only major changes in stratification can be determined from the cuttings, together with some information from 'feel' and rate of penetration.

Rotary Mud Drilling — similar to rotary drilling, but using drilling mud as a circulating fluid. The mud tends to mask the cuttings and reliable identification is again only possible from separate intact sampling (eg. from SPT).

Continuous Core Drilling — a continuous core sample is obtained using a diamond-tipped core barrel, usually 50 mm internal diameter. Provided full core recovery is achieved (which is not always possible in very weak rocks and granular soils), this technique provides a very reliable (but relatively expensive) method of investigation.

Standard Penetration Tests

Standard penetration tests (abbreviated as SPT) are used mainly in non-cohesive soils, but occasionally also in cohesive soils as a means of determining density or strength and also of obtaining a relatively undisturbed sample. The test procedure is described in Australian Standard 1289, "Methods of Testing Soils for Engineering Purposes" — Test 6.3.1.

The test is carried out in a borehole by driving a 50 mm diameter split sample tube under the impact of a 63 kg hammer with a free fall of 760 mm. It is normal for the tube to be driven in three successive 150 mm increments and the 'N' value is taken as the number of blows for the last 300 mm. In dense sands, very hard clays or weak rock, the full 450 mm penetration may not be practicable and the test is discontinued.

The test results are reported in the following form.

- In the case where full penetration is obtained with successive blow counts for each 150 mm of say 4, 6 and 7

as 4, 6, 7
 N = 13

- In the case where the test is discontinued short of full penetration, say after 15 blows for the first 150 mm and 30 blows for the next 40 mm

as 15, 30/40 mm.

The results of the tests can be related empirically to the engineering properties of the soil.

Occasionally, the test method is used to obtain samples in 50 mm diameter thin walled sample tubes in clays. In such circumstances, the test results are shown on the borelogs in brackets.

Cone Penetrometer Testing and Interpretation

Cone penetrometer testing (sometimes referred to as Dutch cone — abbreviated as CPT) described in this report has been carried out using an electrical friction cone penetrometer. The test is described in Australian Standard 1289, Test 6.4.1.

In the tests, a 35 mm diameter rod with a cone-tipped end is pushed continuously into the soil, the reaction being provided by a specially designed truck or rig which is fitted with an hydraulic ram system. Measurements are made of the end bearing resistance on the cone and the friction resistance on a separate 130 mm long sleeve, immediately behind the cone. Transducers in the tip of the assembly are connected by electrical wires passing through the centre of the push rods to an amplifier and recorder unit mounted on the control truck.

As penetration occurs (at a rate of approximately 20 mm per second) the information is plotted on a computer screen and at the end of the test is stored on the computer for later plotting of the results.

The information provided on the plotted results comprises: —

- Cone resistance — the actual end bearing force divided by the cross sectional area of the cone — expressed in MPa.
- Sleeve friction — the frictional force on the sleeve divided by the surface area — expressed in kPa.
- Friction ratio — the ratio of sleeve friction to cone resistance, expressed in percent.

There are two scales available for measurement of cone resistance. The lower scale (0—5 MPa) is used in very soft soils where increased sensitivity is required and is shown in the graphs as a dotted line. The main scale (0—50 MPa) is less sensitive and is shown as a full line.

The ratios of the sleeve friction to cone resistance will vary with the type of soil encountered, with higher relative friction in clays than in sands. Friction ratios of 1%—2% are commonly encountered in sands and very soft clays rising to 4%—10% in stiff clays.

In sands, the relationship between cone resistance and SPT value is commonly in the range:—

$$q_c \text{ (MPa)} = (0.4 \text{ to } 0.6) N \text{ (blows per 300 mm)}$$

In clays, the relationship between undrained shear strength and cone resistance is commonly in the range:—

$$q_c = (12 \text{ to } 18) c_u$$

Interpretation of CPT values can also be made to allow estimation of modulus or compressibility values to allow calculation of foundation settlements.

Inferred stratification as shown on the attached reports is assessed from the cone and friction traces and from experience and information from nearby boreholes, etc. This information is presented for general guidance, but must be regarded as being to some extent interpretive. The test method provides a continuous profile of engineering properties, and where precise information on soil classification is required, direct drilling and sampling may be preferable.

Hand Penetrometers

Hand penetrometer tests are carried out by driving a rod into the ground with a falling weight hammer and measuring the blows for successive 150 mm increments of penetration. Normally, there is a depth limitation of 1.2 m but this may be extended in certain conditions by the use of extension rods.

Two relatively similar tests are used.

- Perth sand penetrometer — a 16 mm diameter flat-ended rod is driven with a 9 kg hammer, dropping 600 mm (AS 1289, Test 6.3.3). This test was developed for testing the density of sands (originating in Perth) and is mainly used in granular soils and filling.
- Cone penetrometer (sometimes known as the Scala Penetrometer) — a 16 mm rod with a 20 mm diameter cone end is driven with a 9 kg hammer dropping 510 mm (AS 1289, Test 6.3.2). The test was developed initially for pavement subgrade investigations, and published correlations of the test results with California bearing ratio have been published by various Road Authorities.

Laboratory Testing

Laboratory testing is carried out in accordance with Australian Standard 1289 "Methods of Testing Soil for Engineering Purposes". Details of the test procedure used are given on the individual report forms.

Bore Logs

The bore logs presented herein are an engineering and/or geological interpretation of the subsurface conditions, and their reliability will depend to some extent on frequency of sampling and the method of drilling. Ideally, continuous undisturbed sampling or core drilling will provide the most reliable assessment, but this is not always practicable, or possible to justify on economic grounds. In any case, the boreholes represent only a very small sample of the total subsurface profile.

Interpretation of the information and its application to design and construction should therefore take into account the spacing of boreholes, the frequency of sampling and the possibility of other than 'straight line' variations between the boreholes.

Ground Water

Where ground water levels are measured in boreholes, there are several potential problems;

- In low permeability soils, ground water although present, may enter the hole slowly or perhaps not at all during the time it is left open.
- A localised perched water table may lead to an erroneous indication of the true water table.
- Water table levels will vary from time to time with seasons or recent weather changes. They may not be

the same at the time of construction as are indicated in the report.

- The use of water or mud as a drilling fluid will mask any ground water inflow. Water has to be blown out of the hole and drilling mud must first be washed out of the hole if water observations are to be made.

More reliable measurements can be made by installing standpipes which are read at intervals over several days, or perhaps weeks for low permeability soils. Piezometers, sealed in a particular stratum, may be advisable in low permeability soils or where there may be interference from a perched water table.

Engineering Reports

Engineering reports are prepared by qualified personnel and are based on the information obtained and on current engineering standards of interpretation and analysis. Where the report has been prepared for a specific design proposal (eg. a three storey building), the information and interpretation may not be relevant if the design proposal is changed (eg. to a twenty storey building). If this happens, the Company will be pleased to review the report and the sufficiency of the investigation work.

Every care is taken with the report as it relates to interpretation of subsurface condition, discussion of geotechnical aspects and recommendations or suggestions for design and construction. However, the Company cannot always anticipate or assume responsibility for:

- unexpected variations in ground conditions — the potential for this will depend partly on bore spacing and sampling frequency
- changes in policy or interpretation of policy by statutory authorities
- the actions of contractors responding to commercial pressures.

If these occur, the Company will be pleased to assist with investigation or advice to resolve the matter.

Site Anomalies

In the event that conditions encountered on site during construction appear to vary from those which were expected from the information contained in the report, the Company requests that it immediately be notified. Most problems are much more readily resolved when conditions are exposed than at some later stage, well after the event.

Reproduction of Information for Contractual Purposes

Attention is drawn to the document "Guidelines for the Provision of Geotechnical Information in Tender Documents", published by the Institution of Engineers, Australia. Where information obtained from this investigation is provided for tendering purposes, it is recommended that all information, including the written report and discussion, be made available. In circumstances where the discussion or comments section

is not relevant to the contractual situation, it may be appropriate to prepare a specially edited document. The Company would be pleased to assist in this regard and/or to make additional report copies available for contract purposes at a nominal charge.

Site Inspection

The Company will always be pleased to provide engineering inspection services for geotechnical aspects of work to which this report is related. This could range from a site visit to confirm that conditions exposed are as expected, to full time engineering presence on site.

Copyright © 1998 Douglas Partners Pty Ltd

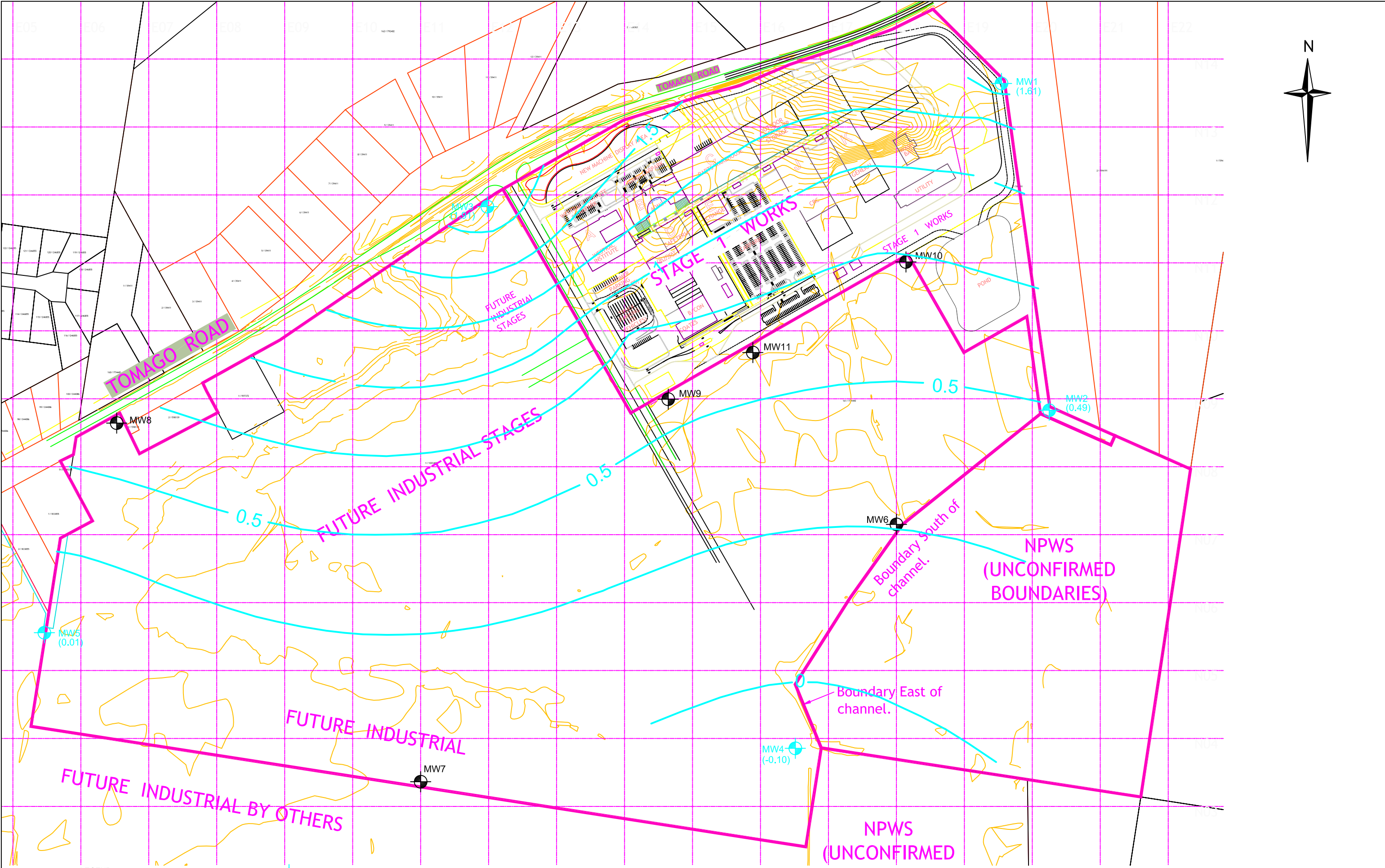

0.5 (0.01) GROUNDWATER CONTOUR
STANDING WATER LEVEL, 14 SEPTEMBER 2007

EXISTING MONITORING WELL LOCATION
PROPOSED MONITORING WELL LOCATION

DRAWING ADAPTED FROM PLAN BY ADW JOHNSON, REF 11886 VERSION B DATED 26.10.09
GROUNDWATER CONTOURS FROM COFFEY GEOTECHNICS PTY LTD, REF GEOTWARA20301AA FIGURE 4

0 100 200m
SCALE 1:5000 (A3 SHEET)



Sydney, Newcastle, Brisbane,
Melbourne, Perth, Wyong,
Campbelltown, Townsville,
Cairns, Wollongong, Darwin

TITLE: GROUNDWATER MONITORING NETWORK
TOMAGO INDUSTRIAL ESTATE
TOMAGO ROAD, TOMAGO

CLIENT: WEPL INVESTMENTS PTY LTD		REF:P:\39920.02\DRAWINGS\39920.02-1	
DRAWN BY: PLH	SCALE: 1:5000	PROJECT No: 39920.02	OFFICE: NEWCASTLE
APPROVED BY:	DATE:	DRAWING No: 1	

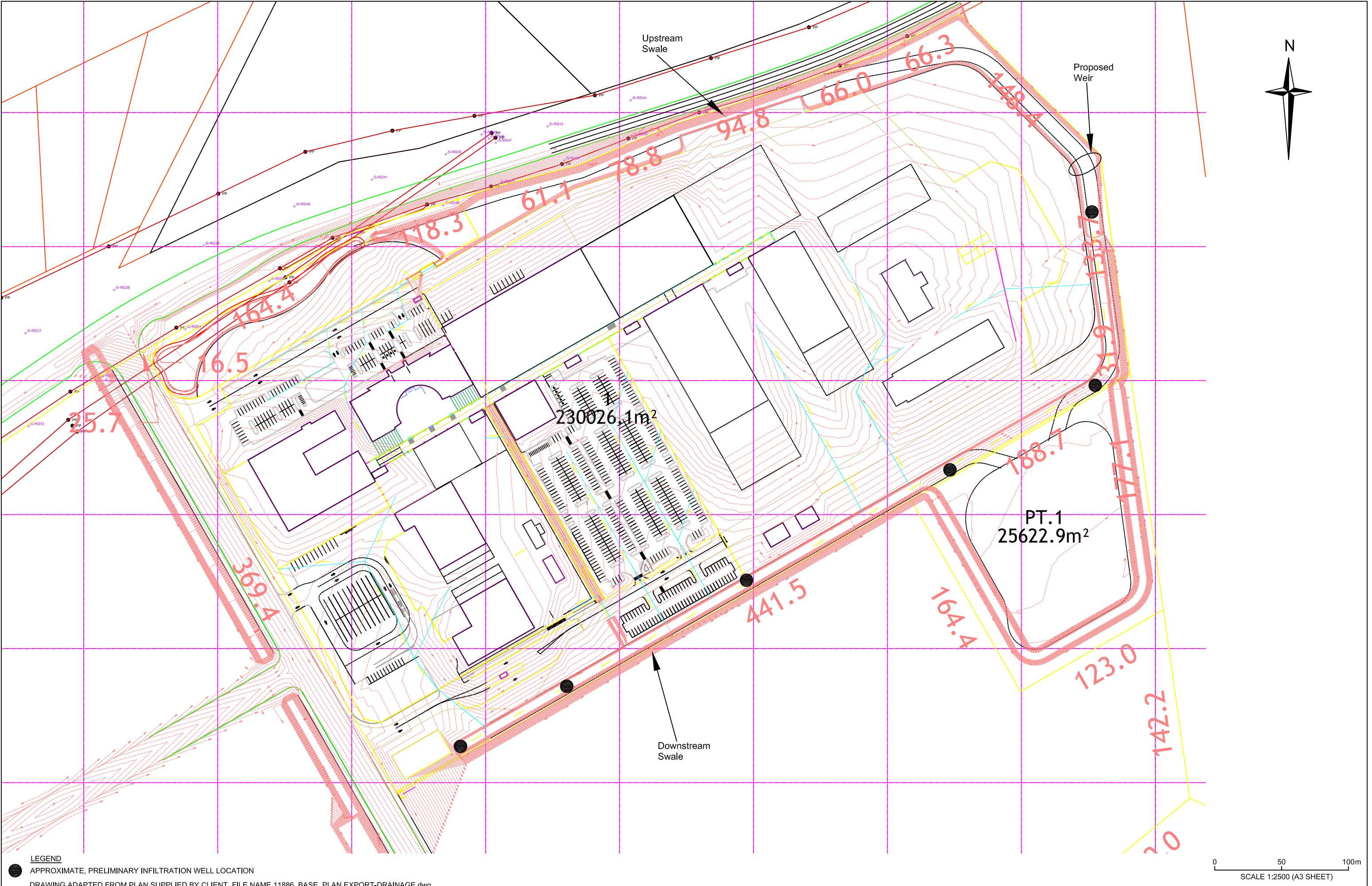

LEGEND
 ● APPROXIMATE, PRELIMINARY INFILTRATION WELL LOCATION
 DRAWING ADAPTED FROM PLAN SUPPLIED BY CLIENT, FILE NAME 11886_BASE_PLAN EXPORT-DRAINAGE.dwg

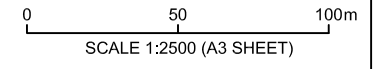

Appendix C – Sediment Basin Calculations

Site: Tomago			
WesTrac facility			
Description		Typical Value	
Catchment Site Area (hectares)	25.2		(minus const. wetland)
Type F/D			
Settling Zone			
Runoff Coefficient, Cv	0.5	0.5	
95th%ile, 5 day Rainfall Event	76.7		Table 6.3a, pg 6-24
Settling Zone Volume	9664		m3
Sediment Zone			
Disturbed site Area (hectares)	25.2		
Rainfall Erosivity Factor, R	2500		Appendix B, Newc B-11
Soil Erodibility Factor, K	0.059		Appendix A, Figure A3
Slope Length Gradient Factor, LS	0.27		Table A1, pg A-9
Erosion Control Practice Factor, P	1.3	1.3	Table A2, pg A-11
Cover Factor, C	1	1	Figure A5, pg A-12
Sediment Zone Volume	171		m3
Total Storage required			
Settling + Sediment	9835		m3

Appendix D – Inspection Checklist

Stormwater Inspection Checklist for WesTrac Facility at Tomago

Item	Work Required?	Photo Taken?	Comment	Action Taken/Date Taken	Follow up Required
Southern Boundary Swale					
Condition of invert and batters					
Condition of bio-retention/gravel					
Notes			Check sediment build up, rubbish		
Basin					
Condition of embankment					
Condition of pipe grate					
Condition of v notch plate					
Condition of spillway and energy dissipation					
Condition of Water Level Control Structure					
Condition of Monitoring Equipment					
Common Boundary with adjoining Neighbour					
Basin outlet drain along Eastern Boundary standing water level Condition 12A(c)					
Notes			Check for erosion, sediment build up, rubbish, weeds, tree/shrub growth on embankment		
Machine Test & Demonstration Area					
Sediment Fence					
Sprinkler					
Grate for vehicles					
Notes			Check for erosion, dust, rubbish		

Appendix E – Addendum No.1 dated Feb 2011



Our Ref:SD:11886

N:\11886\Admin\Letters\Authorities\Feb11,L01,DoP (Addendum No. 1 - SWMP-RevB).doc

1 February 2011

**RE: ADDENDUM NO. 1 - ADDITION OF ASSOCIATED REGRADE AREAS TO STAGE 1
ENVIRONMENTAL MANAGEMENT PLAN – SOIL & WATER MANAGEMENT PLAN (MP07_0086)
TOMAGO ROAD, TOMAGO**

Figures 2 & 7 are replaced with the attached plans to include the associated regrade areas.

Executive Summary, Page ii - ADW Johnson Pty Limited has been engaged by WEPL Investments Pty Ltd to complete the Soil and Water Management Report (SWMP) for the proposed WesTrac facility and associated regrade works being Stage 1 of the approved Part 3A project, Project No. 07_0086 at Tomago Road, Tomago.

Section 1.0 Introduction & Compliance Requirements, Page 1 - ADW Johnson Pty Limited has been engaged by WEPL Investments Pty Ltd to complete the stormwater management strategy, design and reporting for the proposed WesTrac facility and associated regrade works being Stage 1 of the approved Part 3A project, Project No. 07_0086 at Tomago Road, Tomago.

Section 2.0 Site Description, Page 13 - The land is located on the northern floodplain of the Hunter River on the southern side of Tomago Road, Tomago. Topographically, the site comprises a low dunal formation up to 8.5m AHD across the northern half of the site and a flat, low lying alluvial plain at an elevation of 0.5-1.5m AHD across the southern half of the site. West and adjacent is a secondary lower dunal formation up to 4m AHD to be used for associated regrade works. South and adjacent is floodplain that will also be used for associated regrade works. These comprise distinctly different soil types and conditions, being sand and waterlogged clays respectively. Refer to Figure 2.

Yours faithfully
ADW Johnson Pty Ltd – (Hunter Office)

A handwritten signature in black ink, appearing to read 'Scott Day', written over a faint grid background.

SCOTT DAY
ENVIRONMENTAL ENGINEER

ADW JOHNSON PTY LIMITED

ABN 62 129 445 398

central coast
2 bounty close, tuggerah nsw 2259
po box 3717, tuggerah nsw 2259
phone. 02 4305 4300
fax. 02 4305 4399
video conf. 02 4305 4374
email. coast@adwjohnson.com.au

www.adwjohnson.com.au

hunter region
7/335 hillsborough road, warners bay nsw 2282
phone. 02 4978 5100
fax. 02 4978 5199
video conf. 02 4954 3948
email. hunter@adwjohnson.com.au

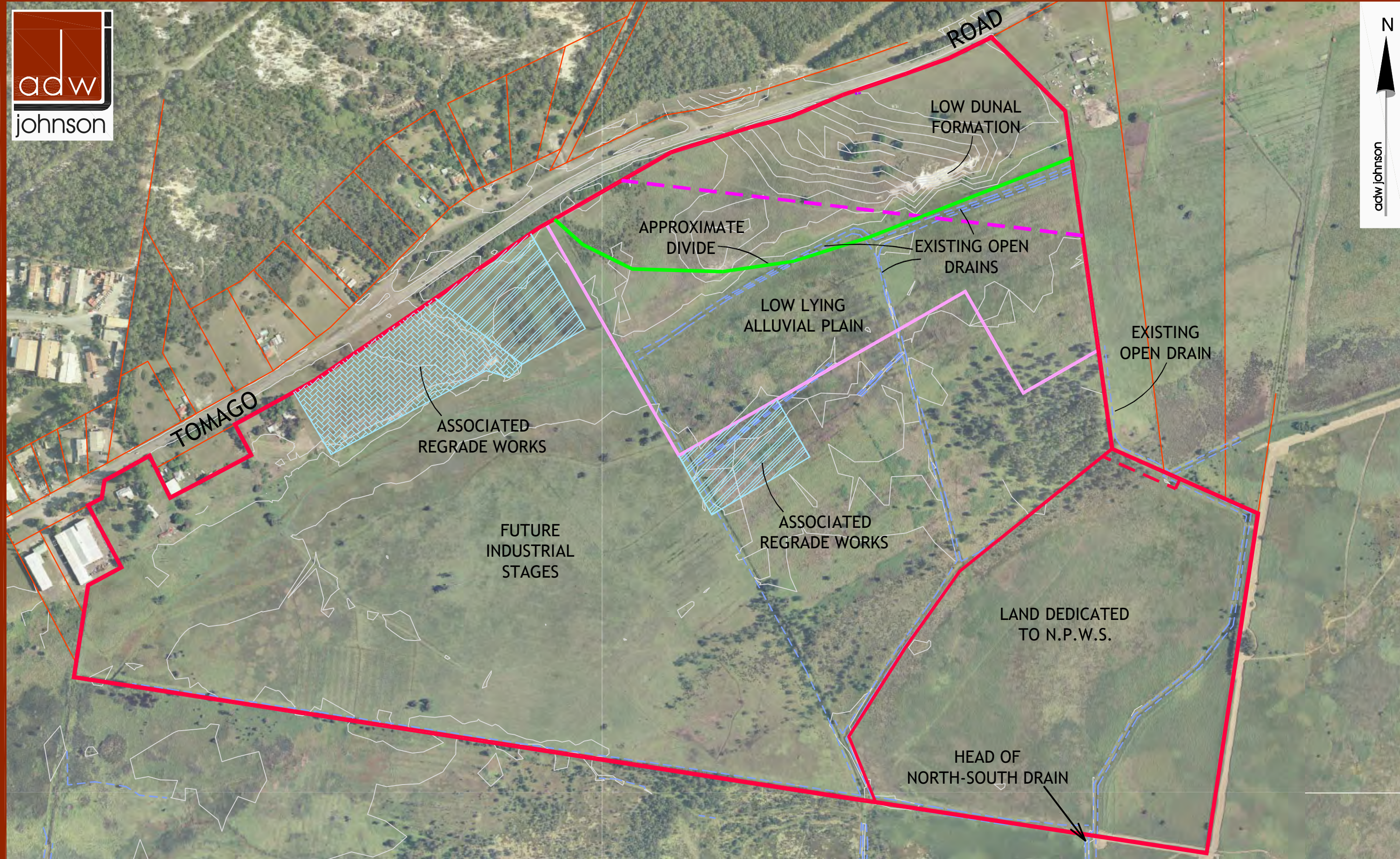

"COPYRIGHT NOTICE"
THIS PLAN AND THE INFORMATION IT CONTAINS ARE COPYRIGHT AND REMAIN THE PROPERTY OF ADW Johnson Pty Ltd. ADW Johnson Pty Ltd GRANTS TO THE CLIENT NAMED ON THIS PLAN A LICENCE TO USE THE INFORMATION HEREON FOR THE PURPOSE FOR WHICH WE WERE ENGAGED TO PERFORM THE WORK. USE OF THE PLAN AND INFORMATION IT CONTAINS FOR ANY OTHER PURPOSE IS NOT PERMITTED UNLESS PRIOR WRITTEN APPROVAL HAS BEEN OBTAINED FROM ADW Johnson Pty Ltd.

- SITE BOUNDARY
- SURROUNDING BOUNDARIES
- - - OPEN DRAIN
- WESTRAC BOUNDARY (STAGE 1)
- - - HWC SPECIAL AREA

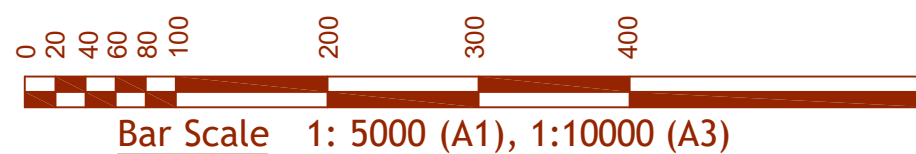
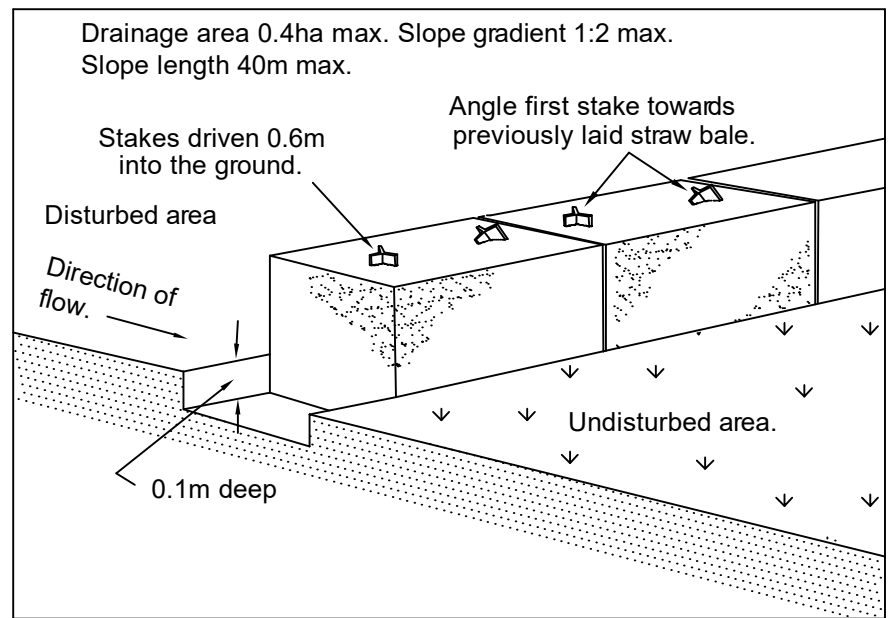
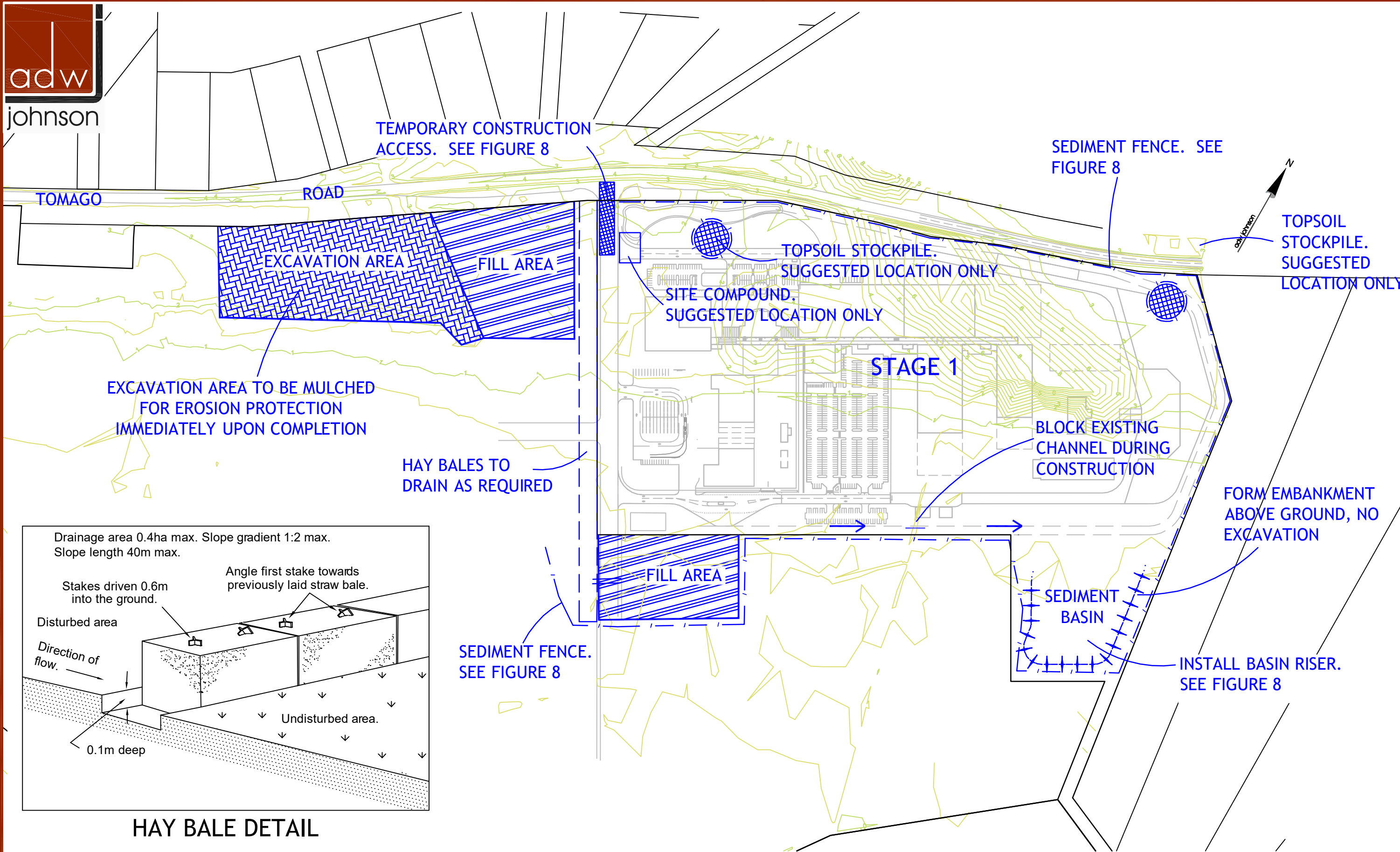

FIGURE 2
EXISTING SITE



EXCAVATION AND FILL AREAS ARE ASSOCIATED WITH STAGE 1 WORKS



FIGURE 7
SOIL AND WATER MANAGEMENT

"COPYRIGHT NOTICE"
THIS PLAN AND THE INFORMATION IT CONTAINS ARE COPYRIGHT AND REMAIN THE PROPERTY OF ADW Johnson Pty Ltd. ADW Johnson Pty Ltd GRANTS TO THE CLIENT NAMED ON THIS PLAN A LICENCE TO USE THE INFORMATION HEREON FOR THE PURPOSE FOR WHICH WE WERE ENGAGED TO PERFORM THE WORK. USE OF THE PLAN AND INFORMATION IT CONTAINS FOR ANY OTHER PURPOSE IS NOT PERMITTED UNLESS PRIOR WRITTEN APPROVAL HAS BEEN OBTAINED FROM ADW Johnson Pty Ltd.

Appendix F – “Report on Revised Surface Water Monitoring Procedure” by Douglas Partners

**Report on Revised Surface Water
Monitoring Procedure**

Stage 1 Northbank Enterprise Hub

**Lot 212 and Part Lot 211 DP 1174939,
Westrac Drive, Tomago, NSW**

**Prepared for Northbank Enterprise Hub
Pty Ltd**

Project 39920.09

26 November 2025

Document History

Details

Project No.	39920.09
Document Title	Revised Surface Water Monitoring Procedure
Site Address	Stage 1 Northbank Enterprise Hub Lot 212 and Part Lot 211 DP 1174939, Westrac Drive, Tomago, NSW
Report Prepared For	Northbank Enterprise Hub Pty Ltd
Filename	39920.09.R.019.Rev2

Status and Review

Status	Prepared by	Reviewed by	Date issued
Revision 0	Dana Wilson	Will Wright	28 February 2025
Revision 1	Dana Wilson	Will Wright	3 March 2025
Revision 2	Dana Wilson	Will Wright	26 November 2025

Distribution of Copies

Status	Issued to
Revision 0	Northbank Enterprise Hub Pty Ltd
Revision 1	Northbank Enterprise Hub Pty Ltd
Revision 2	Northbank Enterprise Hub Pty Ltd

The undersigned, on behalf of Douglas Partners Pty Ltd, confirm that this document and all attached drawings, logs and test results have been checked and reviewed for errors, omissions and inaccuracies.

Signature

Date

Author	<i>Dana Wilson</i>	26 November 2025
Reviewer	<i>P W Wright</i>	26 November 2025

Table of Contents

		Page No
1.	Introduction.....	1
2.	Surface water monitoring procedure	1
2.1	Monitoring summary.....	1
2.2	Surface water monitoring network.....	3
2.3	Surface water monitoring parameters and test frequency	4
2.4	Sampling and testing protocols.....	6
2.5	Surface water quality assessment criteria	7
2.6	Assessment of surface water and contingency measures	8
2.7	Reporting.....	10
2.8	Review and continuous improvement of the monitoring program and effectiveness	10
2.9	Summary of improvements and modification to surface water monitoring	11
3.	References	11
4.	Limitations	12

Appendix 1: Drawing 5 – Groundwater and Surface Water Monitoring Locations

Appendix 2: About This Report

Appendix 3: Table E3: Surface Water Quality Assessment Criteria

Appendix 4: Groundwater Quality Plots
Surface Water Quality Plots

Revised Surface Water Monitoring Procedure

Stage 1 Northbank Enterprise Hub

Lot 212 and Part Lot 211 DP 1174939, Westrac Drive, Tomago, NSW

1. Introduction

This revised surface water monitoring procedure has been prepared by Douglas Partners Pty Ltd (Douglas) for Stage 1 of the Northbank Enterprise Hub (NEH) at Lot 212 and Part Lot 211 DP 1174939, Westrac Drive, Tomago, NSW (the site). The investigation was commissioned by Bryant Stokes of Northbank Enterprise Hub Pty Ltd and was undertaken in line with Douglas' proposal 39920.09.P.011.Rev0 dated 7 November 2024.

Stage 1 and future stages 2 and 3 of the industrial development, as defined on Drawing 1 in Appendix 1, were approved under Environment Protection and Biodiversity Conservation Act (EPBC) approval 2007/3343. An initial Soil and Water Management Plan (SWMP) prepared by ADW Johnson Pty Ltd (ADWJ, 2011) for surface water management and related issues for the Stage 1 development and was approved by a delegate of the Minister. The SWMP included a surface water monitoring program which was developed from Douglas' initial Groundwater Monitoring Program (GMP) (Douglas, 2010) which was also prepared for the Stage 1 development,

This document presents a revised surface water monitoring procedure for inclusion in a revised Stage 1 SWMP to be prepared by ADWJ and to be submitted for approval.

The monitoring locations are based on continuation of the annual monitoring program, monitoring locations and testing program. A revised Groundwater Monitoring Plan (GMP) has been prepared by Douglas under separate cover (Douglas, 2025).

This report must be read in conjunction with all appendices including the notes provided in Appendix 2.

2. Surface water monitoring procedure

2.1 Monitoring summary

The surface water monitoring program is summarised in Table 1 with the nominated monitoring locations shown on Drawing 5 in Appendix 1 and discussed in the following sections.

The revised monitoring program focusses on 'ongoing monitoring' as defined in the initial SWMP (ADWJ, 2011) given that Stage 1 construction is complete.

The initial SWMP included monitoring for Category 1 (field parameters, pH, EC, TSS) and Category 2 parameters (cations and anions) at three monthly (quarterly) and 6 monthly (biannual) intervals and proposed periodic review of the plan with the potential to relax these requirements based on the results of the ongoing monitoring.

The review of surface water monitoring results by Douglas indicated that the monitoring at an annual interval provided a reasonable characterisation of annual site water quality. No adverse trends were identified for the annual monitoring data available. The Category 1 and 2 parameters are considered to be of limited value on their own for standalone monitoring events as they assist to inform general conditions and interpretation of laboratory testing data, rather than identifying potential impacts due to site practices.

Continuation of monitoring at an annual frequency is proposed by the consent holder. The Category 3 parameters have been combined with the former Category 2 parameters to provide a comprehensive laboratory suite.

Table 1: Summary of monitoring program for Stage 1

Parameters	Ongoing monitoring (Stage 1 complete)
Surface water locations to be monitored	SW1 to SW4 Locations SW3a and Graham Drive are alternates when SW3 is dry
Category 1 (field parameters)	12 Monthly (April or May)
Category 2 (laboratory parameters)	12 Monthly (April or May)
Notification of exceedances	As per Table 2 in Section 2.6 for actions prompted by monitoring results
Reporting	12 Monthly
Monitoring program review	12 Monthly in routine monitoring reports
	Formal review and update five yearly as per Section 2.8

It is understood that development of each future stage, will require preparation of stage specific monitoring plans for approval by the Minister. Stage 3 development and associated monitoring and management plans were approved by the Minister on 12 July 2024.

Re-establishment of quarterly (three monthly) monitoring would be recommended during construction of Stage 2 or adjacent and upgradient properties which have the potential to impact the Stage 1 site.

The standards in Table 2 have been identified for surface water monitoring.

Table 2: Summary of relevant standards

Item	Reference Standard
Surface water quality sampling procedures	<ul style="list-style-type: none"> Monitoring sampling, testing and assessment of surface water shall be undertaken by appropriately qualified hydrogeologists or environmental scientists. NEPC. (2013). <i>National Environment Protection (Assessment of Site Contamination) Measure 1999 (as amended 2013) [NEPM]</i>. Australian Government Publishing Services Canberra: National Environment Protection Council. Australian/New Zealand Standard (AS/NZS) 5667.1:1998 Water quality: sampling part 1 – guidance on the design of sampling programs, sampling techniques and the preservation and handling of samples; AS/NZS 5667.4 Water quality: sampling guidance on sampling from lakes, natural and manmade; AS/NZS 5667.6 Water quality: sampling guidance on sampling of rivers and streams.
Laboratory testing	<ul style="list-style-type: none"> Environment Protection Authority Approved methods for the sampling and analysis of water pollutants in NSW, 2022. NATA accredited laboratory to test methods.
Review of surface water quality and hydrogeological trends	<ul style="list-style-type: none"> Appropriately qualified hydrogeologists or environmental scientists.

2.2 Surface water monitoring network

Surface water quality for the current Stage 1 development should be monitored using the client nominated network of four surface water locations as shown on Drawing 5 in Appendix 1.

The client nominated surface water locations are as follows:

- Site basin – SW1;
- Cross-gradient – SW2;
- Upgradient – SW3, SW4.
- Locations SW3a and Graham Drive are alternates when SW3 is dry.

SW1 and SW2 have been subject to long term monitoring since 2013. Other locations were added to the program from 2015 and 2017.

2.3 **Surface water monitoring parameters and test frequency**

The surface water quality parameters to be monitored capture a range of general water quality indicators. A list of potential contaminant of concern (PCoC) for groundwater was devised by Douglas in the revised GMP (Douglas, 2025) based on the results of previous monitoring, current and continued future use for commercial / industrial activities. The surface water testing and frequency is generally consistent with the recommended groundwater program.

Table 3: Summary of surface water field, laboratory testing and frequency

Locations to be monitored	As per Section 2.2
Frequency of monitoring	12 monthly (except during any construction phases as per Table 1 in Section 2.1)
Category 1 Parameters (Field parameters)	<ul style="list-style-type: none"> • Temperature (T) • pH • Electrical Conductivity (EC) • Dissolved oxygen (DO); • Oxidation-reduction potential (ORP) • Turbidity.
Category 2 Parameters (laboratory)	<ul style="list-style-type: none"> • Total Suspended Solids (TSS) • Cations: <ul style="list-style-type: none"> – Calcium (Ca) – Potassium (K) – Sodium (Na) – Magnesium (Mg) • Anions as general water quality indicators <ul style="list-style-type: none"> – Chloride (Cl) – Sulphate (SO₄) – Bicarbonate (HCO₃⁻) – Carbonate (CO₃²⁻) – Total alkalinity – Fluoride (F) • Nutrients: <ul style="list-style-type: none"> – Nitrate (NO₃) – Nitrite (NO₂) – Ammonia (NH₃) – Total Kjeldahl Nitrogen (TKN) – Total Phosphorous (PO₄⁻) • Heavy metals (total, non filtered): <ul style="list-style-type: none"> – Aluminium (Al) – Arsenic (As) – Cadmium (Cd) – Chromium (Cr) – Copper (Cu) – Iron (Fe) – Lead (Pb) – Manganese (Mn) – Mercury (Hg) – Molybdenum (Mo) – Nickel (Ni) – Zinc (Zn) • Heavy metals (dissolved, field filtered): <ul style="list-style-type: none"> – Aluminium (Al) – Arsenic (As) – Cadmium (Cd) – Chromium (Cr) – Copper (Cu) – Iron (Fe) – Lead (Pb) – Manganese (Mn) – Mercury (Hg) – Molybdenum (Mo) – Nickel (Ni) – Zinc (Zn)
	<ul style="list-style-type: none"> • Total recoverable hydrocarbons (TRH) • Polycyclic aromatic hydrocarbons (PAH) • Benzene, toluene, ethyl benzene, xylene (BTEX) • Polychlorinated biphenyl (PCB) • Phenols • Per- and polyfluoroalkyl substances (PFAS)

If the results of field observations or initial laboratory testing indicate exceedances of the adopted criteria or results which warrant further consideration, additional laboratory testing and further review may be required such as:

- Hydrocarbon detection:
 - o Speciation testing via the total petroleum hydrocarbon (TPH) silica gel clean up method to assess for the presence of petroleum and/or non-petroleum based hydrocarbons;
 - o Review of laboratory chromatograms for assessment of the possible hydrocarbon source/type.
- Metals:
 - o Speciation testing to further assess the significance of the result e.g. Cr (III), Cr (VI);
- Re-testing of the sample where elevated suspended solids are present;
- Comparison of total and dissolved metals where elevated suspended solids may have influenced the result.

The assessment criteria are shown on Table E3 in Appendix 3 and discussed in Section 2.5. It is noted that not all parameters have an assigned criterion.

2.4 Sampling and testing protocols

Surface water should be sampled using a telescopic pole and decontaminated sample container which is consistent with the most recent monitoring and is in line with standard industry practice.

The sampling methods should include:

- A new pair of disposable nitrile gloves are worn at each sample site to minimise potential for cross-contamination;
- Field testing of surface water for T, pH, EC, DO, ORP and turbidity;
- Filtering and preservation of samples, where required (analyte specific);
- Placement of the sample jars into a cooled, insulated and sealed container for transport to the laboratory; and
- Chain of custody documentation;
- Duplicate samples on at least 10% of samples or one per monitoring event;
- Reporting (NSW EPA, 2020).

Laboratory testing should be undertaken at a NATA-accredited chemical laboratory to LORs which allow for comparison against the assessment criteria, where possible. The assessment criteria are shown on Table E3 in Appendix 3.

2.5 Surface water quality assessment criteria

The ANZG (2018; 2023) guidelines recommend the use of site baseline data and relevant default guideline values (DGVs) to derive site-specific trigger levels, particularly where background concentrations naturally exceed DGVs. In this approach, *the natural range of values for key indicators at reference sites is used to provide a suitable baseline for comparison against values derived from similar aquatic ecosystems* (ANZG, 2023).

ANZG (2023) recommends data collected over 2 years of monthly sampling as a sufficient data set to indicate ecosystem variability and therefore suitable for guideline value derivation. Douglas notes that this would include downstream monitoring to assess the receiving environment.

In the absence of such a detailed surface water data set, the DGVs are considered most appropriate for assessment of surface water. It is noted that there are no identified downgradient drinking water users, therefore only ecological receptors have been considered.

Groundwater and surface water flowing towards the site from the Tomago Sandbeds is low in salinity and is considered to be a fresh water environment. The downgradient receiving environment and groundwater dependent ecosystems (GDEs) are considered to be an estuarine environment, receiving saline/marine tidal surface water flows which inundate the low-lying land areas of the Ramsar wetlands.

In the absence of estuarine criteria, ANZG (2018) marine water guidelines are considered appropriate in the development of water quality objectives, and considering the most sensitive receptor (wetlands).

A level of species protection (LOSP) of 95% has been considered in the review of ANZG DGVs. This level is consistent with the previous consent approvals and assessment of water quality to date (i.e. 2010-2025) and applies to 'slightly to moderately disturbed systems. As noted in the revised GMP (Douglas, 2025), the downstream wetland is subject to tidal inflows from the Hunter River which contribute about 90% of the overall flux. Hunter River stormwater quality monitoring by Office of Environment and Heritage in 2015 indicated elevated contaminants from industrial, agricultural and urban discharges (Swanson, et al 2017). In periods of rainfall, the river quality has exceeded the 80% LOSP criteria. Adopting a LOSP higher than 95% is therefore not considered appropriate.

The assessment criteria for PFAS has considered the HEPA (2020) 95% LOSP. It is noted that the 99% LOSP is notably stringent and below the current LOR for most laboratories. The limited testing to date has indicated some surface waters, including upgradient locations, have identified PFAS above the 99% LOSP criteria, present at concentrations indicative of the urban environment. Therefore the 95% LOSP is considered appropriate.

It is also noted that an exceedance of a guideline value at a surface water monitoring location upstream of the receptors does not imply exceedance at the receptors, as fate and transport mechanisms can result in significant dilution, retardation and attenuation of solutes and this should be considered in the assessment of the significance of monitoring results.

It is also recognised that groundwater and surface water (as emanated groundwater) in the region has background levels of various parameters, in particular metals, with concentrations higher than the ANZG (2018) criteria.

In summary, the relevant criteria for surface water have been adopted as follows:

- The ANZG (2018) marine water criteria at 95% LOSP is adopted as the DGV;
- Where no criteria or site based data exists, the trigger level has generally been adopted as the laboratory limit of reporting (LOR) for parameters which are not expected to be naturally occurring in the environment (e.g. hydrocarbons etc);
- For PFAS, the trigger level is based on HEPA (2020) 95% LOSP;
- For other general water quality indicator parameters (e.g. hardness, alkalinity), a trigger value has not been set.

The criteria for each analyte are provided in Table E3 in Appendix 3.

The actions for assessing the data, in particular where results are above the criteria, are summarised in Table 4 in Section 2.6.

It is noted that it may be appropriate to undertake further review of the adopted DGVs:

- As guidelines are updated;
- If it is deemed necessary to undertake site-specific modifications to criteria that can be made (e.g. adjustment for aquatic ecological DGVs based on hardness, pH, dissolved organic carbon, salinity etc).

2.6 **Assessment of surface water and contingency measures**

It is considered that the historical surface water data set could be used to indicate when monitored values are above average background levels, prompting further review and closer scrutiny. Exceedance of the DGV trigger levels would prompt further assessment. This procedure is summarised in Table 4 .

Table 4: Actions prompted by monitoring results

Event	Action
<p>Result exceed trigger level based on DGVs (Table E3 in Appendix 3)</p>	<ul style="list-style-type: none"> • Assessment of the significance of the exceedance including, but not limited to: <ul style="list-style-type: none"> ○ Comparison with previous/historic site surface water monitoring data as shown on concentration vs time plots (i.e. is the result within data range for the historic data set for the surface water location and/or all surface water monitoring locations); ○ Review the basis for the trigger level criteria (i.e. reliability of the guideline value); ○ Review of surface water / groundwater flow directions (i.e. representative of surface water up-gradient, within site, and/or downgradient) and risk to receptors; ○ Review surface water flow volumes entering basin and preceding climatic conditions for possible influence (e.g. rainfall effects prior to event, abnormally dry/wet conditions etc); ○ Assess possible source of impacts. • Undertake additional speciation laboratory testing, if suitable (e.g. hydrocarbons or metals). <ul style="list-style-type: none"> • If the result is considered potentially significant in terms of potential impacts (on site or downgradient), undertake additional sampling at the relevant location(s) and analysis for parameter(s) concerned. A timeline of up to 28 days from confirmation of the initial results should be considered as a practicable timeframe for re-sampling. • Advise Stage 1 lessee to review procedures, maintenance and incident records and notify consultant of relevant findings. • If the re-sampled result confirms the initial value, note the occurrence in the in monitoring report for additional review at next annual monitoring event. Additional actions would be prompted by further consecutive events as below. • If the re-sampled result is within the trigger level, suggesting the prior result was spurious or an aberration, then a note is to be made of the re-test in annual reporting.
<p>Three consecutive results exceed the trigger level (including re-testing, if undertaken) and/or in the event two consecutive annual sample results exceed the trigger value (Table E3 in Appendix 3)</p>	<ul style="list-style-type: none"> • Investigate the possibility of adverse changes to the surface water quality/flow regime and/or contaminant plume; • Implement appropriate actions to investigate and/or mitigate contamination risks. Actions may include: <ul style="list-style-type: none"> ○ A detailed site inspection of the site and adjacent sites to identify possible source(s); ○ The possible need to temporarily increase the frequency of monitoring until results have returned to below the trigger levels or within the historical range; ○ The possible need to for installation of additional monitoring wells or surface water locations; ○ Consideration of fate and transport mechanisms for potential impacts at receptors and/or specific risk assessment for GDEs; • The consent holder is to notify DCCEE, DPH and NPWS within 7 days of receiving notification from the environmental consultant of the second or third consecutive exceedance and/or in the event two consecutive annual sample exceed the trigger value where the result is considered potentially related to site impacts.

It is noted that the laboratory results do not provide a direct indication of an exceedance, the determination of which requires data collation, quality control checking, data analyses and interpretation. The 7 day notification period is intended to apply once the site operator became aware of reportable exceedances.

2.7 Reporting

An annual report should be prepared which shall include the following:

- Time and date of sampling;
- Sampling methods, including field parameters records;
- Sample chain of custody documentation;
- Results of quality assurance / quality control (QA/QC) protocols;
- Laboratory test methods and laboratory limit of reporting (LOR);
- Tabulated results of field testing (Category 1 parameters);
- Tabulated results of laboratory testing (Category 2 parameters and any other testing);
- Plot of laboratory testing results over time for key parameters to allow assessment of trends;
- Comparison with previous surface water monitoring data and assessment of trends in surface water quality noting any exceedances of criteria and actions taken.

2.8 Review and continuous improvement of the monitoring program and effectiveness

Potential improvements to the monitoring program or site practices should be included in the annual reports.

A revision of the monitoring program is an important aspect of continuous improvement. Review should be undertaken by a suitably qualified groundwater / surface water consultant:

- Following significant environmental incidents;
- When material improvements to performance have been recommended by the consultant in annual reports or as directed by the environmental authority;
- When new stages of construction are proposed (e.g. Stage 2 development);
- Otherwise, every five years to:
 - o Review changes in land uses within the site and for adjacent sites which may increase potential contamination sources and/or potential contaminants of concern;
 - o Analyse trends in surface water flows/volumes and quality for comparison against the long term data set;
 - o Review trigger levels and update, if warranted;
 - o Assess the effectiveness of existing monitoring program and whether the objectives/intention of the monitoring program are being met; and
 - o Recommend any changes to provide an efficient and effective monitoring programme, such as changes to the network of monitoring locations, frequency of testing and nominated test parameters.

Parameters which have been established to be of minimal concern from the results of monitoring may be dropped from the program and others may be added, if warranted.

2.9 Summary of improvements and modification to surface water monitoring

Table 5 below provides a summary of the key improvements and modifications to the surface water monitoring procedure.

Table 5: Summary of key amendments

Attribute	Summary of improvements
Surface water monitoring locations	Formal inclusion of upgradient and cross gradient surface water monitoring locations which were included in the monitoring program from 2013.
Monitoring parameters and analytes	The results of site monitoring and site usage indicates that monitoring for OCP/OPP is no longer warranted. Phenols have been formally added to monitoring parameters and have been routinely tested. Monitoring for PFAS compounds has been added.
Monitoring frequency	The monitoring frequency for the long term site conditions has been standardised to annually. Quarterly monitoring is still recommended for any construction periods.
Actions prompted by monitoring results	The actions have been updated to represent contemporary practices and allow for considered investigation of potential exceedances. Additional clarity has been provided with regards to timing of notifications.
Review of monitoring effectiveness and continuous improvement	Additional guidance has been provided on applying the principal of continuous improvement for the monitoring methodology. This includes review of the relevant site assessment criteria for water quality and update if required (Section 2.8).

3. References

ADWJ. (January 2010). *Soil and Water Management Report including Stormwater Management Scheme, Site Water Balance and Erosion and Sediment Control for WesTrac Facility at Tomago Road, Tomago*. Document 11886_Soil and Water Version C: ADW Johnson Pty Ltd.

ANZECC. (2000). *Australian and New Zealand Guidelines for Fresh and Marine Water Quality*. Australia and New Zealand Environment and Conservation Council.

ANZG. (2018). *Australian and New Zealand Guidelines for Fresh and Marine Water Quality*. Canberra, ACT: Australian and New Zealand Governments and Australian state and territory governments.

ANZG. (2023). *Using monitoring data to derive and assess against guideline values*. Retrieved from Australian and New Zealand Guidelines for Fresh & Marine Water Quality:

<https://www.waterquality.gov.au/anz-guidelines/monitoring/data-analysis/derivation-assessment>

Douglas. (2010a). *Groundwater Monitoring Plan, Proposed Industrial Subdivision, Tomago Road, Tomago*. Document No. 39920.02-GMP Rev1: Douglas Partners Pty Ltd.

Douglas. (2024c). *Report on Summary of Groundwater and Surface Water Monitoring - 2010 to 2024, Stages 1-3 Northbank Enterprise Hub, WesTrac Drive, Tomago NSW*. Ref 39920.09.R.013.Rev1: Douglas Partners Pty Ltd.

Douglas. (2025). *Revised Groundwater Monitoring Plan, Stage 1 Northbank Enterprise Hub (EPBC Approval 2007/3343), Lot 212 and Part Lot 211 DP 1174939, Westrac Drive, Tomago, NSW*. Document 39920.09.R.016.Rev0: Douglas Partners Pty Ltd.

HEPA. (2020). *PFAS National Environmental Management Plan (NEMP)*. Version 2.0: Heads of EPAs Australia and New Zealand and Australian Government Department of the Environment.

NHMRC, NRMCC. (2021). *Australian Drinking Water Guidelines 6 2011, Version 3.6*. Canberra: National Health and Medical Research Council, National Resource Management Ministerial Council.

NSW EPA. (2020). *Guidelines for Consultants Reporting on Contaminated Land*. Contaminated Land Guidelines: NSW Environment Protection Authority.

4. Limitations

Douglas Partners (Douglas) has prepared this report for this project at Lot 211-Lot 212 D.P.1174939, WesTrac Drive, Tomago with reference to Douglas' proposal 39920.09.P.011.Rev1 dated 7 November 2024 and acceptance received from Northbank Enterprise Hub Pty Ltd. The work was carried out under agreed terms between Douglas Partners Pty Ltd and Northbank Enterprise Hub Pty Ltd (Contract 20230206 ACE-LEG-005A executed 23 February 2023). This report is provided for the exclusive use of Northbank Enterprise Hub Pty Ltd for this project only and for the purposes as described in the report. It should not be used by or relied upon for other projects or purposes on the same or other site or by a third party. Any party so relying upon this report beyond its exclusive use and purpose as stated above, and without the express written consent of Douglas, does so entirely at its own risk and without recourse to Douglas for any loss or damage. In preparing this report Douglas has necessarily relied upon information provided by the client and/or their agents.

The results provided in the report are indicative of the sub-surface conditions at the specific sampling and/or testing locations, and then only to the depths investigated and at the time the work was carried out, as reported by Douglas and others. Sub-surface and groundwater conditions can change abruptly due to variable geological processes and also as a result of human influences.

Douglas' advice is based upon the conditions encountered during previous investigations as reported by others. The accuracy of the advice provided by Douglas in this report may be affected by undetected variations in ground conditions across the site between and beyond the sampling and/or testing locations. The advice may also be limited by budget constraints imposed by others or by site accessibility.

The assessment of atypical safety hazards arising from this advice is restricted to the environmental / groundwater components set out in this report and based on known project conditions and stated design advice and assumptions. While some recommendations for safe controls may be provided, detailed 'safety in design' assessment is outside the current scope of this report and requires additional project data and assessment.

This report must be read in conjunction with all of the attached and should be kept in its entirety without separation of individual pages or sections. Douglas cannot be held responsible for interpretations or conclusions made by others unless they are supported by an expressed statement, interpretation, outcome or conclusion stated in this report.

This report, or sections from this report, should not be used as part of a specification for a project, without review and agreement by Douglas. This is because this report has been written as advice and opinion rather than instructions for construction.

Appendix 1

Drawing 5 – Groundwater and Surface Water
Monitoring Locations

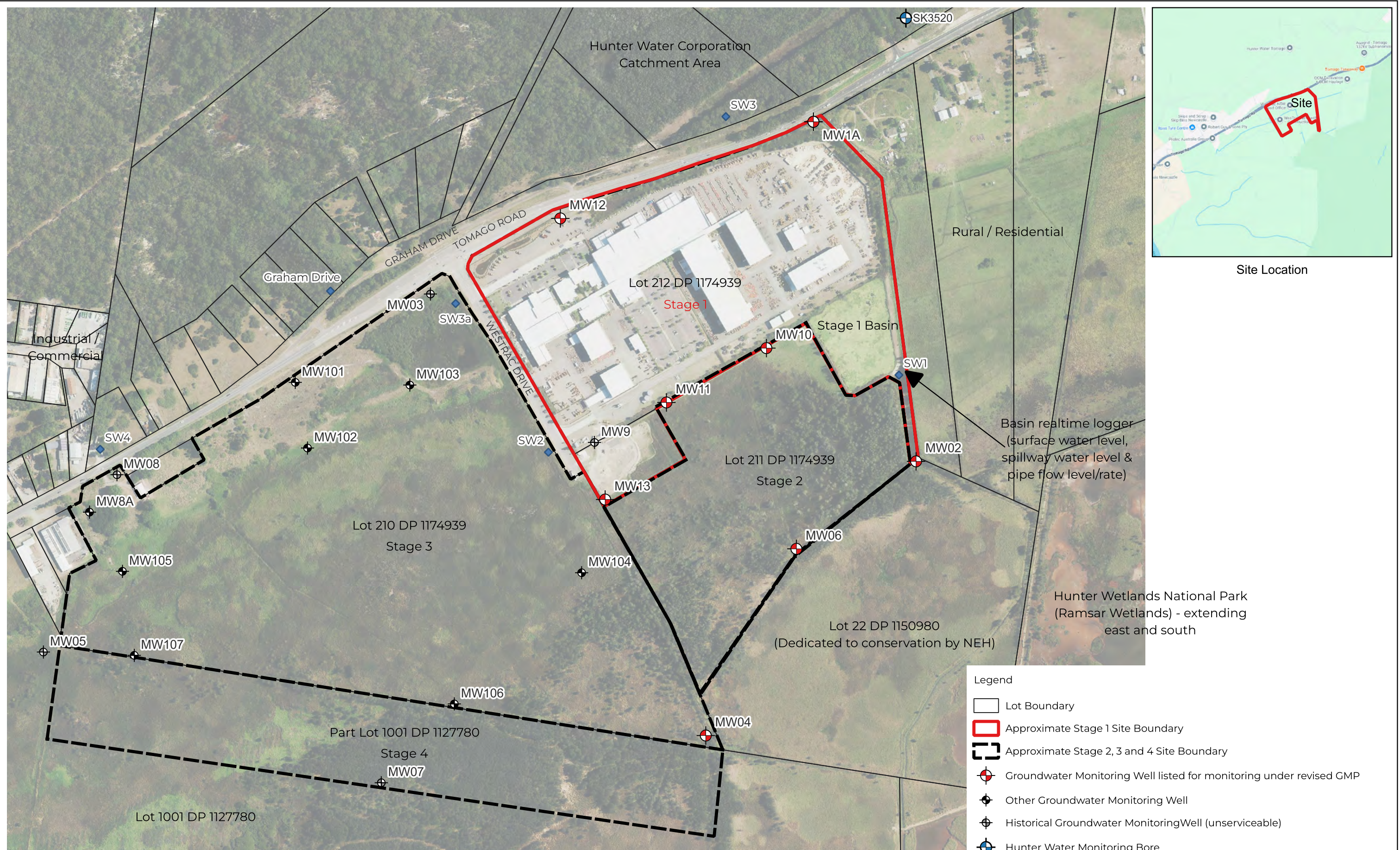

Site Location

- Legend
- Lot Boundary
 - Approximate Stage 1 Site Boundary
 - Approximate Stage 2, 3 and 4 Site Boundary
 - Groundwater Monitoring Well listed for monitoring under revised GMP
 - Other Groundwater Monitoring Well
 - Historical Groundwater Monitoring Well (unserviceable)
 - Hunter Water Monitoring Bore
 - Surface Water Monitoring Location

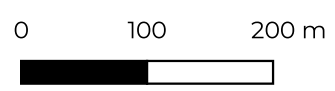

Drawing adapted from Metromap Image dated 12.02.2023.
 Test locations are approximate only. MW8A and MW100 series wells located using differential GPS.
 MW1A & MW12 - Groundwater monitoring well (installed August 2024).



CLIENT: Northbank Enterprise Hub Pty Ltd	
OFFICE: Newcastle	DRAWN BY: CET
SCALE: 1:6000 @ A3	DATE: 03.03.2025

TITLE: Groundwater and Surface Water Monitoring Monitoring Locations
 Stage 1, Northbank Enterprise Hub
 Westrac Drive, Tomago

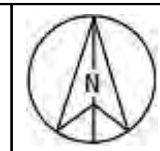

PROJECT No:39920.09
DRAWING No: 5
REVISION: 1

Appendix 2

About this Report

Introduction

These notes have been provided to amplify Douglas' report in regard to classification methods, field procedures and the comments section. Not all are necessarily relevant to all reports.

Douglas' reports are based on information gained from limited subsurface excavations and sampling, supplemented by knowledge of local geology and experience. For this reason, they must be regarded as interpretive rather than factual documents, limited to some extent by the scope of information on which they rely.

Copyright

This report is the property of Douglas Partners Pty Ltd. The report may only be used for the purpose for which it was commissioned and in accordance with the Engagement Terms for the commission supplied at the time of proposal. Unauthorised use of this report in any form whatsoever is prohibited.

Borehole and Test Pit Logs

The borehole and test pit logs presented in this report are an engineering and/or geological interpretation of the subsurface conditions, and their reliability will depend to some extent on frequency of sampling and the method of drilling or excavation. Ideally, continuous undisturbed sampling or core drilling will provide the most reliable assessment, but this is not always practicable or possible to justify on economic grounds. In any case the boreholes and test pits represent only a very small sample of the total subsurface profile.

Interpretation of the information and its application to design and construction should therefore take into account the spacing of boreholes or pits, the frequency of sampling, and the possibility of other than 'straight line' variations between the test locations.

Groundwater

Where groundwater levels are measured in boreholes there are several potential problems, namely:

- In low permeability soils groundwater may enter the hole very slowly or perhaps not at all during the time the hole is left open;
- A localised, perched water table may lead to an erroneous indication of the true water table;
- Water table levels will vary from time to time with seasons or recent weather

changes. They may not be the same at the time of construction as are indicated in the report; and

- The use of water or mud as a drilling fluid will mask any groundwater inflow. Water has to be blown out of the hole and drilling mud must first be washed out of the hole if water measurements are to be made.

More reliable measurements can be made by installing standpipes which are read at intervals over several days, or perhaps weeks for low permeability soils. Piezometers, sealed in a particular stratum, may be advisable in low permeability soils or where there may be interference from a perched water table.

Reports

The report has been prepared by qualified personnel, is based on the information obtained from field and laboratory testing, and has been undertaken to current engineering standards of interpretation and analysis. Where the report has been prepared for a specific design proposal, the information and interpretation may not be relevant if the design proposal is changed. If this happens, Douglas will be pleased to review the report and the sufficiency of the investigation work.

Every care is taken with the report as it relates to interpretation of subsurface conditions, discussion of geotechnical and environmental aspects, and recommendations or suggestions for design and construction. However, Douglas cannot always anticipate or assume responsibility for:

- Unexpected variations in ground conditions. The potential for this will depend partly on borehole or pit spacing and sampling frequency;
- Changes in policy or interpretations of policy by statutory authorities; or
- The actions of contractors responding to commercial pressures.

If these occur, Douglas will be pleased to assist with investigations or advice to resolve the matter.

About this Report

Site Anomalies

In the event that conditions encountered on site during construction appear to vary from those which were expected from the information contained in the report, Douglas requests that it be immediately notified. Most problems are much more readily resolved when conditions are exposed rather than at some later stage, well after the event.

Information for Contractual Purposes

Where information obtained from this report is provided for tendering purposes, it is recommended that all information, including the written report and discussion, be made available. In circumstances where the discussion or comments section is not relevant to the contractual situation, it may be appropriate to prepare a specially edited document. Douglas would be pleased to assist in this regard and/or to make additional report copies available for contract purposes at a nominal charge.

Site Inspection

The company will always be pleased to provide engineering inspection services for geotechnical and environmental aspects of work to which this report is related. This could range from a site visit to confirm that conditions exposed are as expected, to full time engineering presence on site.

intentionally blank

Appendix 3

Table E3: Surface Water Quality Assessment Criteria

Table E3: Surface Water Quality Assessment Criteria

	Unit	LOR	Monitoring data 2010-2025			ANZG Marine Water Toxicant DGVs 95% LOSP	Notes to ANZG	HEPA (2020) NEMP 2020 Interim Marine 95% LOSP for protection of aquatic ecosystems	Comments
			No of readings	Minimum	Maximum				
Physio chemical parameters (field)									
pH (Field)	pH	0.1	47	4.67	9.34	7.0-8.0	#14		
Electrical Conductivity (field)	µS/cm	1	44	56	833	125-2200	#15		General indicator water quality value rather than contaminants of concern
DO (Field)	mg/L	0.1	37	0.17	96.2				
DO (Field)	%	1	-	-	-	80-110%	#14		
Turbidity (Field)	NTU	1	-	-	-	0.5-10	#14		
Temperature (Field)	°C	-	-	-	-				
Physio chemical parameters									
Total Suspended Solids	mg/L	5	17	2.5	1720				TSS in surface water can vary per monitoring event. General indicator water quality value
Anions									
Chloride	mg/L	1	33	6	68				General indicator water quality value for surface water rather than contaminants of concern
Sulphate	mg/L	1	37	0.5	45				
Fluoride	mg/L	0.1	33	<0.1	0.3				
Alkalinity (Hydroxide) as CaCO3	mg/L	5	30	0.5	2.5				
Alkalinity (Carbonate as CaCO3)	mg/L	5	35	0.5	6				
Alkalinity (total) as CaCO3	mg/L	5	30	0.5	141				
Alkalinity (Bicarbonate as CaCO3)	mg/L	5	37	0.5	141				
Hardness (filtered)	mg/L	3	4	15	27				
Nutrients									
Ammonia as N (filtered)	mg/L	0.005	36	<0.005	1.6	0.91	#1		
Total Kjeldahl Nitrogen	mg/L	0.1	37	0.2	70.8				TKN, nitrate, nitrite etc are all measures of nitrogen species. The trigger level for ammonia is generally considered most applicable to assessing nitrogen concentrations in groundwater.
Nitrate (as N) (filtered)	mg/L	0.005	21	<0.005	0.38				
Nitrite (as N) (filtered)	mg/L	0.005	21	<0.005	0.11				
Nitrogen (Total Oxidised)	mg/L	0.005	34	<0.005	0.95	0.015	#15		
Nitrogen (Total)	mg/L	0.1	11	0.5	27.3	0.3	#15		
Total Phosphorus (Organic Phosphate)	mg/L	0.05	37	0.01	7.81	0.03	#15		
Reactive Phosphorus as P (Orthophosphate as P) (filtered)	mg/L	0.005	8	<0.005	0.02	0.005	#15		
Cations									
Calcium	mg/L	0.5	32	2	19.4				General indicator water quality value for rather than contaminants of concern
Magnesium	mg/L	0.5	32	0.8	6.9				
Potassium	mg/L	0.5	32	<0.5	15				
Sodium	mg/L	0.5	32	1	48				
Metals (filtered or dissolved)									
Aluminium	mg/L	0.01	-	-	-	0.0005	#4		
Arsenic	mg/L	0.001	38	<0.001	0.075	0.0023 (As V)	#16		
Cadmium	mg/L	0.0001	38	<0.0001	0.0004	0.0055	#2		
Chromium (III+VI)	mg/L	0.001	38	<0.001	0.035	0.0044 (Cr VI)	#17		
Copper	mg/L	0.001	38	<0.001	0.032	0.0013	#3		
Iron	mg/L	0.01	31	0.658	510				
Lead	mg/L	0.001	38	0.0001	0.027	0.0044	#4		
Manganese	mg/L	0.005	32	0.013	4.0				
Mercury	mg/L	0.00005	38	<0.00005	<0.00005	0.0004	#3		
Molybdenum	mg/L	0.001	36	<0.001	0.003	0.023	#18		
Nickel	mg/L	0.001	38	<0.001	0.011	0.07	#3		
Zinc	mg/L	0.001	38	0.0025	0.54	0.008	#6		
TRH									
C6-C10 Fraction (F1)	mg/L	0.01	29	<0.01	0.01	LOR			
C6-C10 (F1 minus BTEX)	mg/L	0.01	29	<0.01	0.01	LOR			
>C10-C16 Fraction (F2)	mg/L	0.05	29	<0.05	0.15	LOR			
>C10-C16 Fraction (F2 minus Naphthalene)	mg/L	0.05	10	<0.05	0.05	LOR			
>C16-C34 Fraction (F3)	mg/L	0.1	29	<0.1	4.1	LOR			
>C34-C40 Fraction (F4)	mg/L	0.1	29	<0.1	0.47	LOR			
>C10-C40 Fraction (Sum)	mg/L	0.05	29	<0.05	4.72	LOR			
C6-C9 Fraction	mg/L	0.01	31	<0.01	0.025	LOR			
C10-C14 Fraction	mg/L	0.05	27	<0.05	0.19	LOR			
C15-C28 Fraction	mg/L	0.1	27	<0.1	2.64	LOR			
C29-C36 Fraction	mg/L	0.1	27	<0.1	1.73	LOR			
C10-C36 Fraction (Sum)	mg/L	0.05	24	<0.05	4.56	LOR			
TPH (Silica-Gel Cleanup)									
C10-C14 Fraction (SG)	mg/L	0.05	-	-	-	LOR			
C15-C28 Fraction (SG)	mg/L	0.1	-	-	-	LOR			
C29-C36 Fraction (SG)	mg/L	0.1	-	-	-	LOR			
>C10-C16 Fraction (SG)	mg/L	0.05	-	-	-	LOR			
>C16-C34 Fraction (SG)	mg/L	0.1	-	-	-	LOR			
>C34-C40 Fraction (SG)	mg/L	0.1	-	-	-	LOR			
BTEX									
Benzene	mg/L	0.001	35	<0.001	<0.001	0.7	#7		
Toluene	mg/L	0.001	35	<0.001	<0.001	0.18	#8		
Ethylbenzene	mg/L	0.001	35	<0.001	<0.001	0.08	#8		
Xylene (m & p)	mg/L	0.001	35	<0.002	<0.002				
Xylene (m)	mg/L	0.001	35	<0.002	<0.002	0.075	#7		
Xylene (o)	mg/L	0.001	35	<0.002	<0.002	0.35	#8		
Xylene (p)	mg/L	0.001	35	<0.002	<0.002	0.2	#8		
PAH									
Acenaphthene	mg/L	0.0001	39	<0.0001	<0.0001				
Acenaphthylene	mg/L	0.0001	39	<0.0001	<0.0001				
Anthracene	mg/L	0.0001	37	<0.0001	<0.0001	0.0004	#9		
Benzo(a)anthracene	mg/L	0.0001	39	<0.0001	<0.0001				
Benzo(b+j+k)fluoranthene	mg/L	0.0002	39	<0.0002	<0.0002				
Benzo(a) pyrene	mg/L	0.0001	39	<0.0005	<0.005	0.0002	#9		
Benzo(g,h,i)perylene	mg/L	0.0001	35	<0.0001	<0.001				
Chrysene	mg/L	0.0001	39	<0.0001	<0.0001				
Dibenz(a,h)anthracene	mg/L	0.0001	37	<0.0001	<0.0001				
Fluoranthene	mg/L	0.0001	37	<0.0001	<0.0001	0.0014	#9		
Fluorene	mg/L	0.0001	35	<0.0001	<0.0001				
Indeno(1,2,3-c,d)pyrene	mg/L	0.0001	39	<0.0001	<0.0001				
Naphthalene	mg/L	0.0001	35	<0.0001	<0.005	0.07	#7		
Phenanthrene	mg/L	0.0001	39	<0.0001	<0.005	0.002	#9		
Pyrene	mg/L	0.0001	37	<0.0001	<0.005				
PAHs (Sum of positives)	mg/L	0.0001	39	<0.0001	<0.005				
PCBs									
Aroclor 1016	mg/L	0.00001	-	-	-				
Aroclor 1221	mg/L	0.00001	-	-	-				
Aroclor 1232	mg/L	0.00001	-	-	-				
Aroclor 1242	mg/L	0.00001	26	<0.0001	<0.0001	0.0003	#9		
Aroclor 1248	mg/L	0.00001	-	-	-				
Aroclor 1254	mg/L	0.00001	22	<0.0001	<0.0001	0.00001	#9		
Sum PCBs	mg/L	0.00001	33	<0.0001	<0.0001				
PFAS									
Sum of PFHxS and PFOS	µg/L	0.0002	3	<0.0002	0.0051				
Perfluorooctane sulfonic acid (PFOS)	µg/L	0.0002	3	<0.0002	0.0028			0.00013	
Perfluorooctanoic acid (PFOA)	µg/L	0.0002	3	<0.0002	0.002			0.22	
Sum of positive PFAS	µg/L	0.0001	3	<0.0001	0.0094				

Comments

- LOSP - level of species protection
- UCL - upper confidence limit
- DGV - default guideline value
- #1 Moderate reliability. Ammonia as total ammonia, measured as [NH3-N] at pH 8.
- #2 High reliability. DGV may not protect key test species from chronic toxicity (this refers to experimental chronic values or geometric mean for species). Check toxicant DGV technical brief for spread of data and its significance.
- #3 Very high reliability
- #4 Low reliability guideline value
- #4 Low reliability guideline value - "indicative interim working level". Criteria not pH dependent and may be based on waters > pH 6.5
- #5 High reliability
- #6 Very high reliability. Recommended for application for slightly to moderately disturbed ecosystems. However, this DGV may be under-protective for key sensitive species (e.g. bivalve molluscs, cnidarians)
- #7 Moderate reliability. DGV may not protect key test species from chronic toxicity (this refers to experimental chronic values or geometric mean for species). Check toxicant DGV technical brief for spread of data and its significance.
- #8 Unknown reliability. Recommended for application for slightly to moderately disturbed ecosystems.
- #9 Low reliability freshwater criteria for OCP
- #10 Moderate reliability
- #11 Unknown reliability. To account for the bioaccumulating nature of this toxicant, it is recommended that the 99% species protection level DGV is used for slightly to moderately disturbed systems. Also see General comments.
- #12 To account for the bioaccumulating nature of this toxicant, it is recommended that the 99% species protection level DGV is used for slightly to moderately disturbed systems. Refer to Warne et al. (2017) for details.
- #14 ANZECC 2000 DTVs for physical and chemical stressors for SE Aust for slightly disturbed ecosystems - Low land rivers (Table 3.3.3)
- #15 ANZECC 2000 DTVs for physical and chemical stressors for SE Aust for slightly disturbed ecosystems - Estuaries (Table 3.3.2)
- #16 An Environmental Concern Level (ECL) of 2.3 µg/L was derived for As (III) in marine waters, using an assessment factor (AF) of 100. Refer Section 8.3.4.5 of the ANZECC & ARMCANZ (2000). This figure has been adopted as a marine low reliability trigger value, to be used
- #17 Chromium VI levels adopted as initial screen for total chromium. Very high reliability.
- #18 An environmental concern level (ECL) (refer to Section 8.3.4.5 of the ANZECC & ARMCANZ 2000 guidelines) of 23 µg/L is derived from an AF of 200 (as Mo is an essential element) and this was adopted as a low reliability trigger value. Both of these figures should only

Environmental Standards

ANZG, July 2023, ANZG Marine Water Toxicant DGVs LOSP 95% (July 2023)
 HEPA (2020) NEMP 2020 Interim Marine 95% LOSP for protection of aquatic ecosystems

Statistics

* A Non Detect Multiplier of 0.5 has been applied.

Appendix 4

Groundwater Quality Plots

Surface Water Quality Plots

GROUNDWATER QUALITY MONITORING
Tomago Northbank Enterprise Hub
Data Period: 2007 to January 2025

Data set: All data

Project: 39920.09

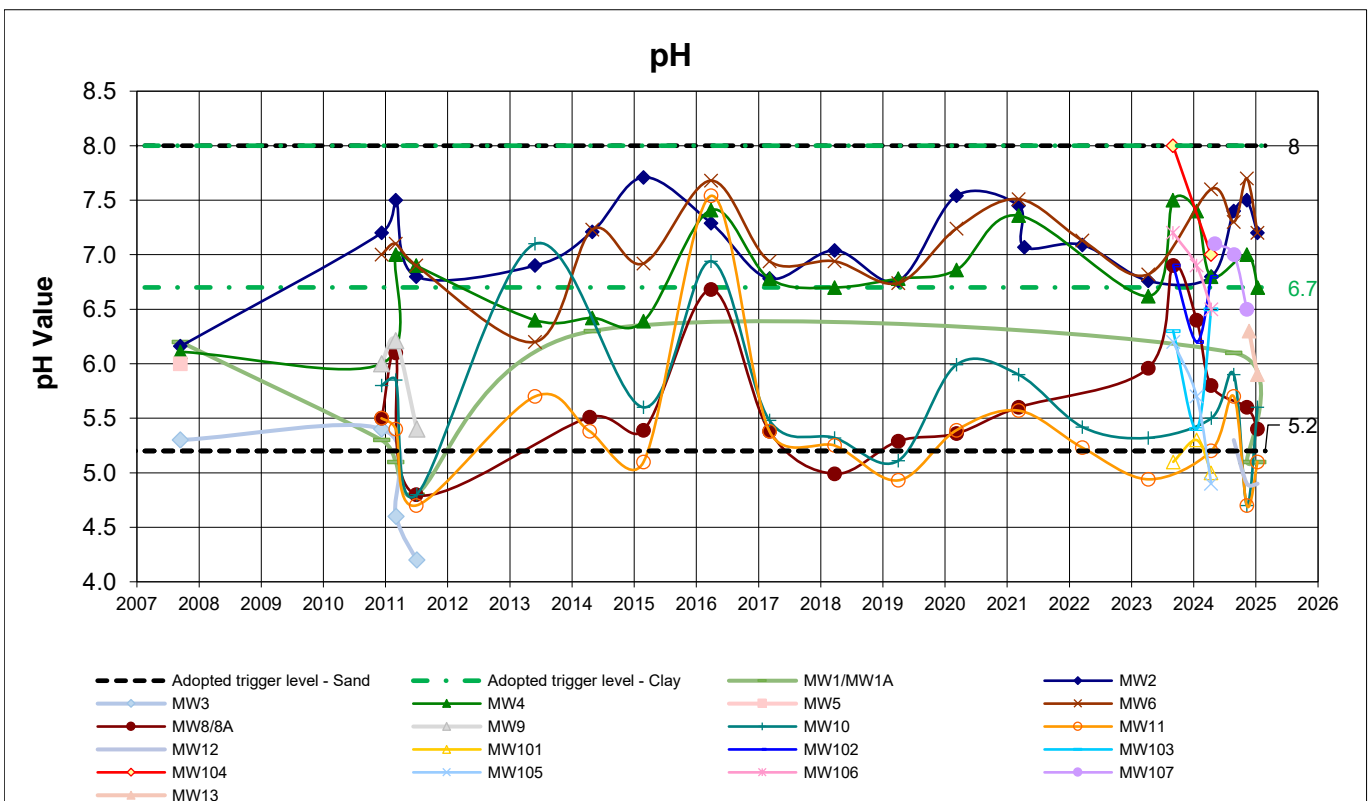
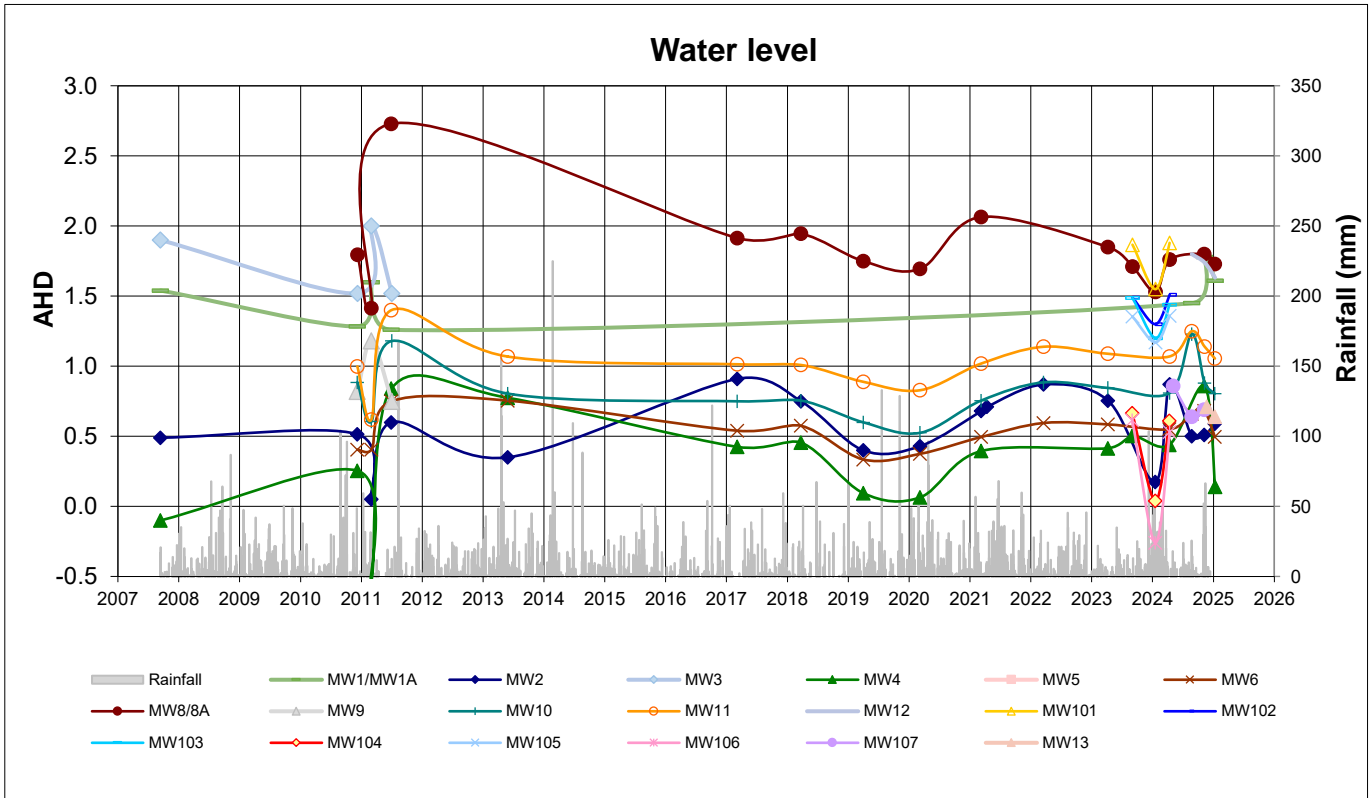

1. Values reported below PQL are plotted as half PQL
2. If a Criterion line is not plotted, there is no criteria

GROUNDWATER QUALITY MONITORING
Tomago Northbank Enterprise Hub
Data Period: 2007 to January 2025

Data set: All data

Project: 39920.09

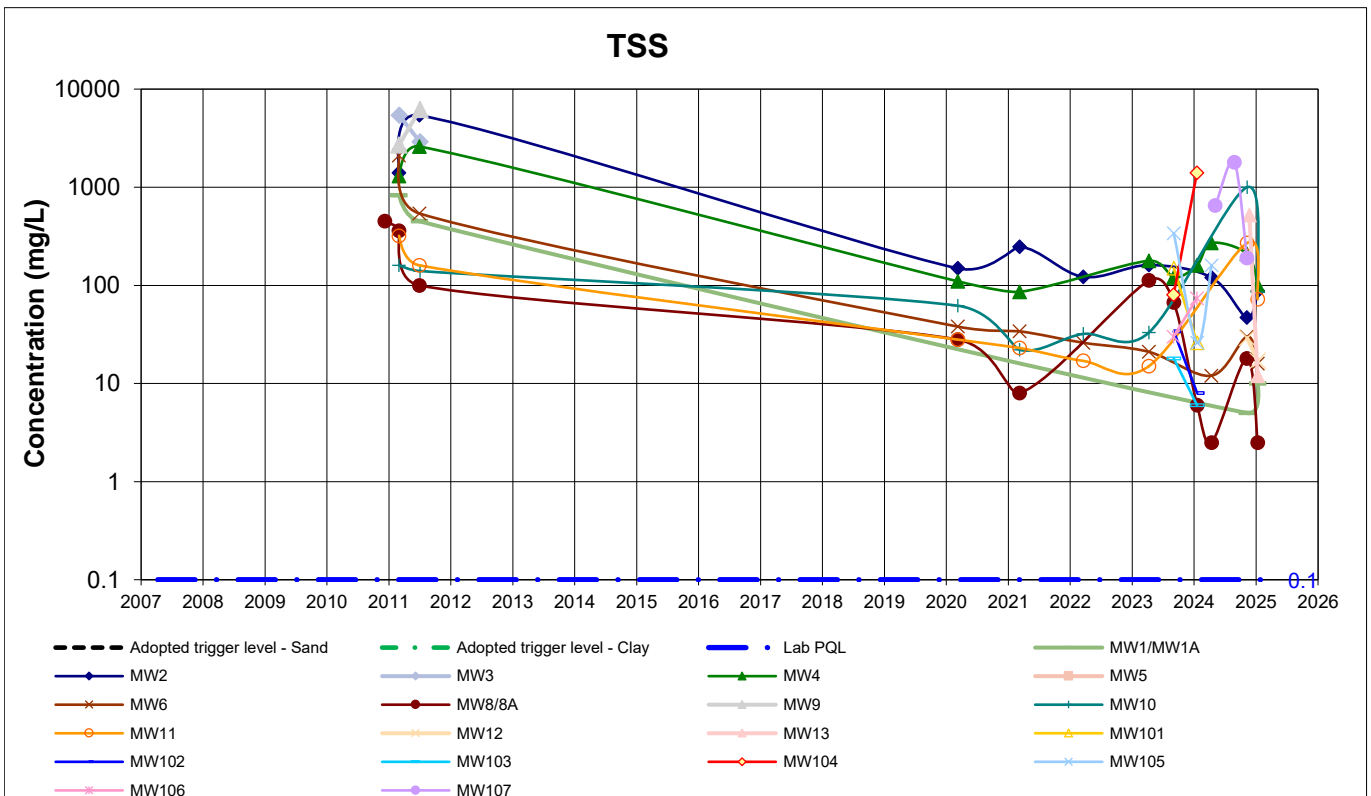
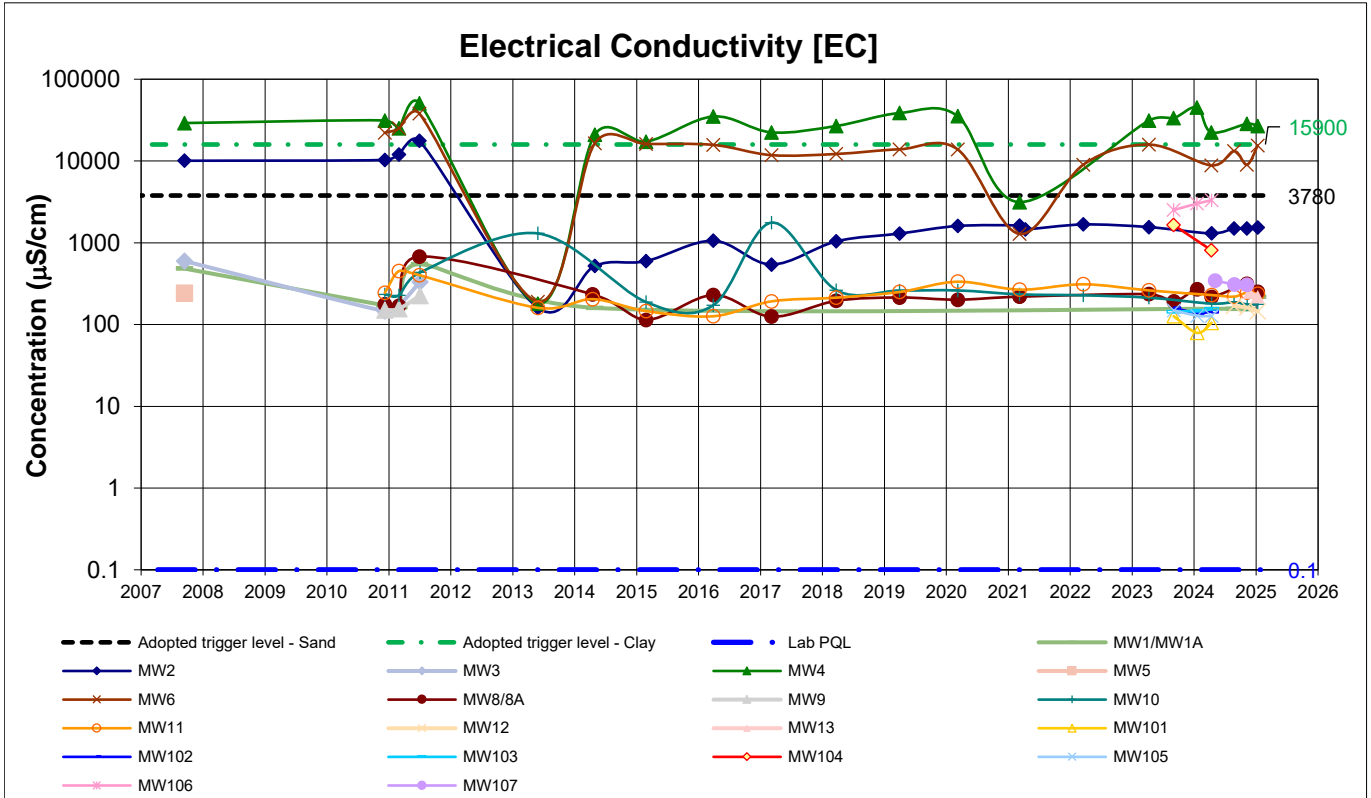

1. Values reported below PQL are plotted as half PQL
2. If a Criterion line is not plotted, there is no criteria

GROUNDWATER QUALITY MONITORING
Tomago Northbank Enterprise Hub
Data Period: 2007 to January 2025

Data set: All data

Project: 39920.09

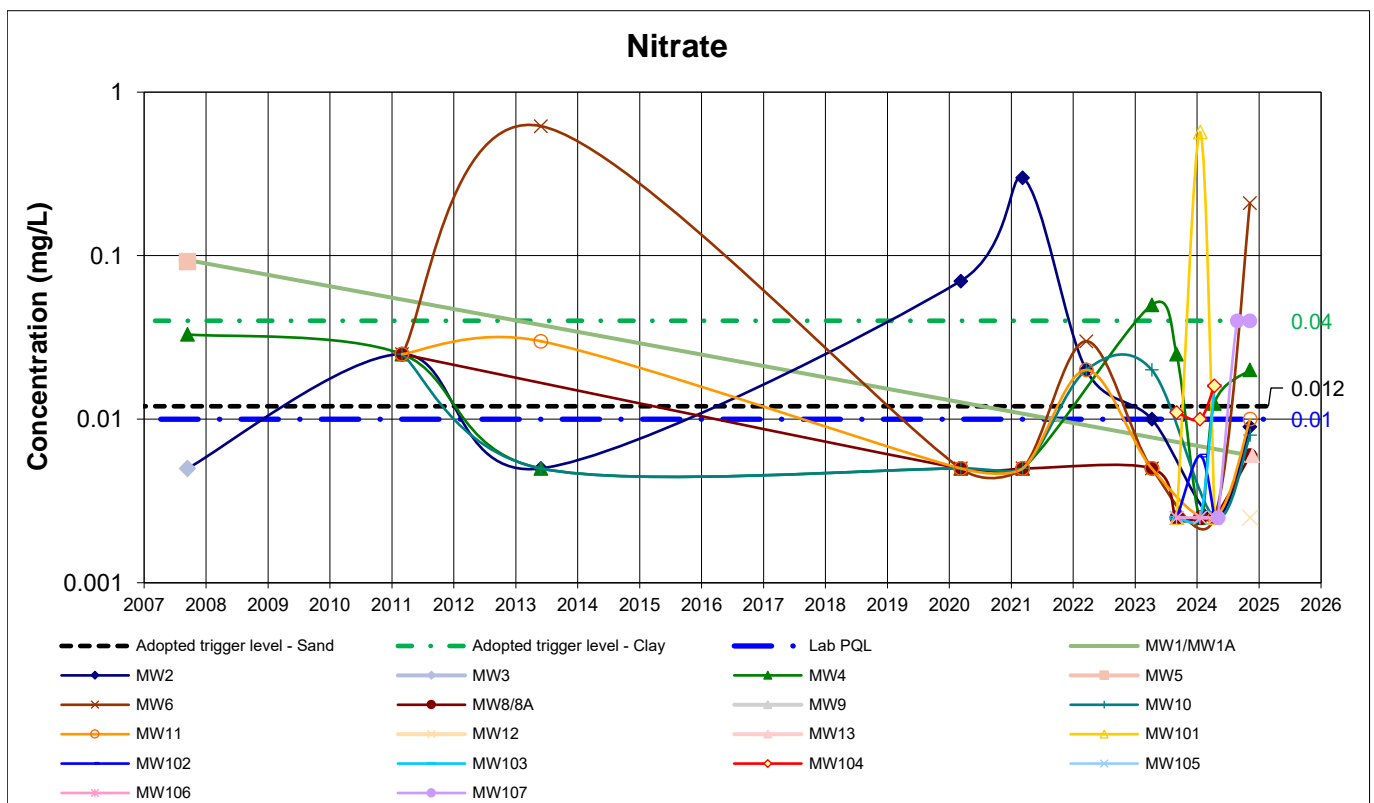
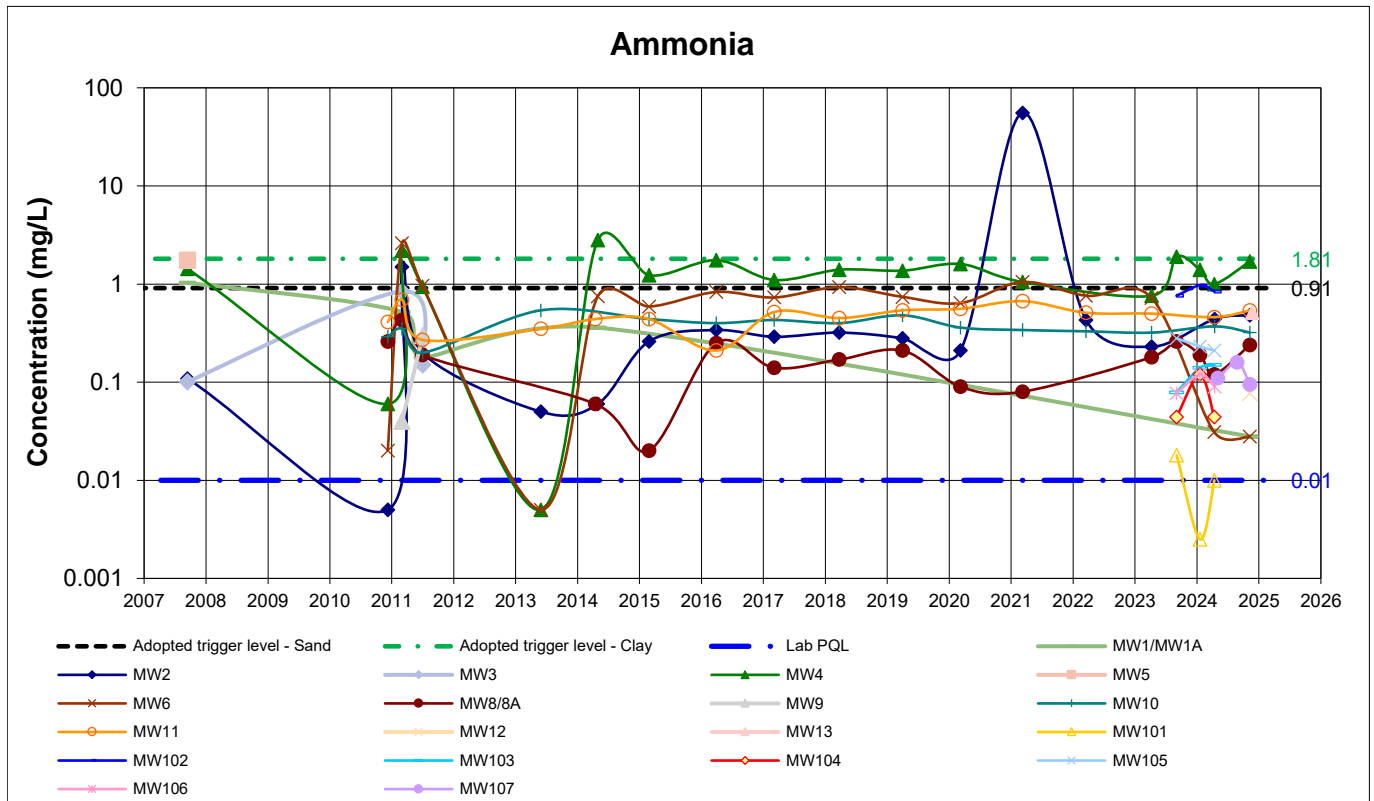

1. Values reported below PQL are plotted as half PQL
 2. If a Criterion line is not plotted, there is no criteria

GROUNDWATER QUALITY MONITORING
Tomago Northbank Enterprise Hub
Data Period: 2007 to January 2025

Data set: All data

Project: 39920.09

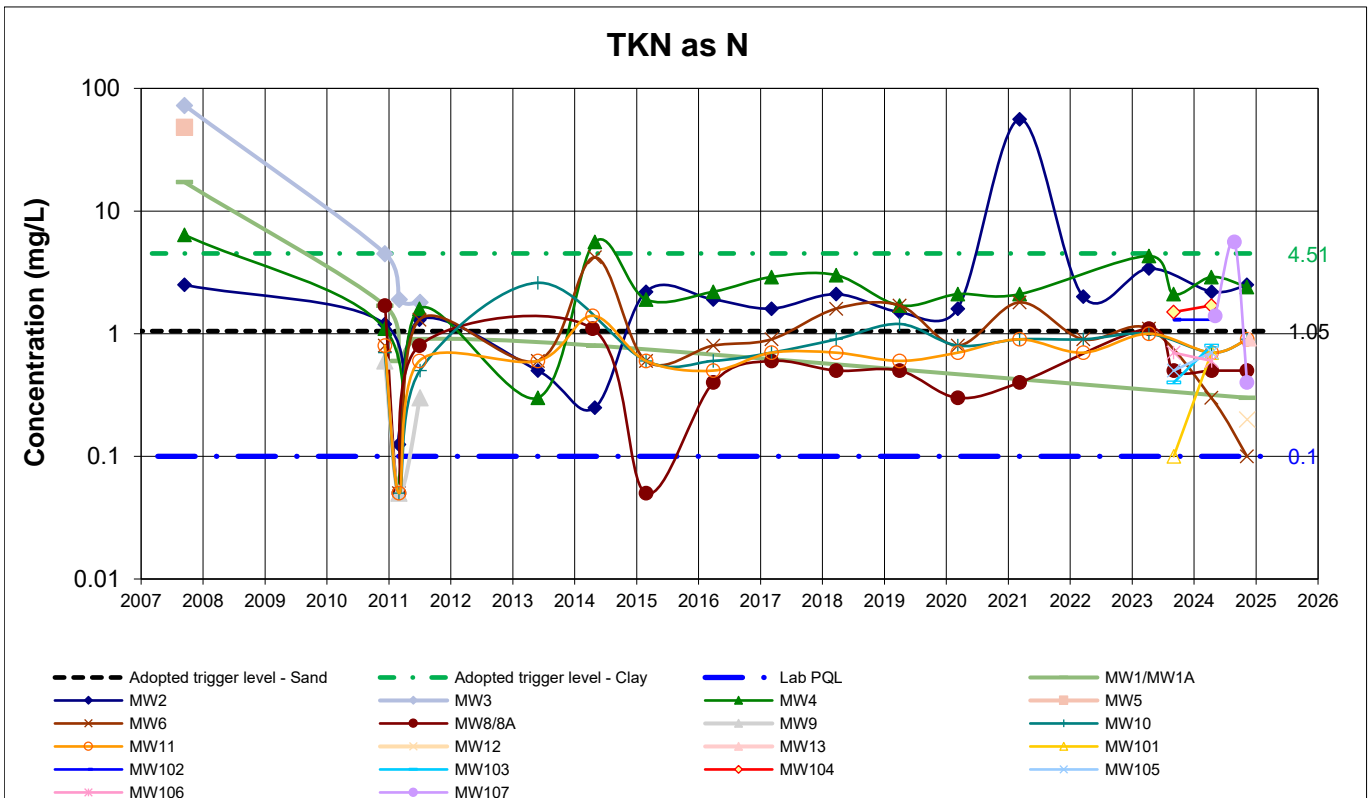
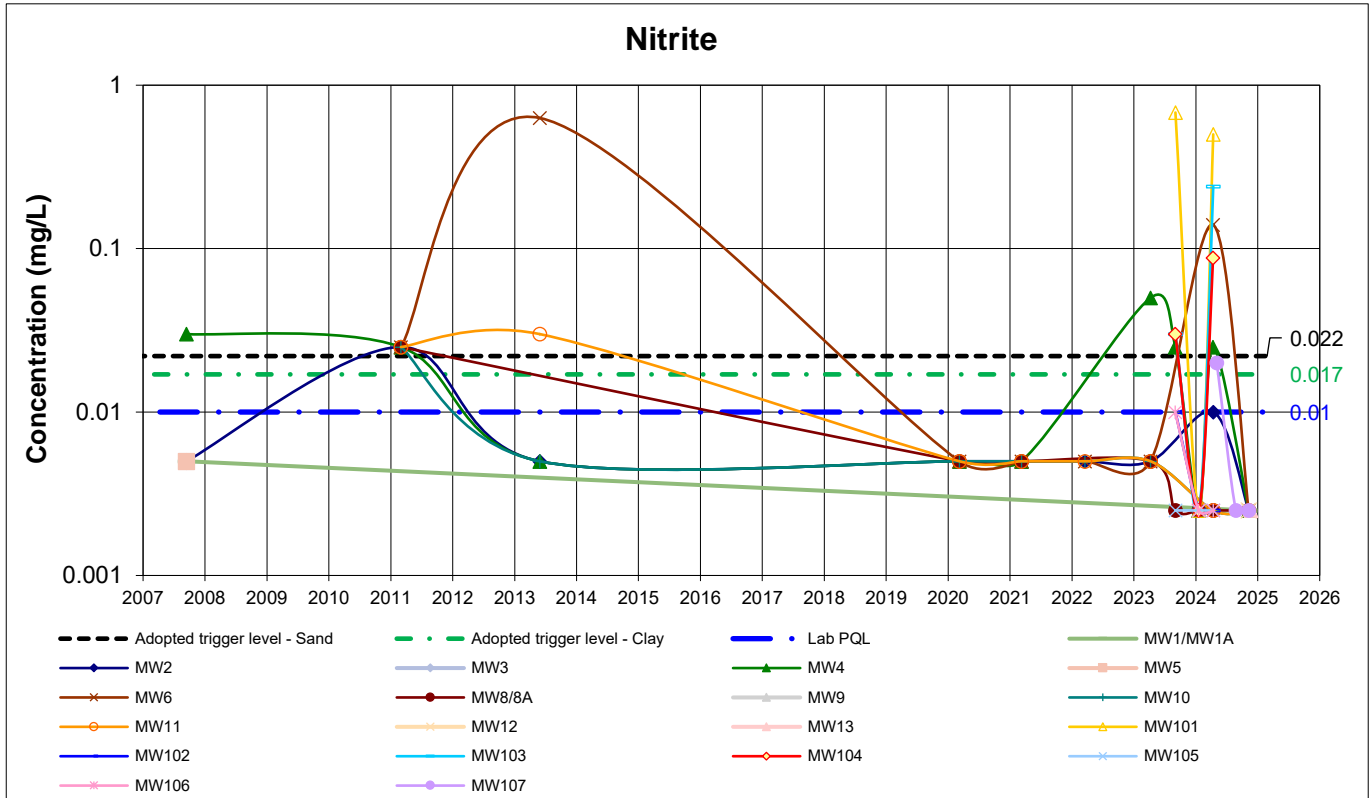

1. Values reported below PQL are plotted as half PQL
2. If a Criterion line is not plotted, there is no criteria

GROUNDWATER QUALITY MONITORING
Tomago Northbank Enterprise Hub
Data Period: 2007 to January 2025

Data set: All data

Project: 39920.09

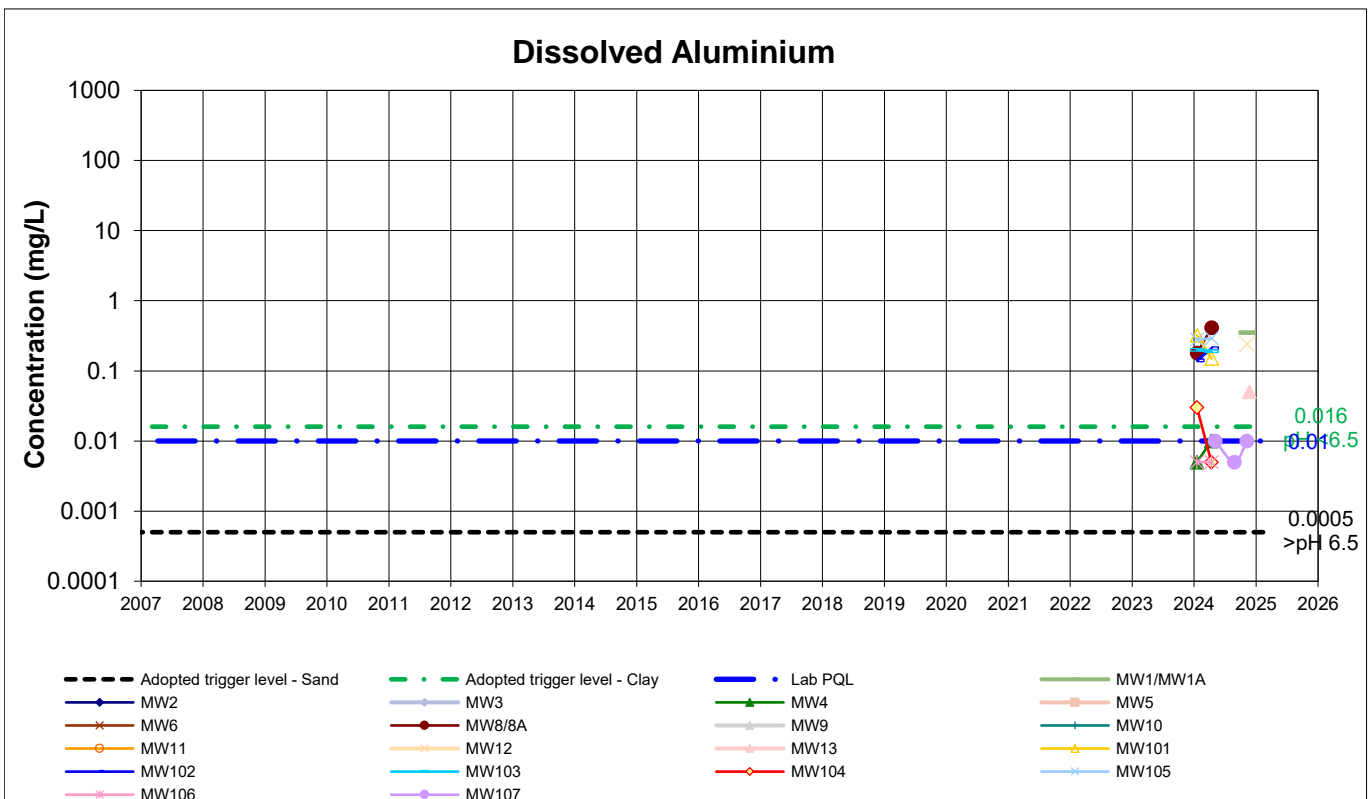
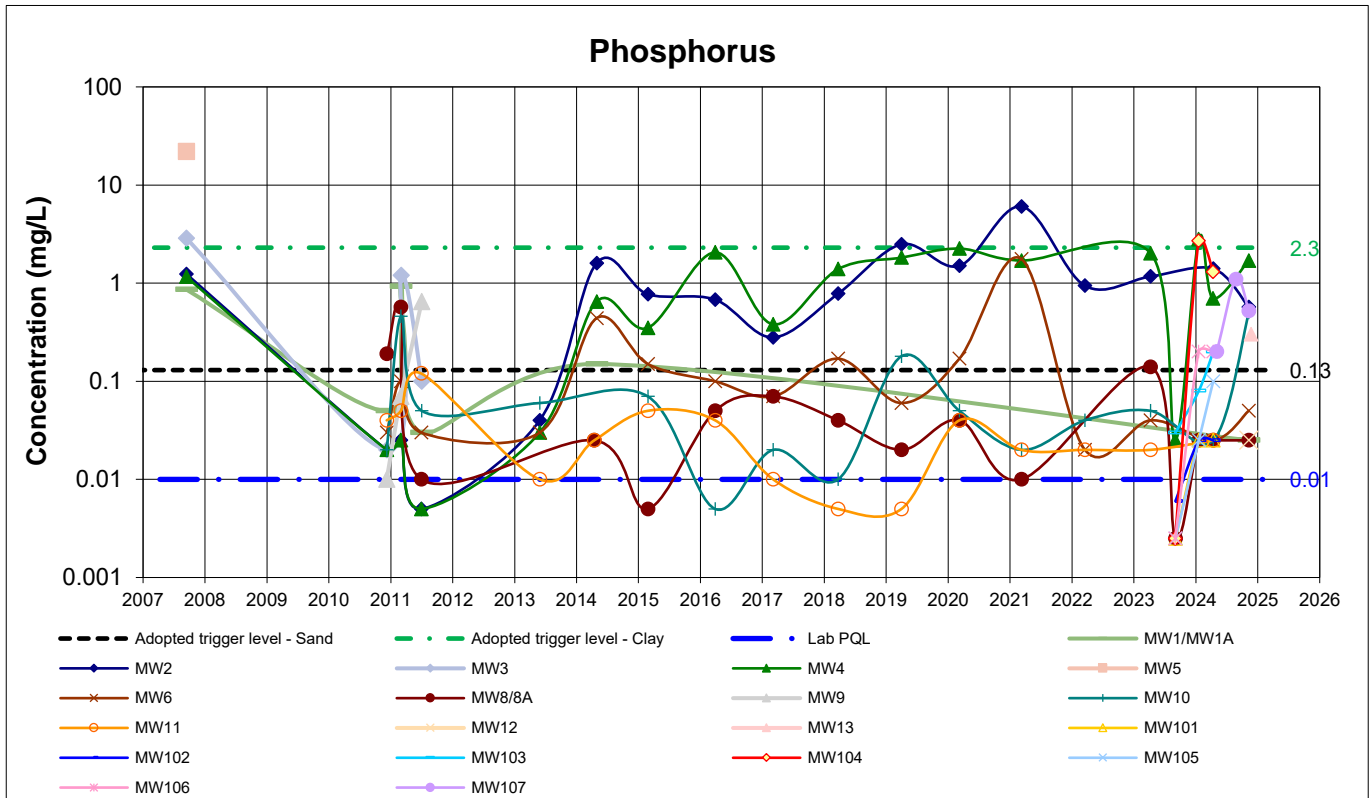

1. Values reported below PQL are plotted as half PQL
2. If a Criterion line is not plotted, there is no criteria

GROUNDWATER QUALITY MONITORING
Tomago Northbank Enterprise Hub
Data Period: 2007 to January 2025

Data set: All data

Project: 39920.09

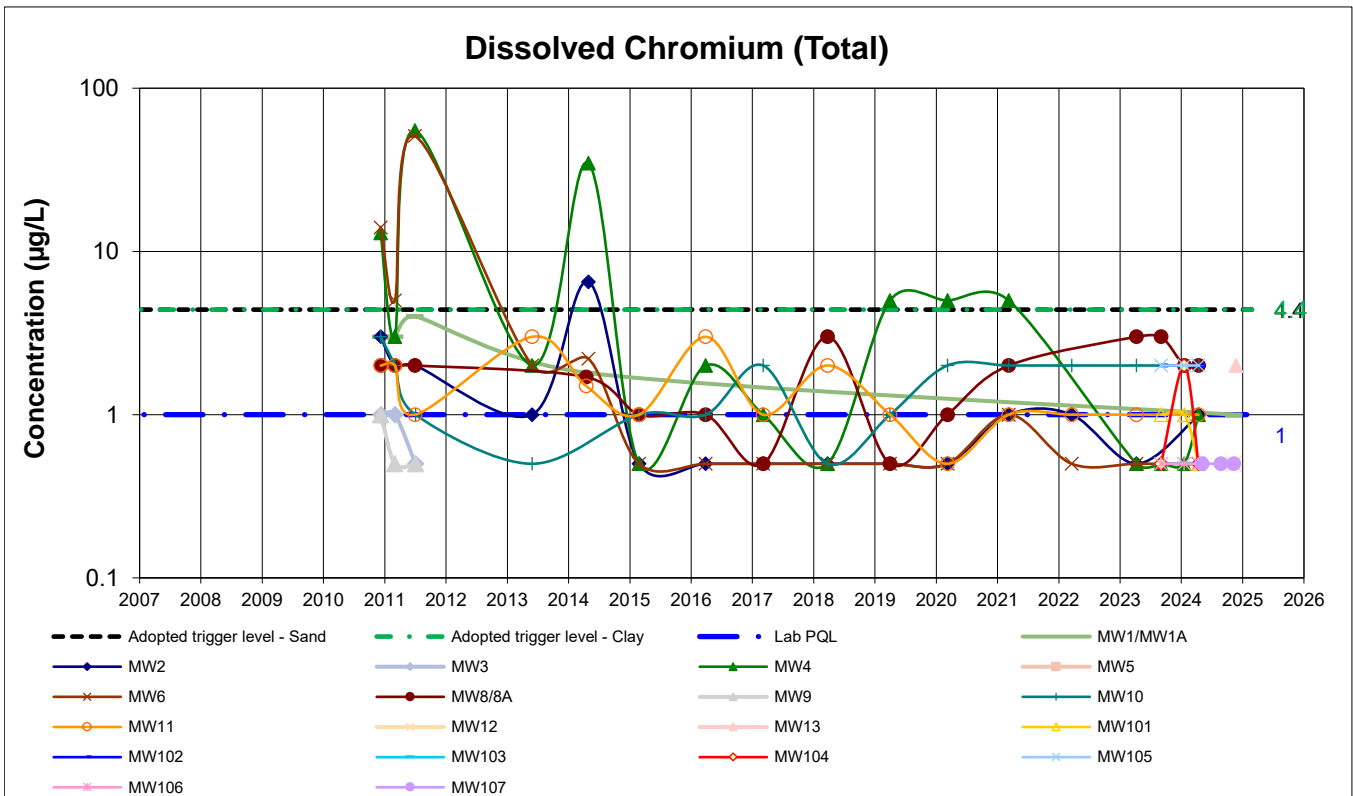
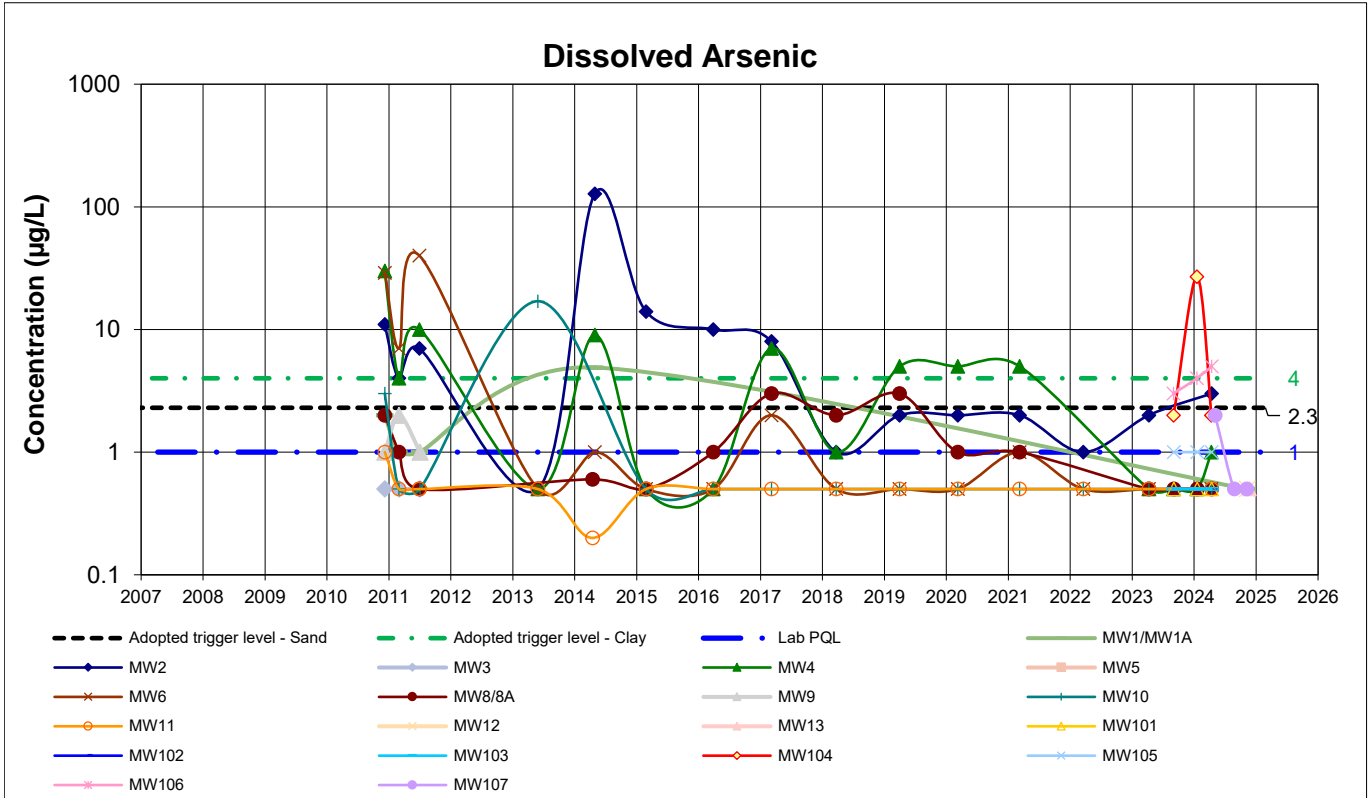

1. Values reported below PQL are plotted as half PQL
 2. If a Criterion line is not plotted, there is no criteria

GROUNDWATER QUALITY MONITORING
Tomago Northbank Enterprise Hub
Data Period: 2007 to January 2025

Data set: All data

Project: 39920.09

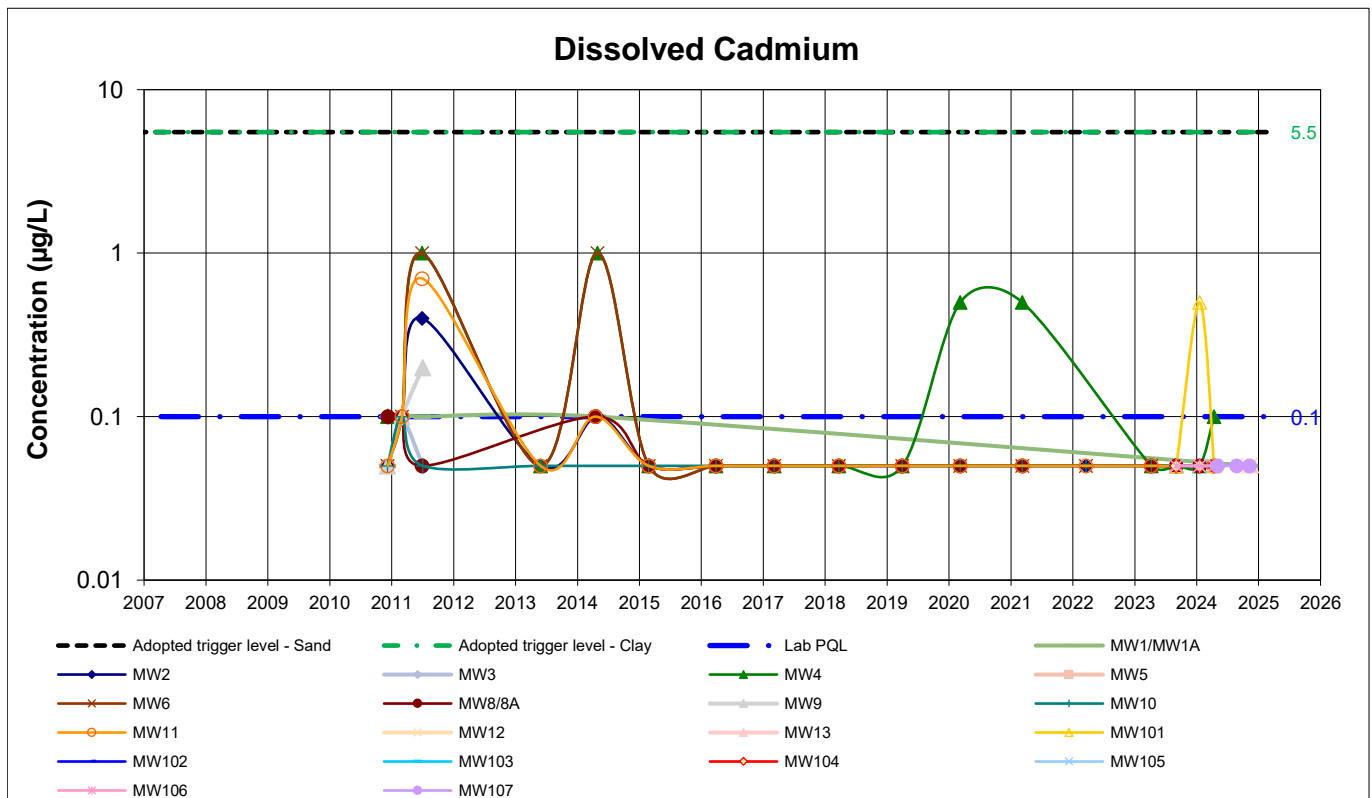
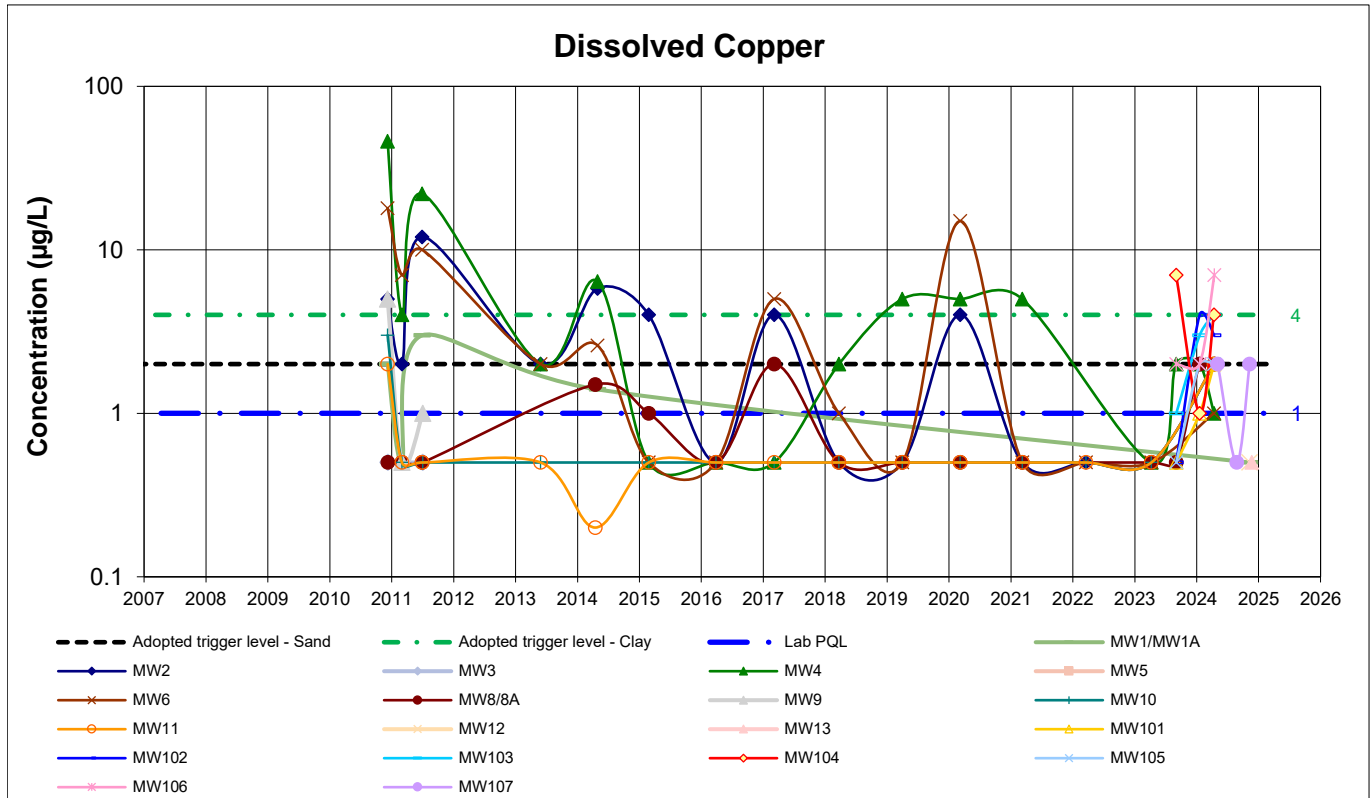

1. Values reported below PQL are plotted as half PQL
2. If a Criteria line is not plotted, there is no criteria

GROUNDWATER QUALITY MONITORING
Tomago Northbank Enterprise Hub
Data Period: 2007 to January 2025

Data set: All data

Project: 39920.09

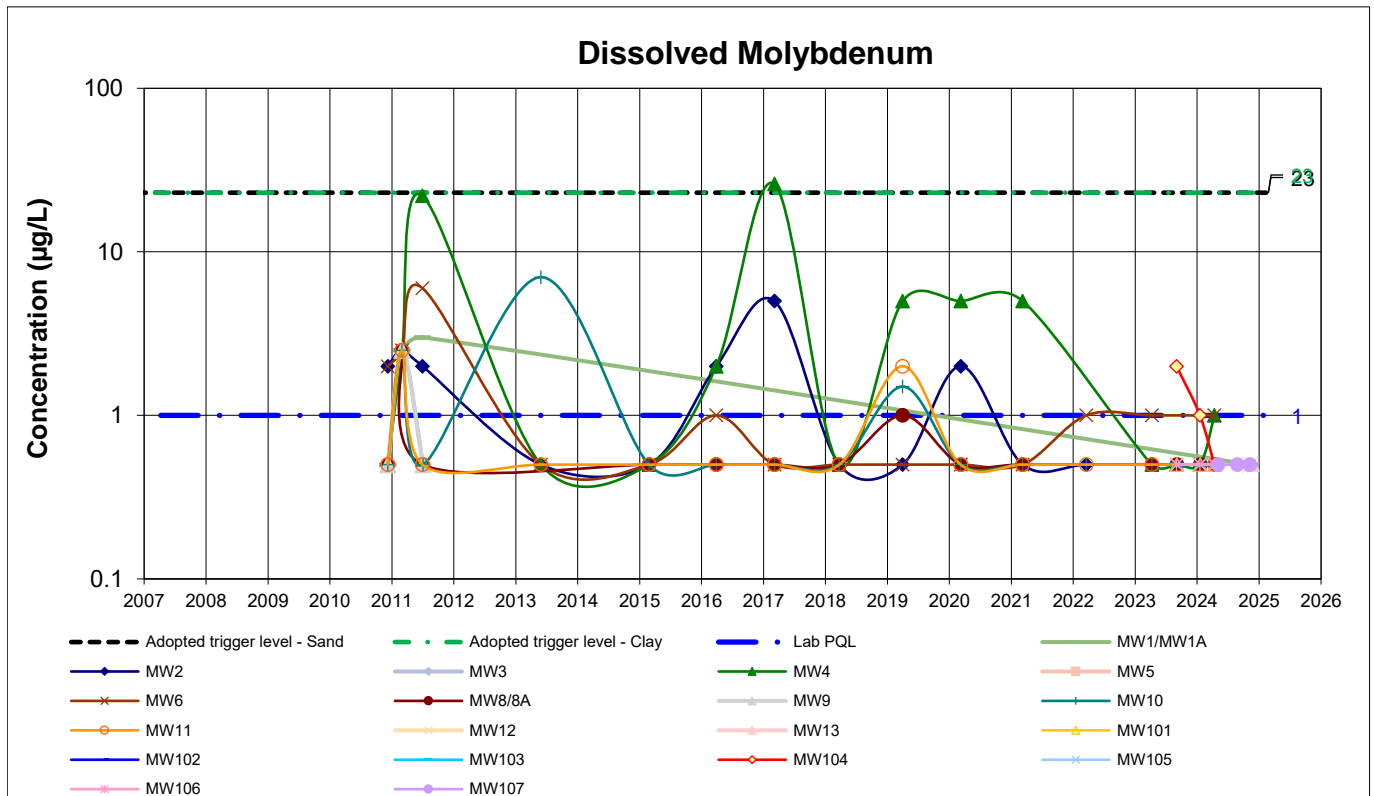
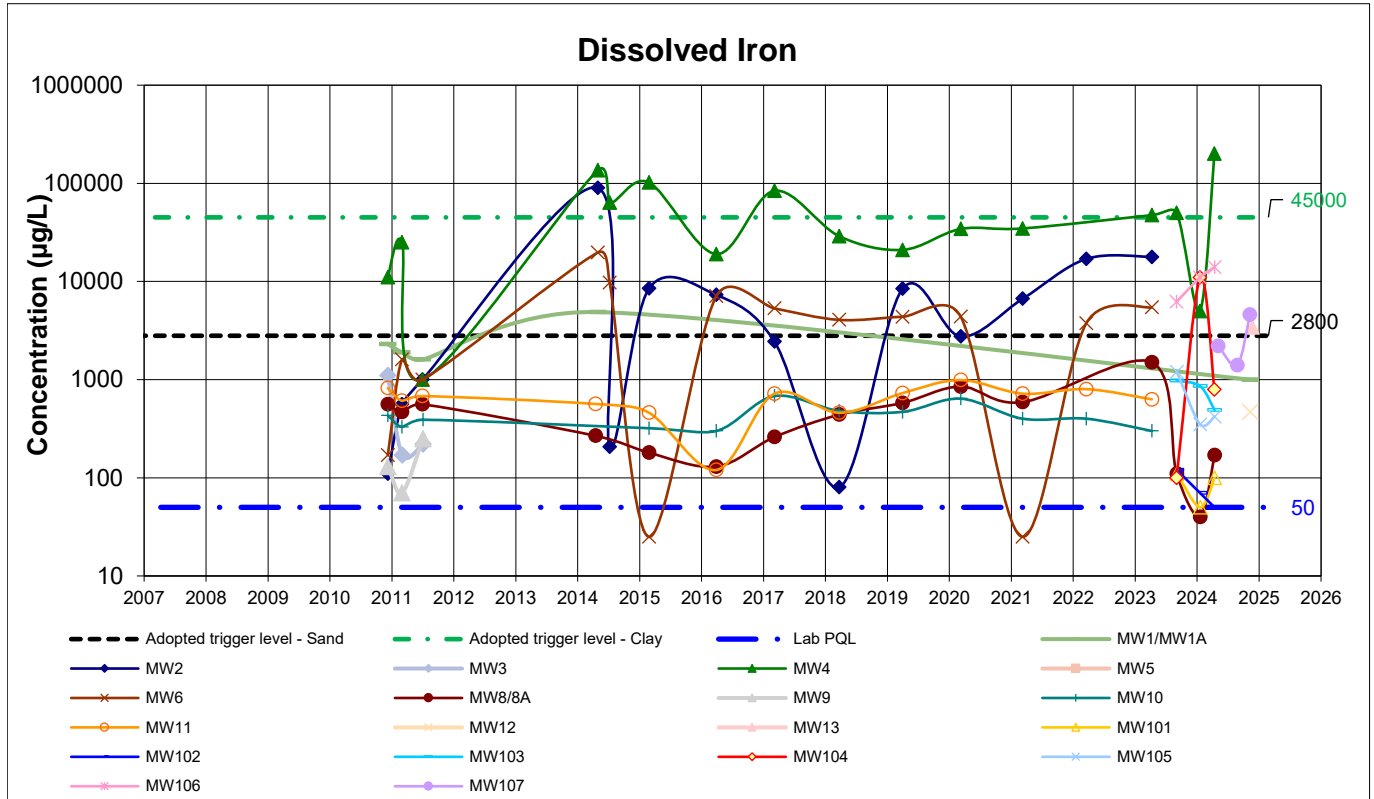

1. Values reported below PQL are plotted as half PQL
 2. If a Criterion line is not plotted, there is no criteria

GROUNDWATER QUALITY MONITORING
Tomago Northbank Enterprise Hub
Data Period: 2007 to January 2025

Data set: All data

Project: 39920.09

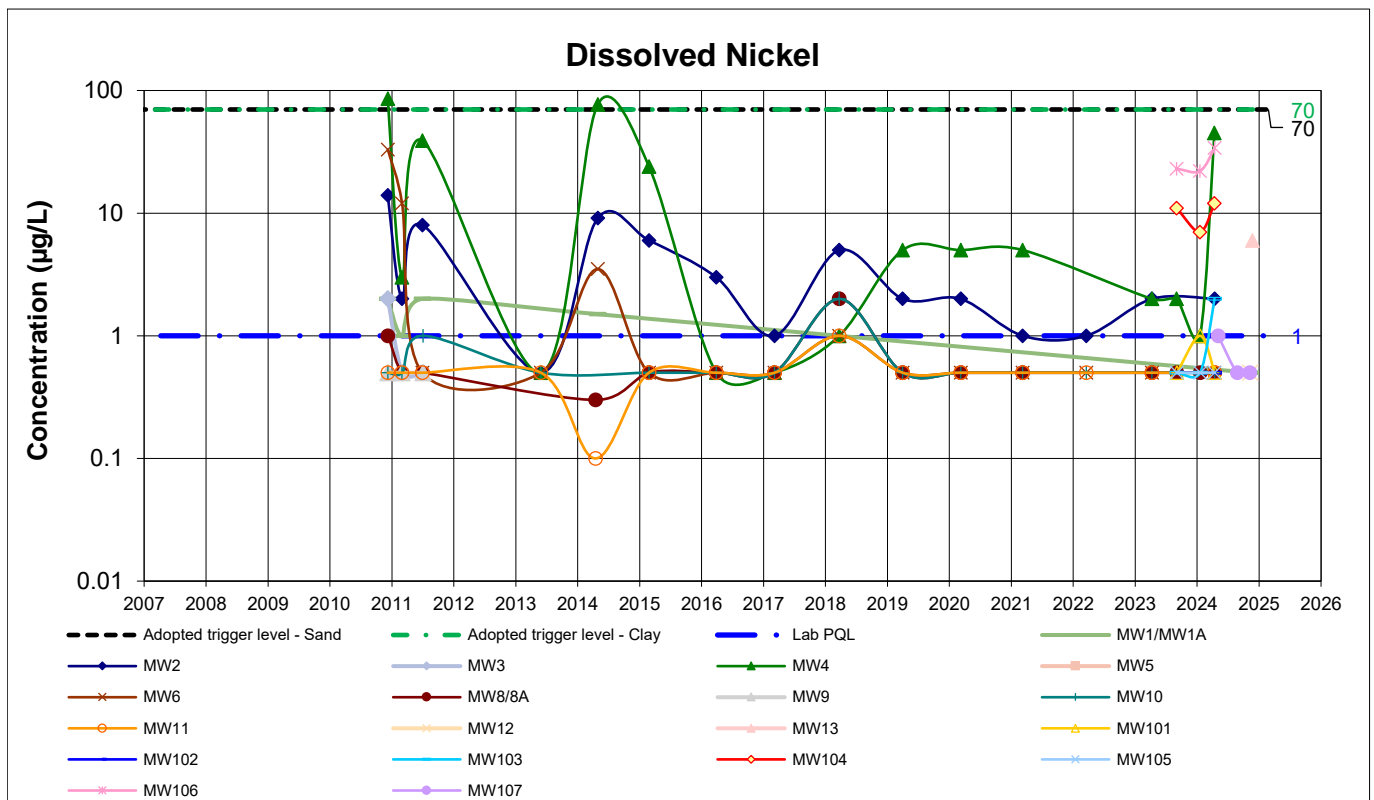
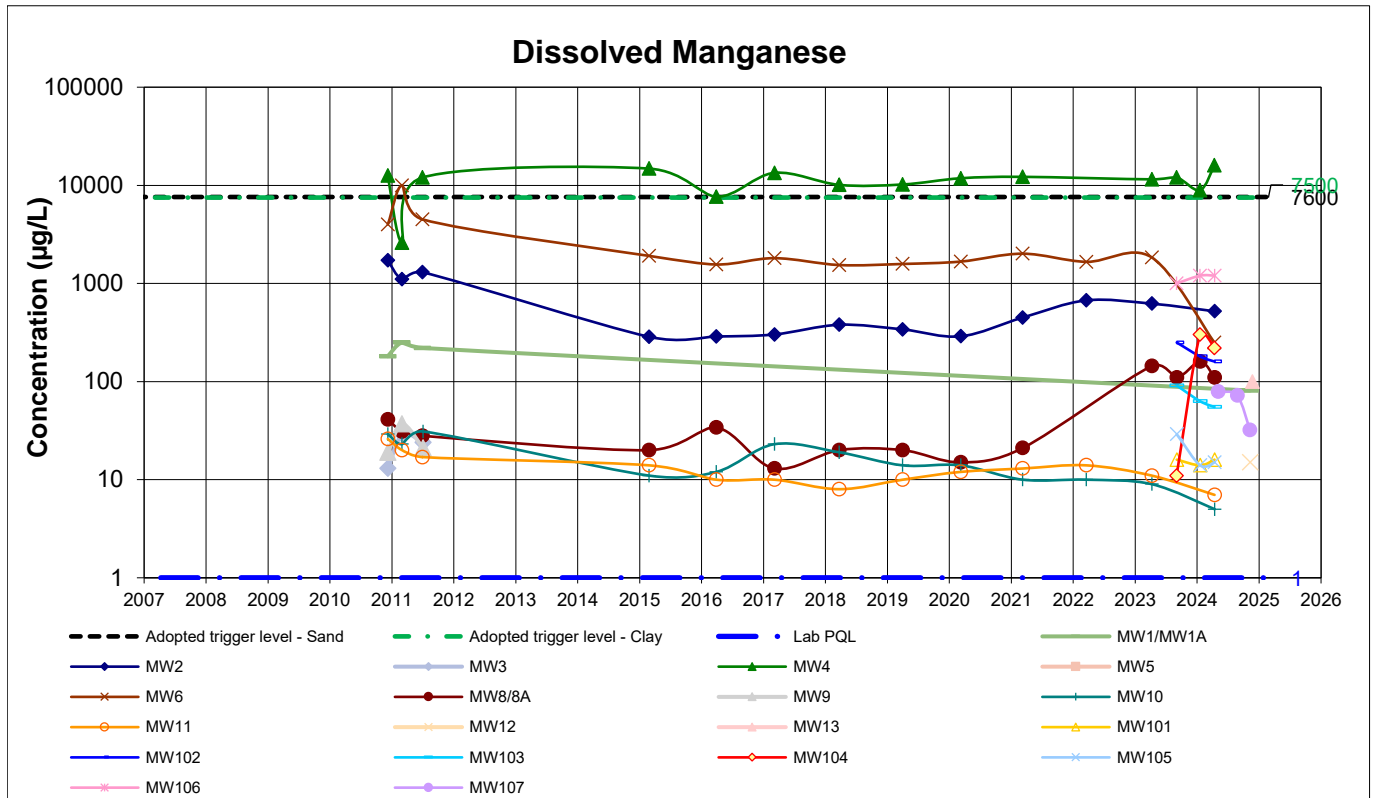

1. Values reported below PQL are plotted as half PQL
 2. If a Criteria line is not plotted, there is no criteria

GROUNDWATER QUALITY MONITORING
Tomago Northbank Enterprise Hub
Data Period: 2007 to January 2025

Data set: All data

Project: 39920.09

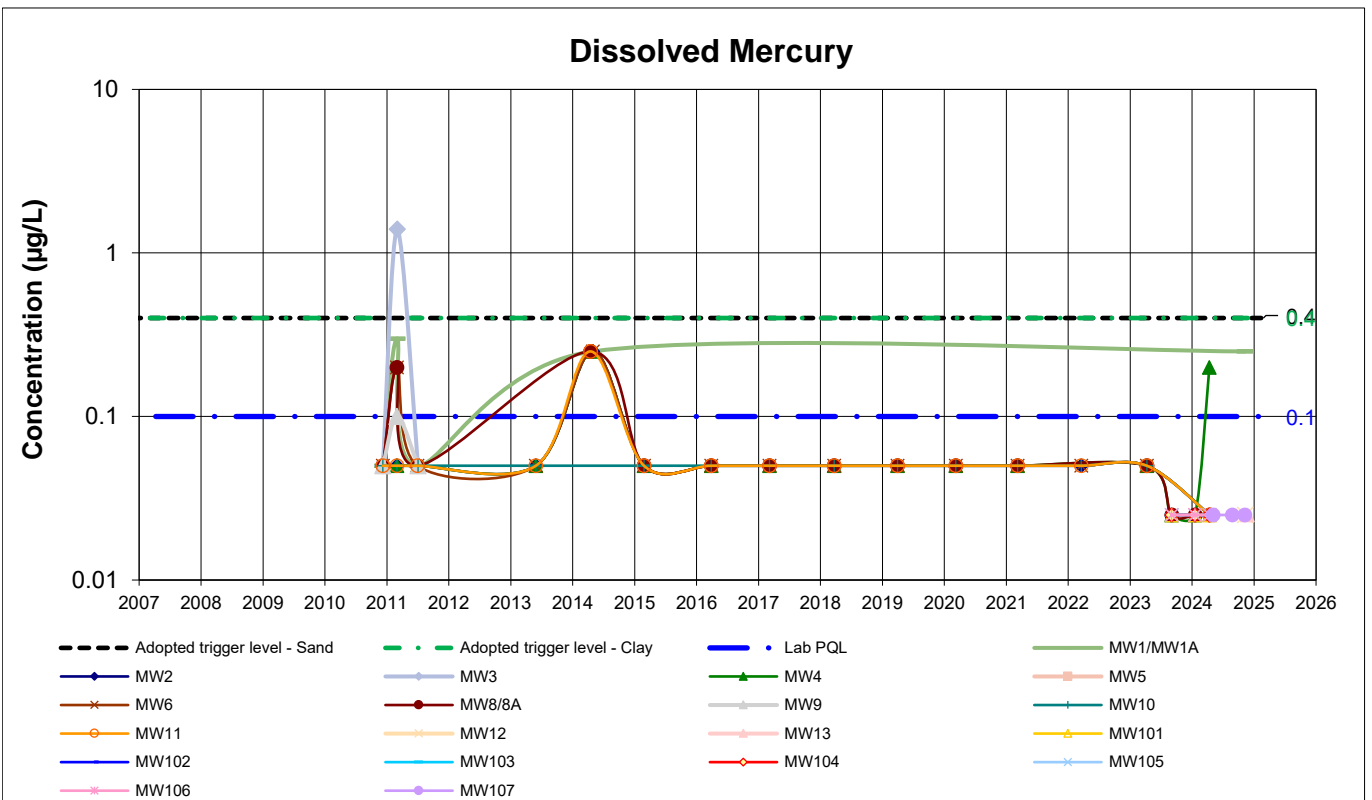
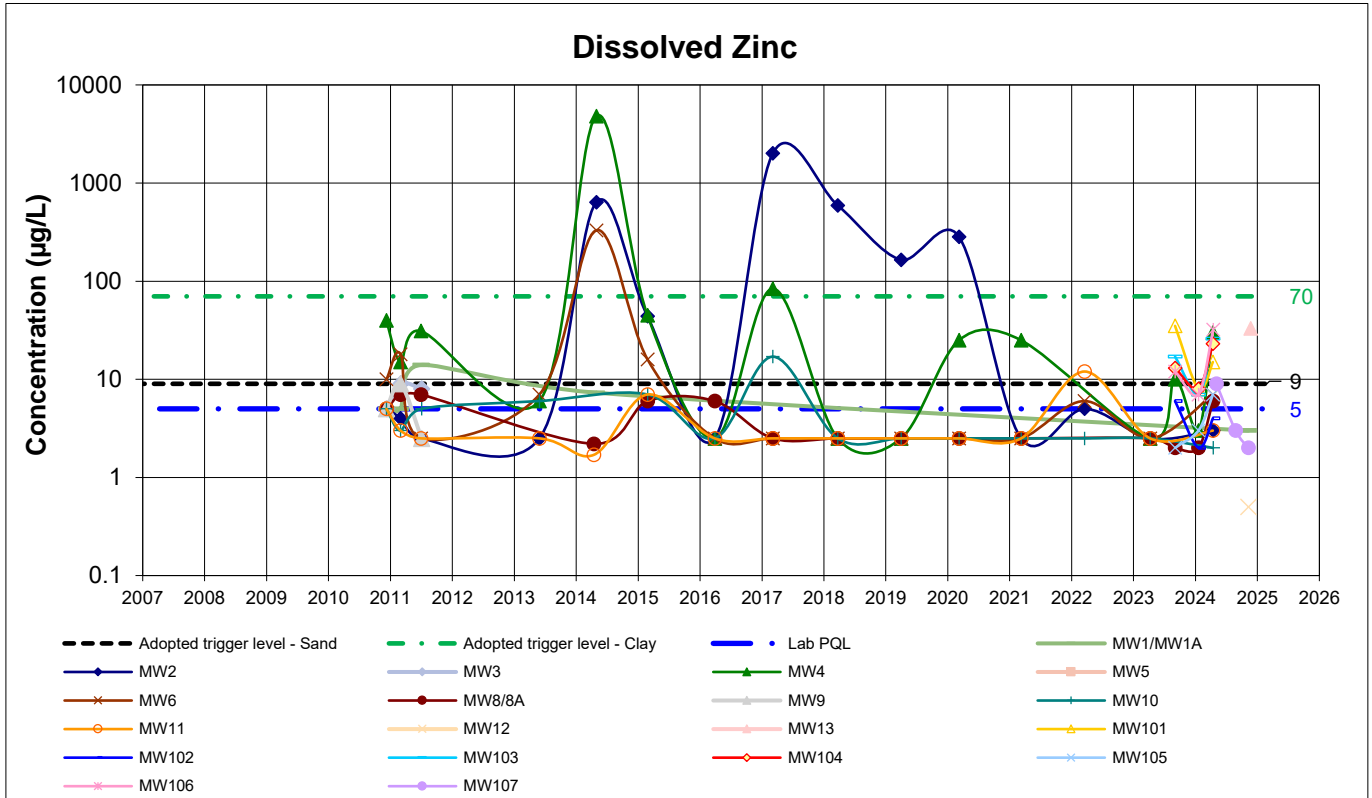

1. Values reported below PQL are plotted as half PQL
2. If a Criterion line is not plotted, there is no criteria

GROUNDWATER QUALITY MONITORING
Tomago Northbank Enterprise Hub
Data Period: 2007 to January 2025

Data set: All data

Project: 39920.09

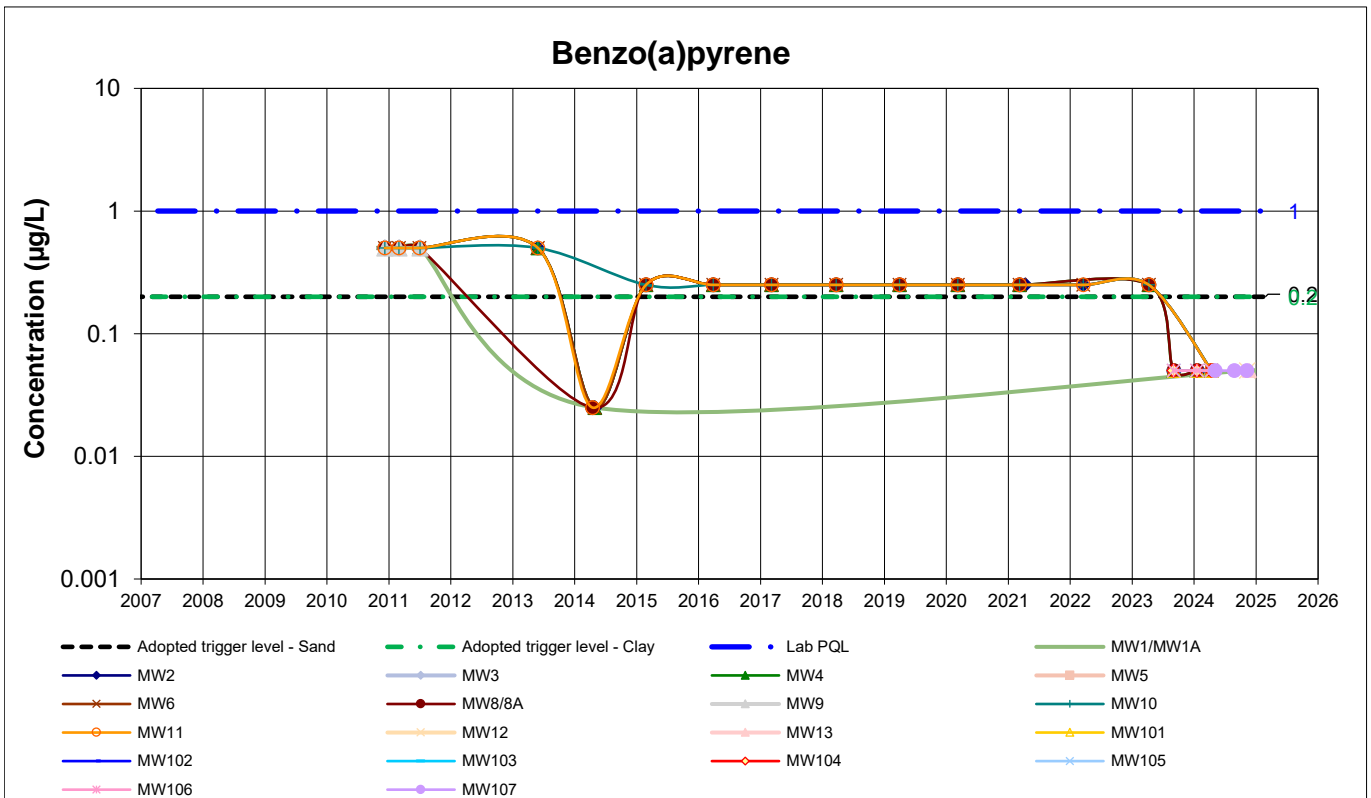
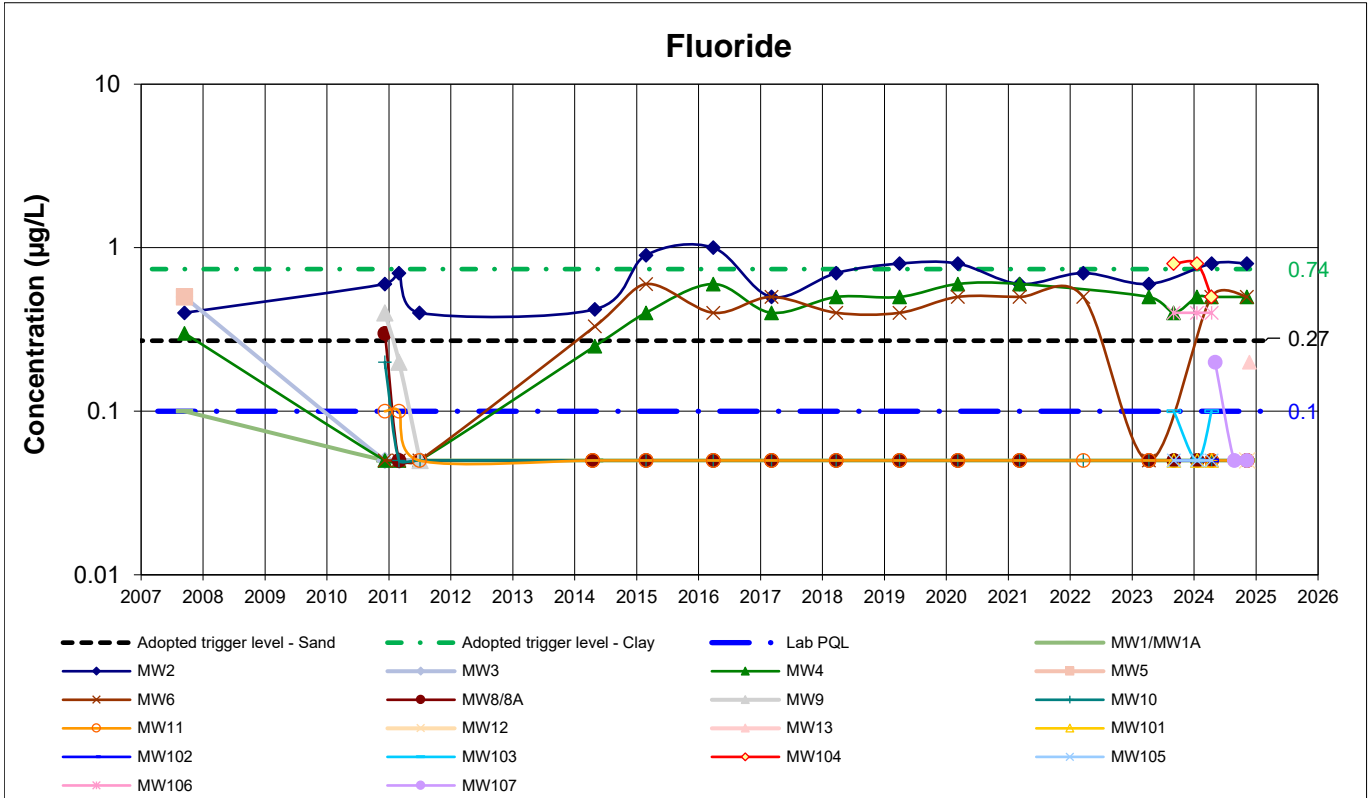

1. Values reported below PQL are plotted as half PQL
 2. If a Criterion line is not plotted, there is no criteria

GROUNDWATER QUALITY MONITORING
Tomago Northbank Enterprise Hub
Data Period: 2007 to January 2025

Data set: All data

Project: 39920.09

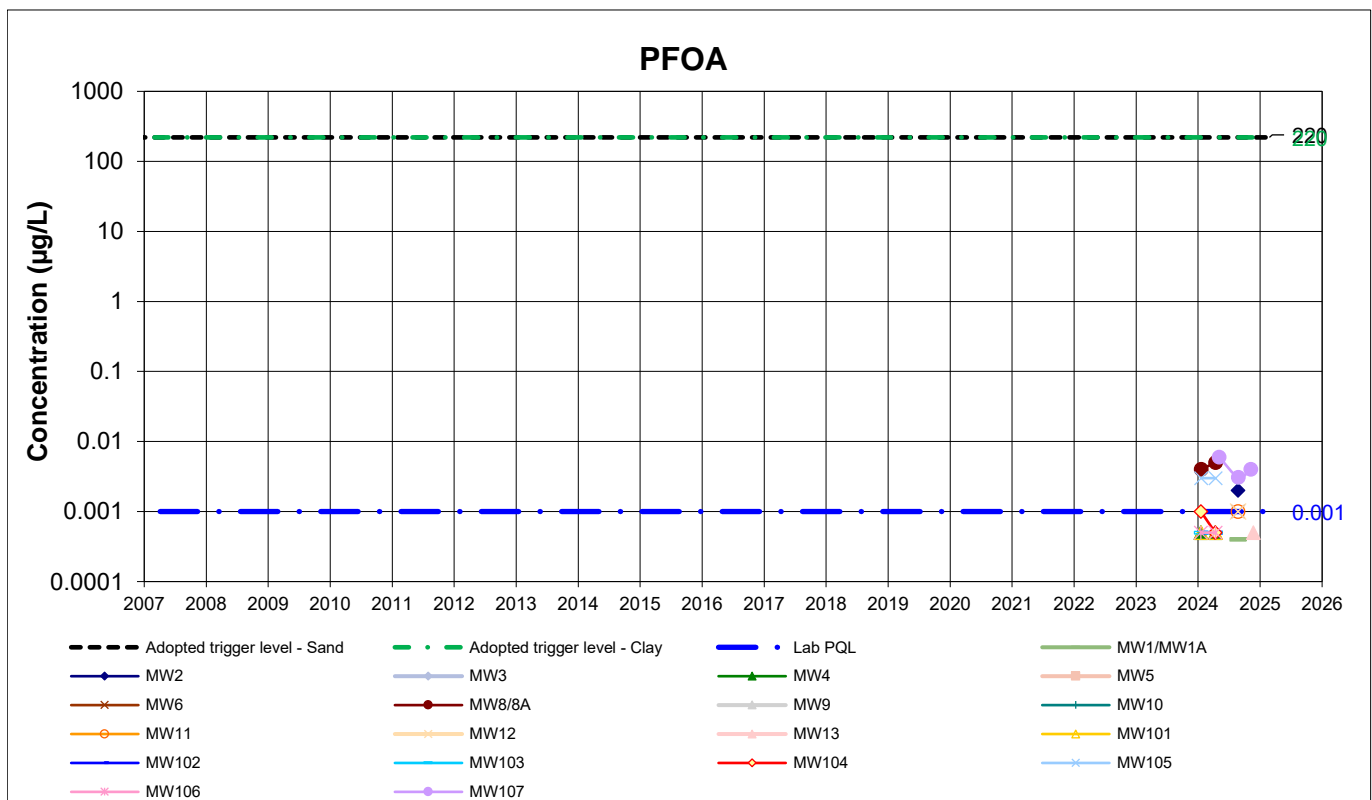
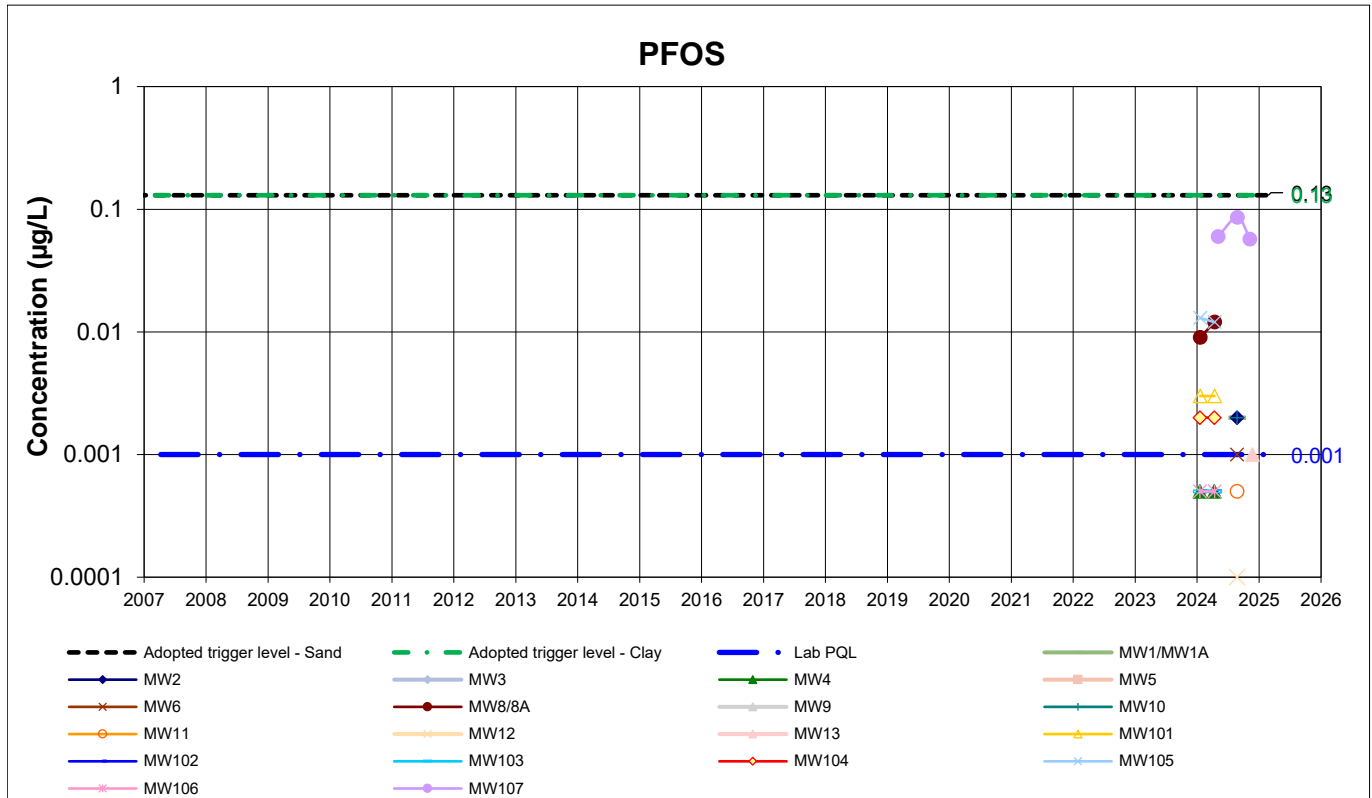

1. Values reported below PQL are plotted as half PQL
 2. If a Criterion line is not plotted, there is no criteria

GROUNDWATER QUALITY MONITORING
Tomago Northbank Enterprise Hub
Data Period: 2007 to January 2025

Data set: All data

Project: 39920.09

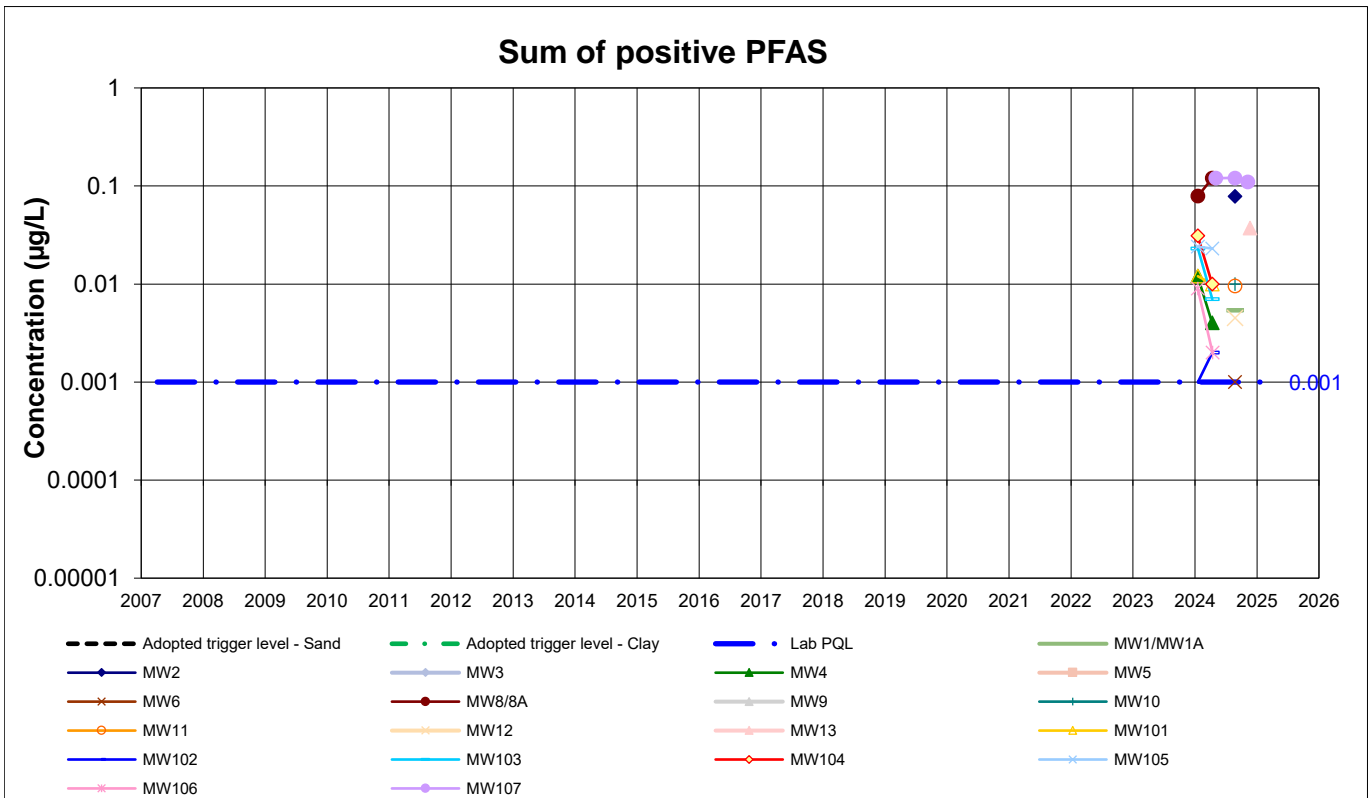
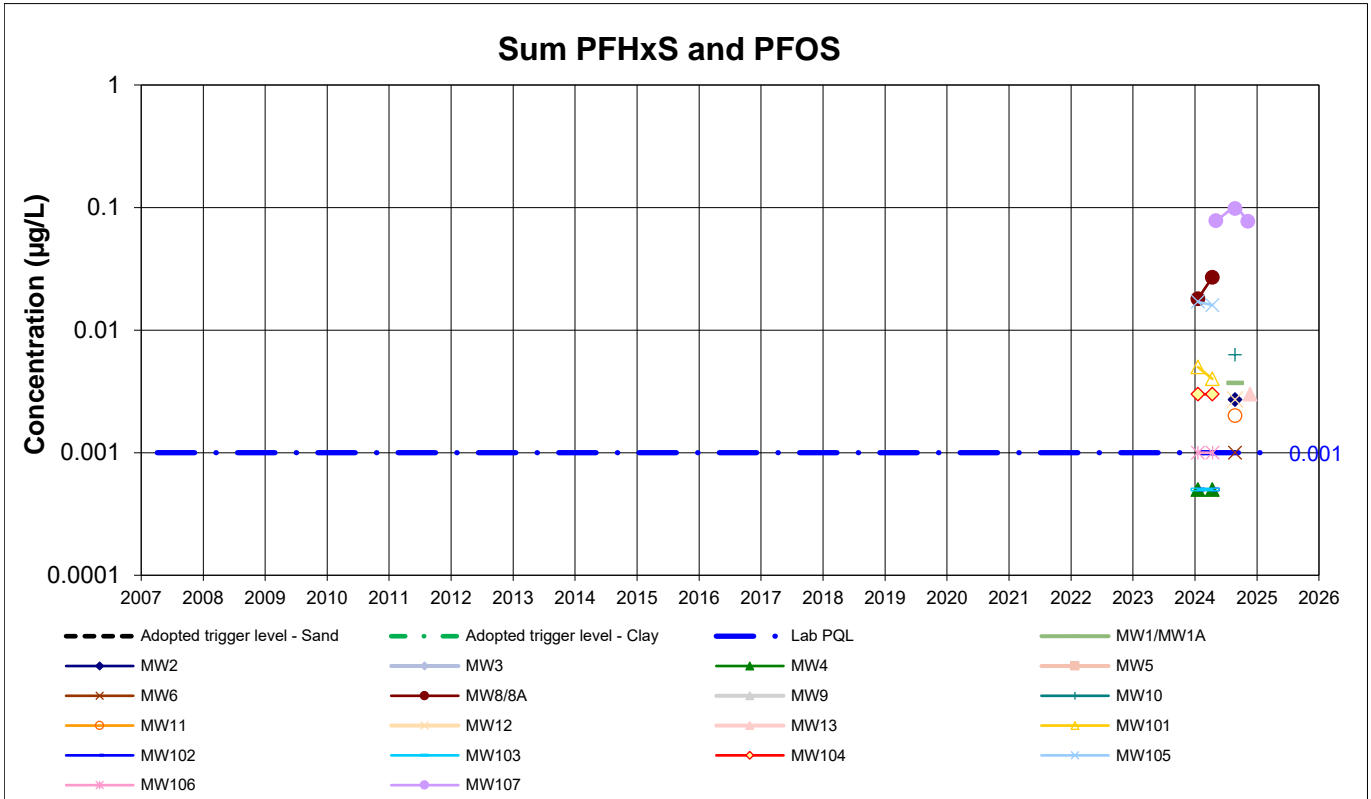

1. Values reported below PQL are plotted as half PQL
2. If a Criteria line is not plotted, there is no criteria

GROUNDWATER QUALITY MONITORING
Tomago Northbank Enterprise Hub
Data Period: 2007 to January 2025

Data set: All data

Project: 39920.09

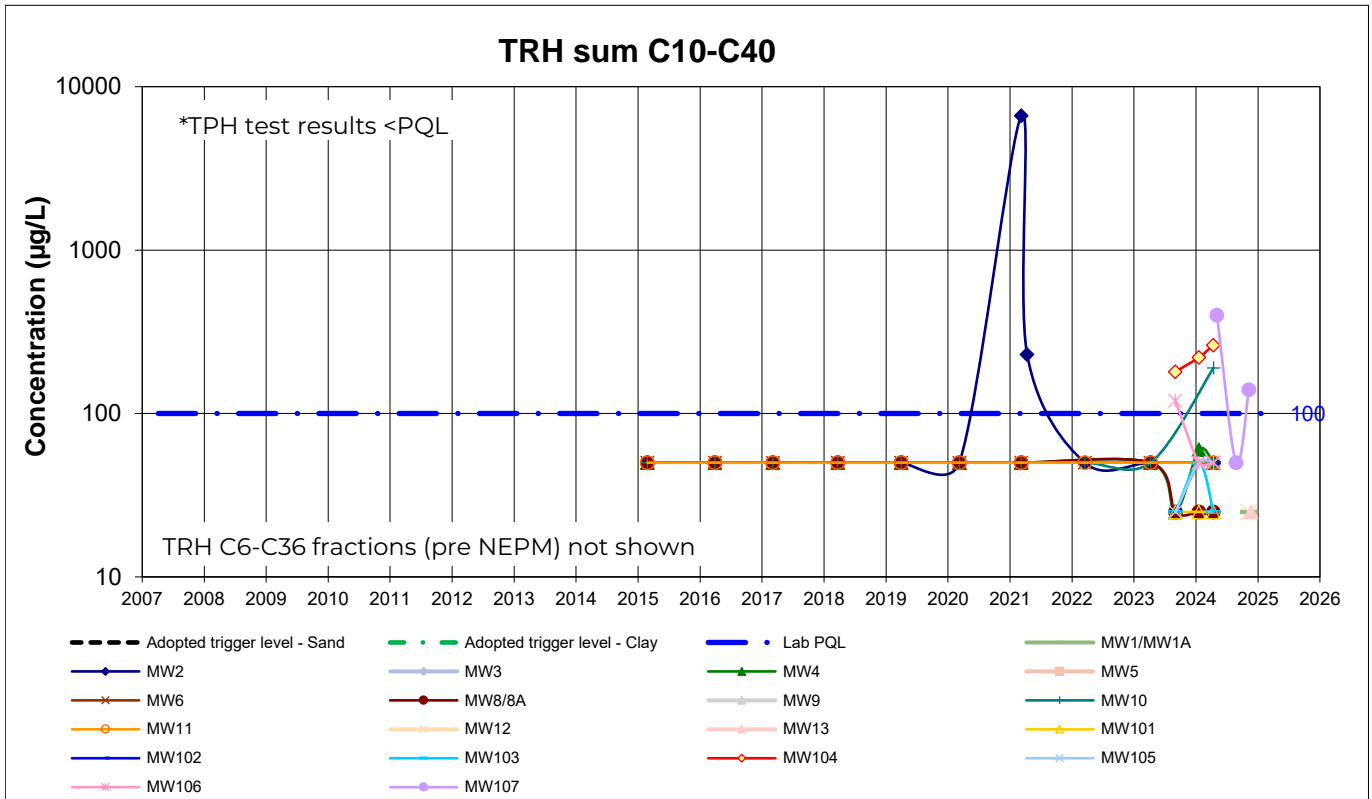

1. Values reported below PQL are plotted as half PQL
2. If a Criterion line is not plotted, there is no criteria

SURFACE WATER QUALITY MONITORING
Tomago Northbank Enterprise Hub
Data Period: 2007 to January 2025

Data set: All data

Project: 39920.09

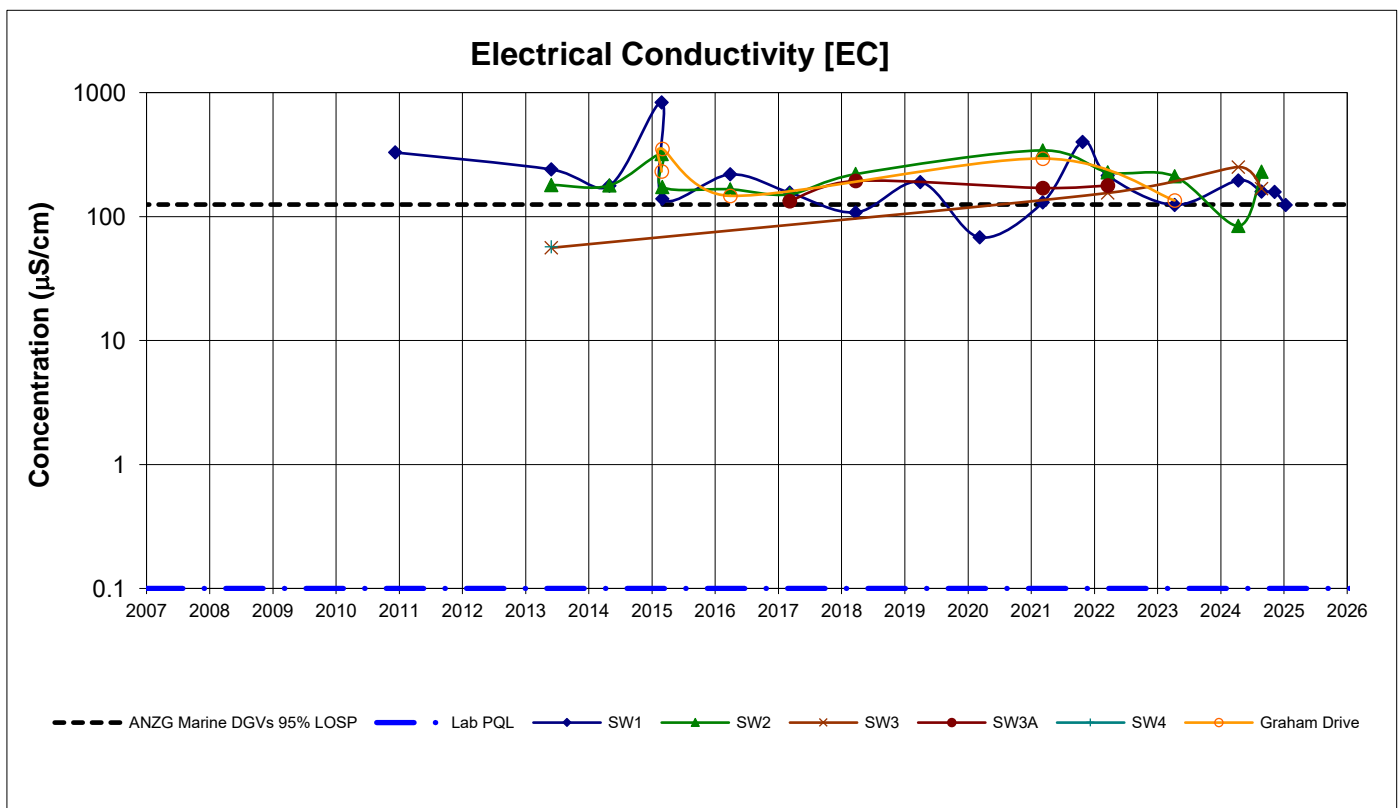
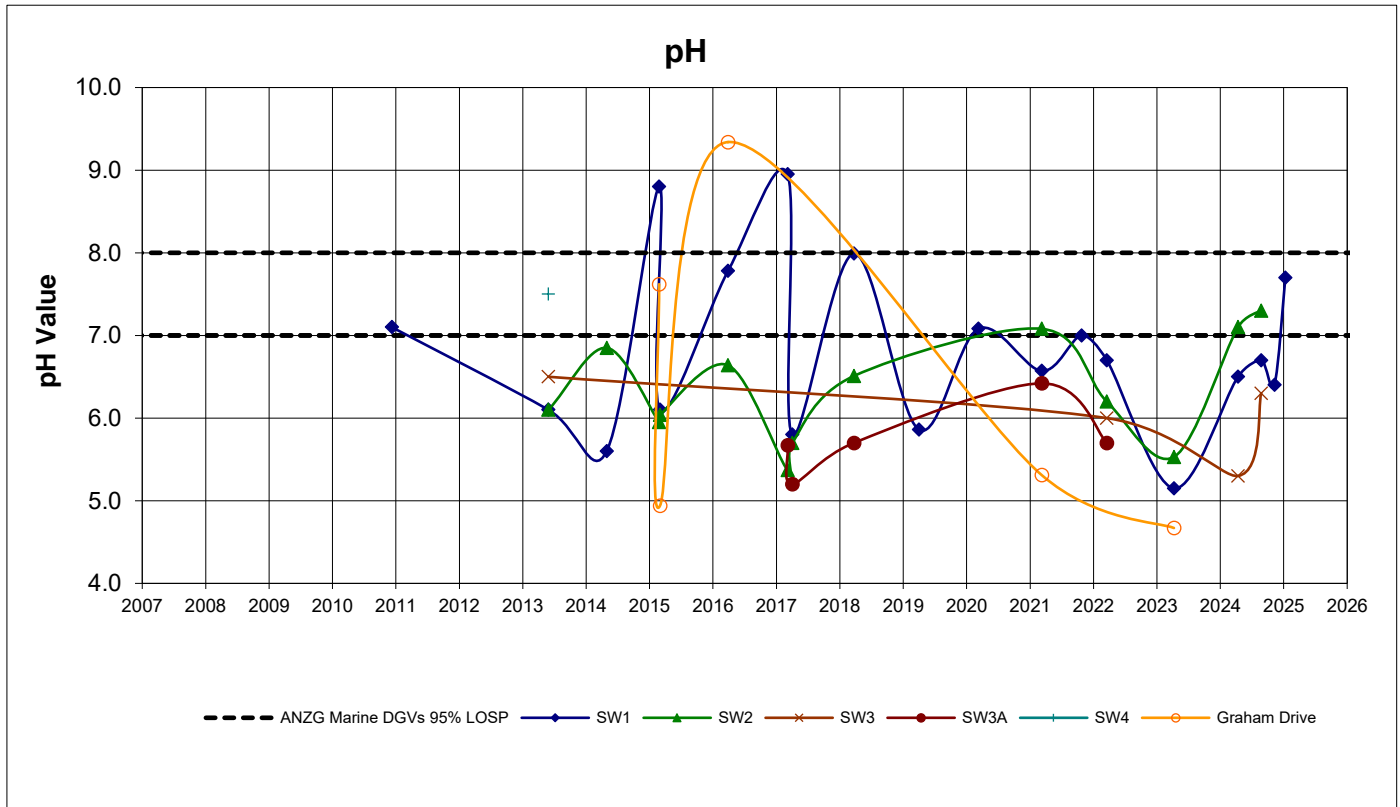

1. Values reported below PQL are plotted as half PQL
2. If a Criterion line is not plotted, there is no published criteria
3. ANZG - Marine water guideline values

SURFACE WATER QUALITY MONITORING
Tomago Northbank Enterprise Hub
Data Period: 2007 to January 2025

Data set: All data

Project: 39920.09

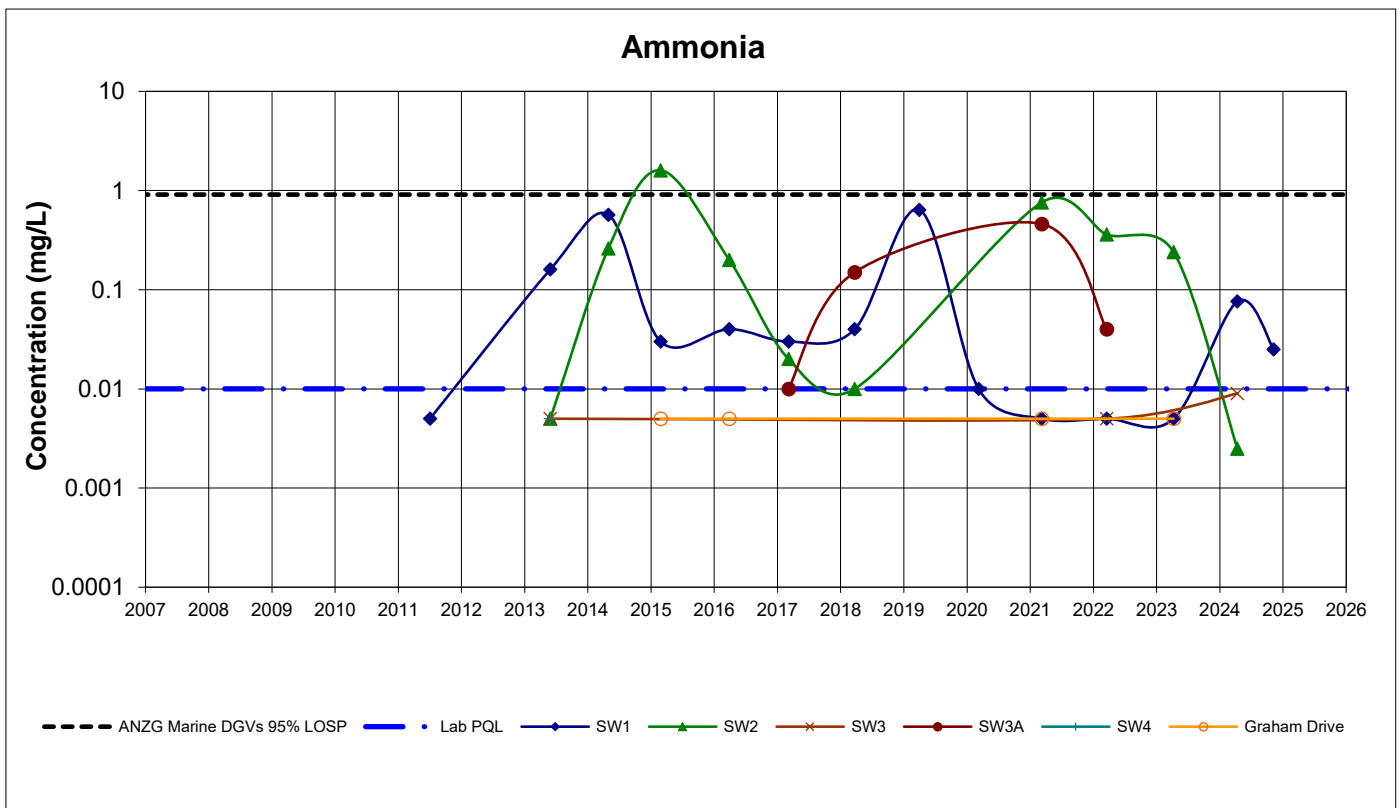
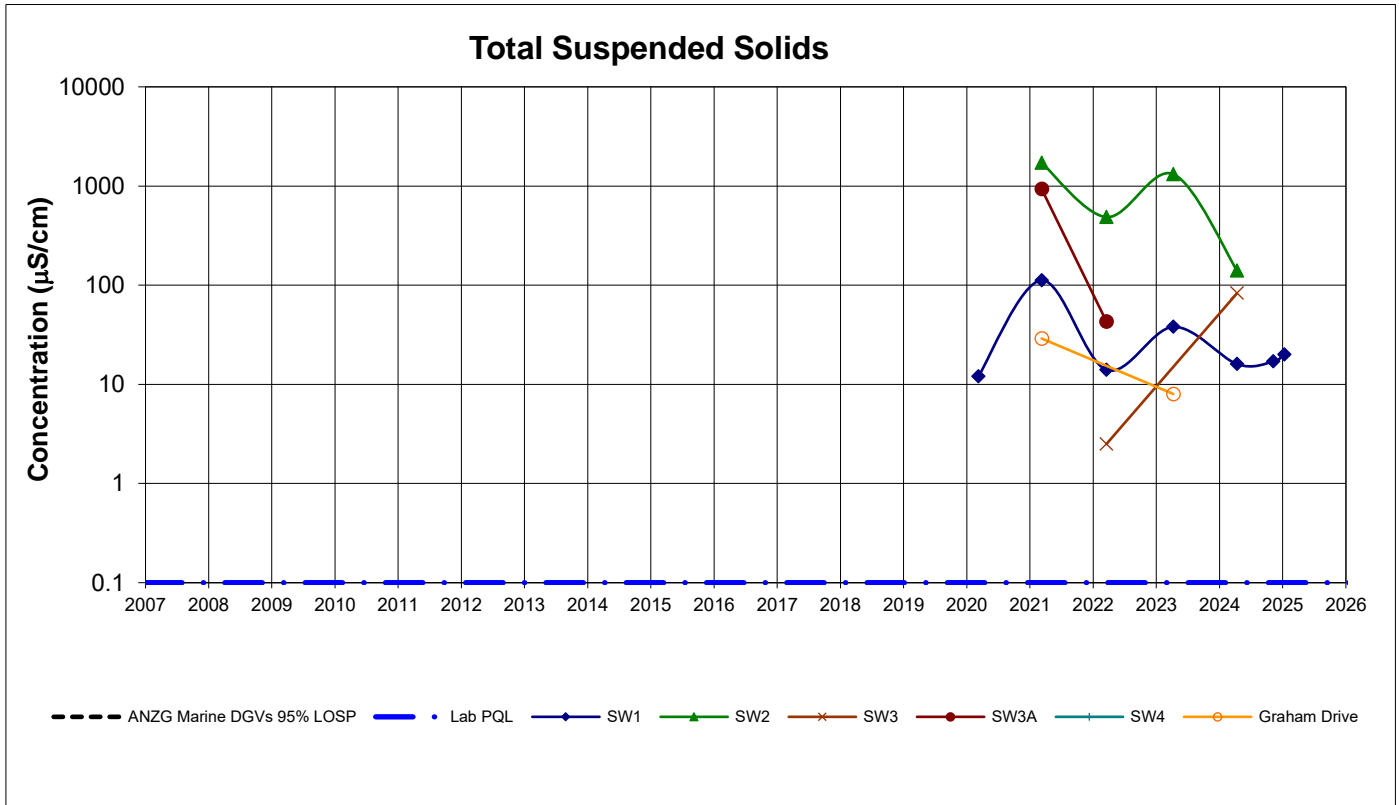

1. Values reported below PQL are plotted as half PQL
2. If a Criterion line is not plotted, there is no published criteria
3. ANZG - Marine water guideline values

SURFACE WATER QUALITY MONITORING
Tomago Northbank Enterprise Hub
Data Period: 2007 to January 2025

Data set: All data

Project: 39920.09

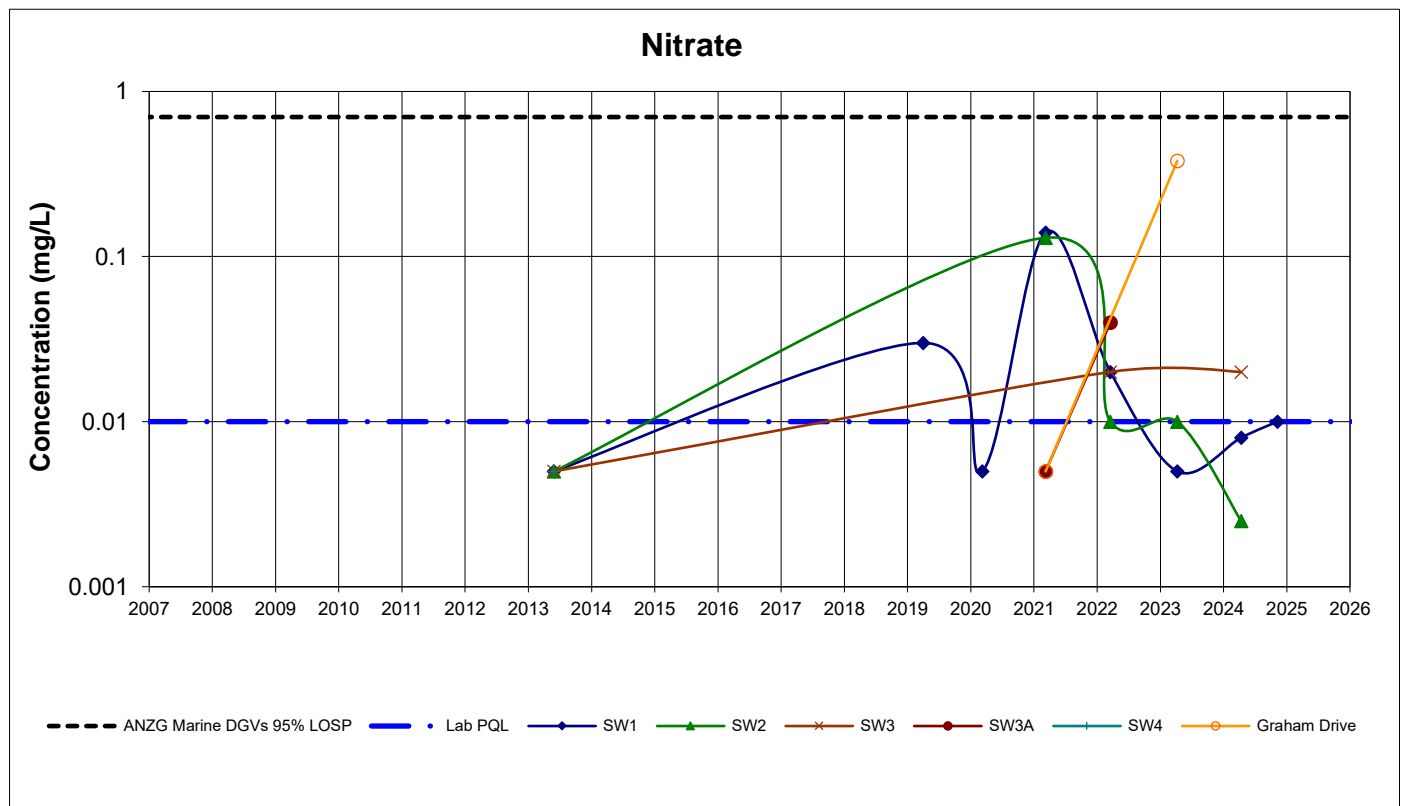
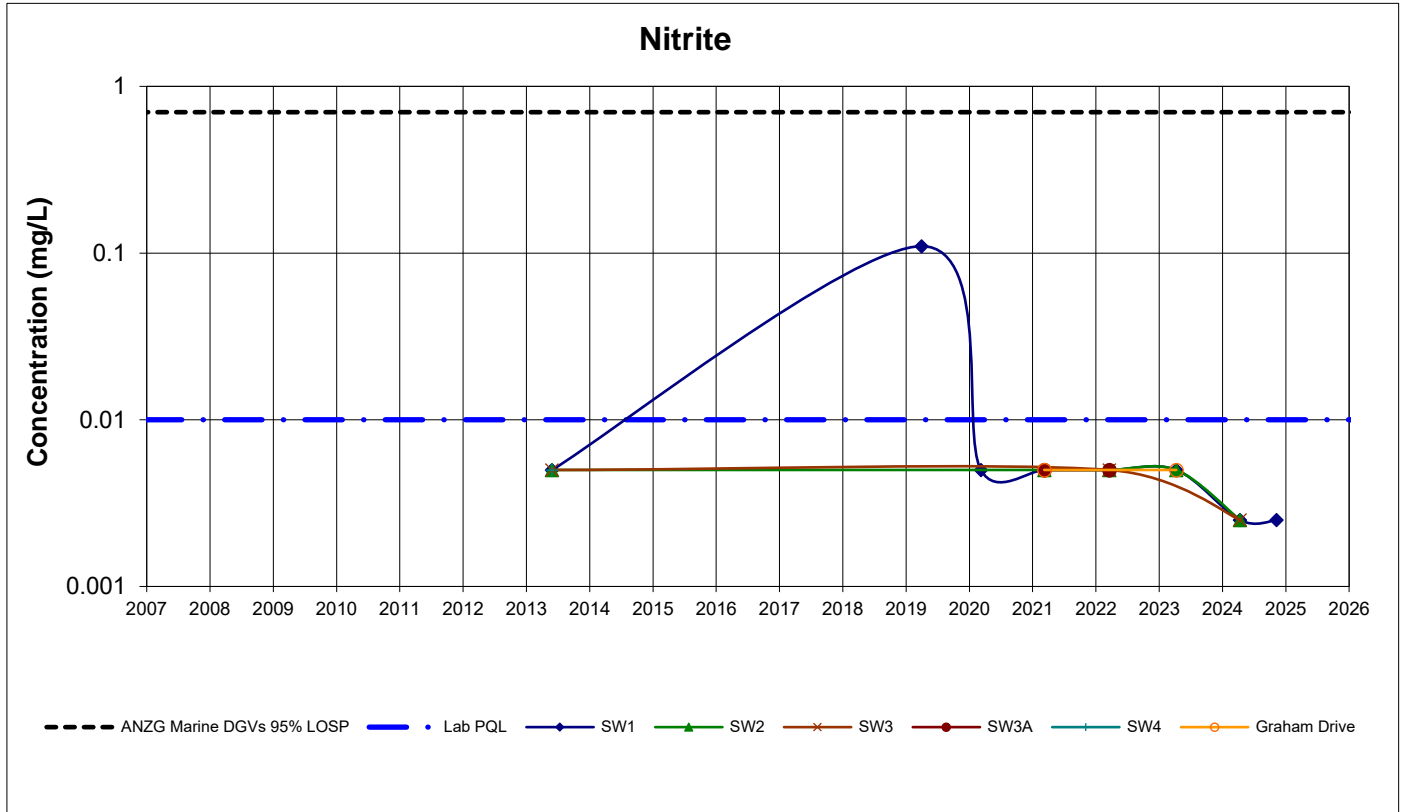

1. Values reported below PQL are plotted as half PQL
2. If a Criterion line is not plotted, there is no published criteria
3. ANZG - Marine water guideline values

SURFACE WATER QUALITY MONITORING
Tomago Northbank Enterprise Hub
Data Period: 2007 to January 2025

Data set: All data

Project: 39920.09

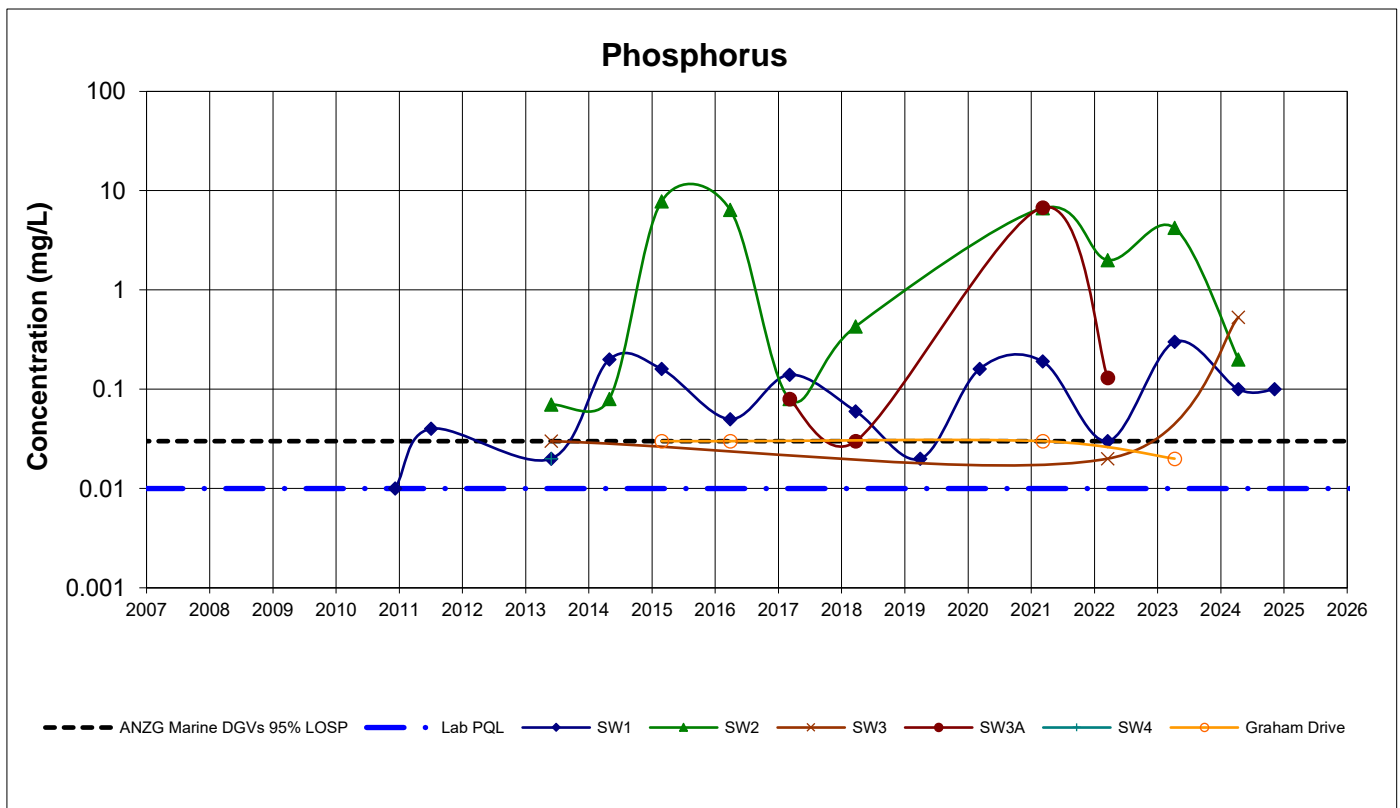
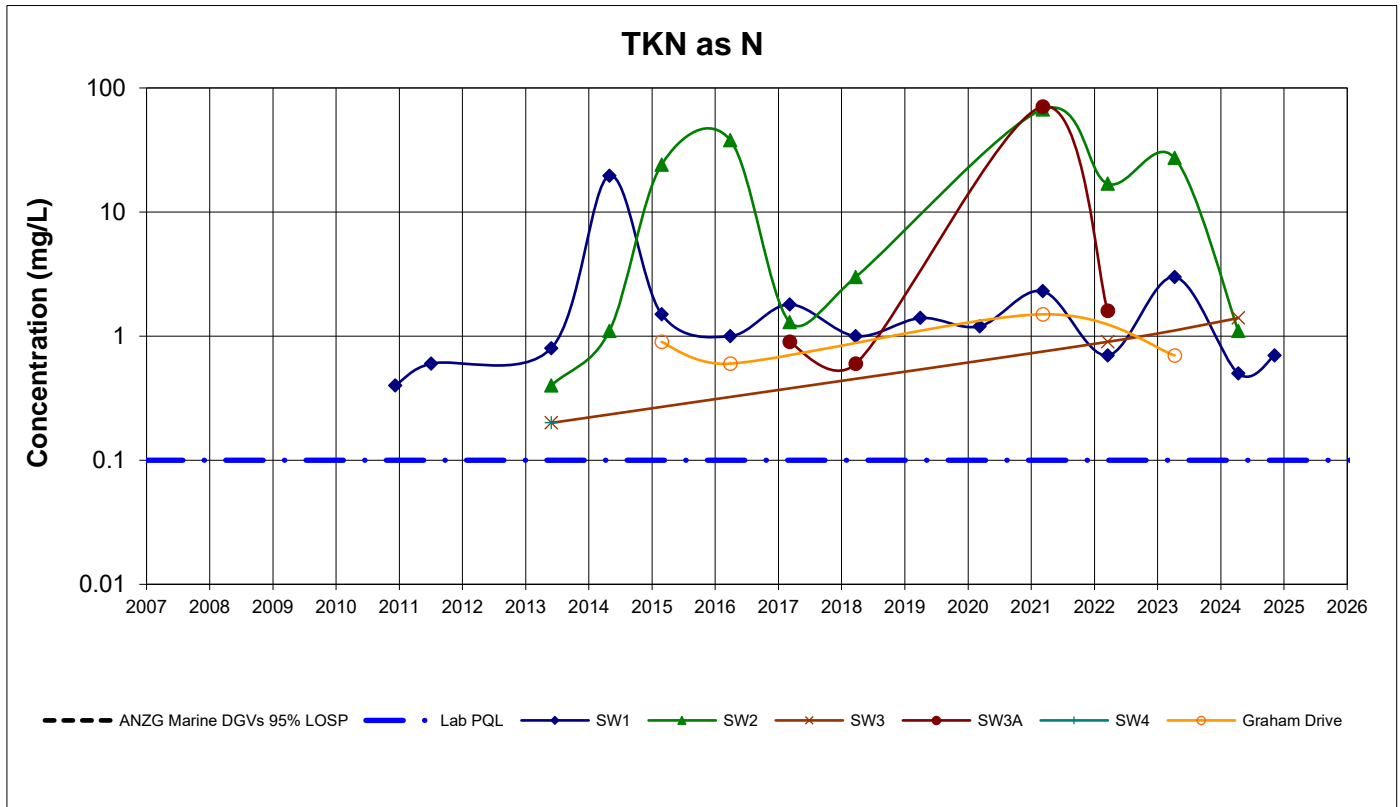

1. Values reported below PQL are plotted as half PQL
2. If a Criterion line is not plotted, there is no published criteria
3. ANZG - Marine water guideline values

SURFACE WATER QUALITY MONITORING
Tomago Northbank Enterprise Hub
Data Period: 2007 to January 2025

Data set: All data

Project: 39920.09

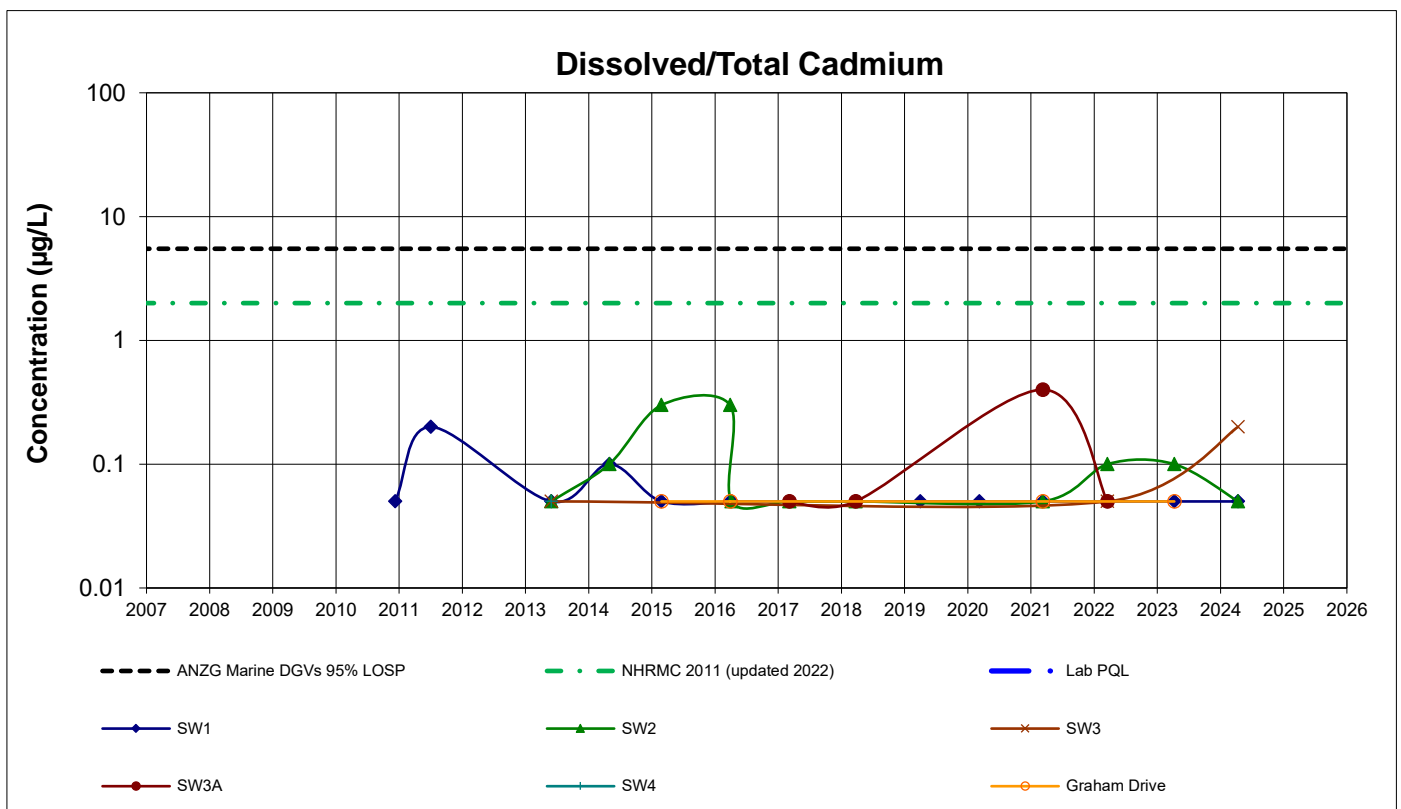
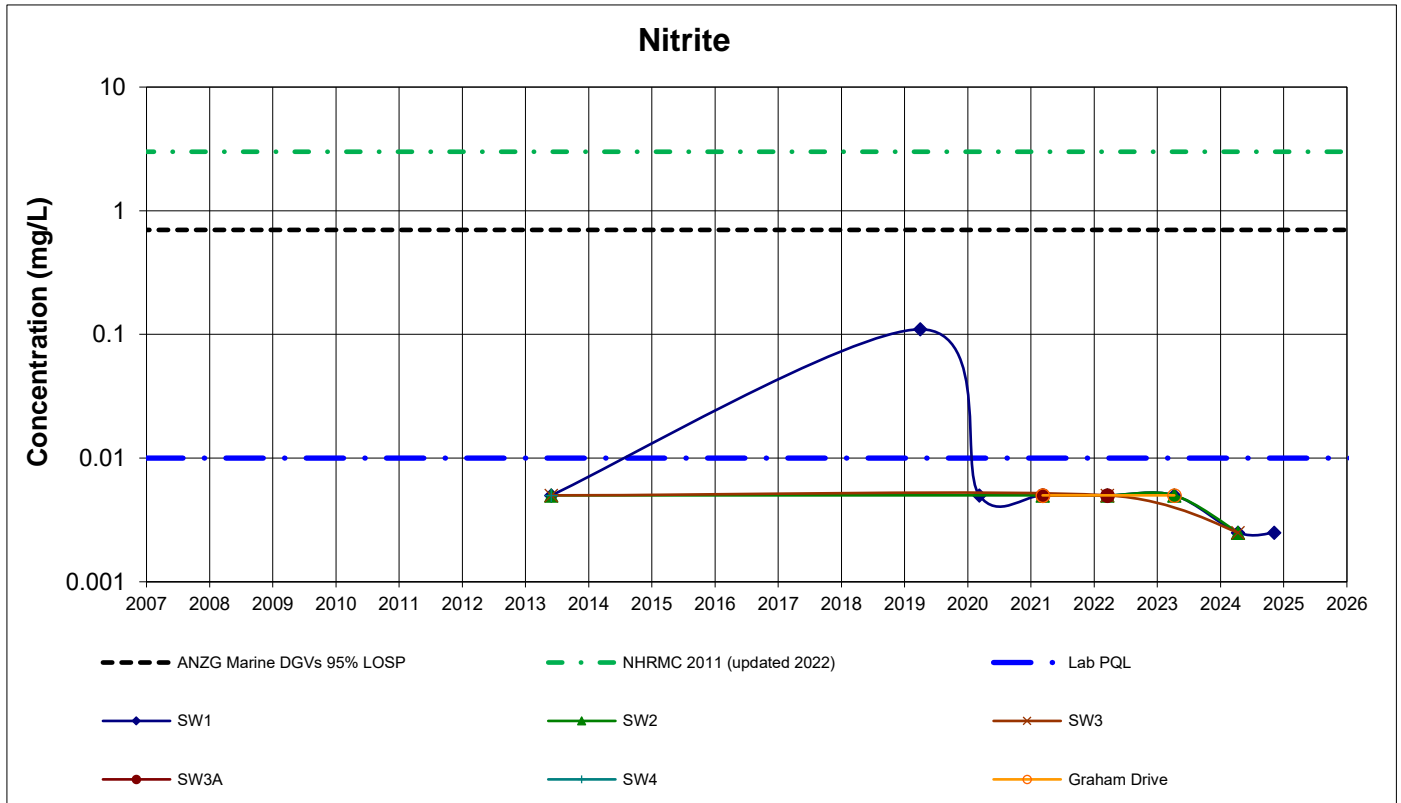

1. Values reported below PQL are plotted as half PQL
2. If a Criterion line is not plotted, there is no published criteria
3. ANZG - Marine water guideline values

SURFACE WATER QUALITY MONITORING
Tomago Northbank Enterprise Hub
Data Period: 2007 to January 2025

Data set: All data

Project: 39920.09

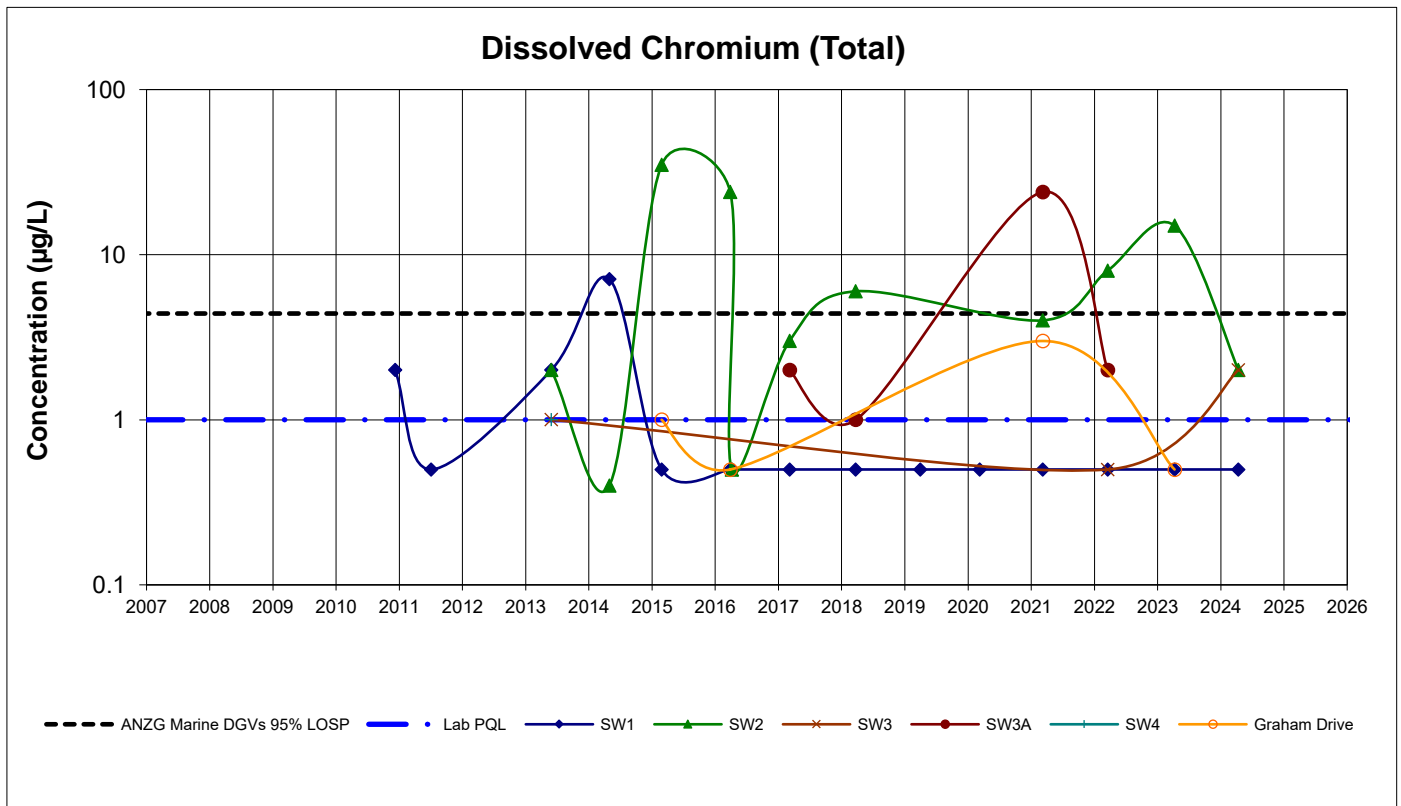
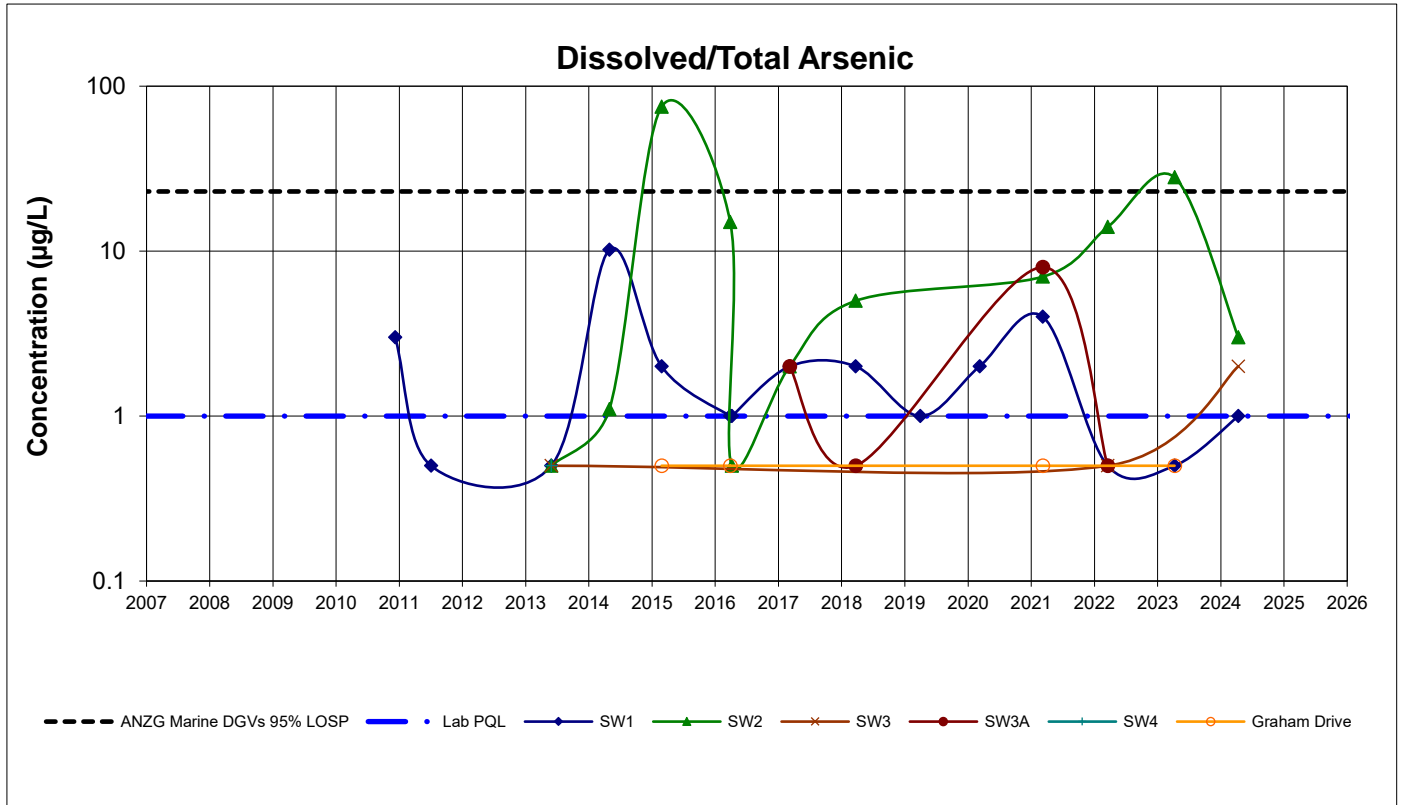

1. Values reported below PQL are plotted as half PQL
2. If a Criterion line is not plotted, there is no published criteria
3. ANZG - Marine water guideline values

SURFACE WATER QUALITY MONITORING
Tomago Northbank Enterprise Hub
Data Period: 2007 to January 2025

Data set: All data

Project: 39920.09

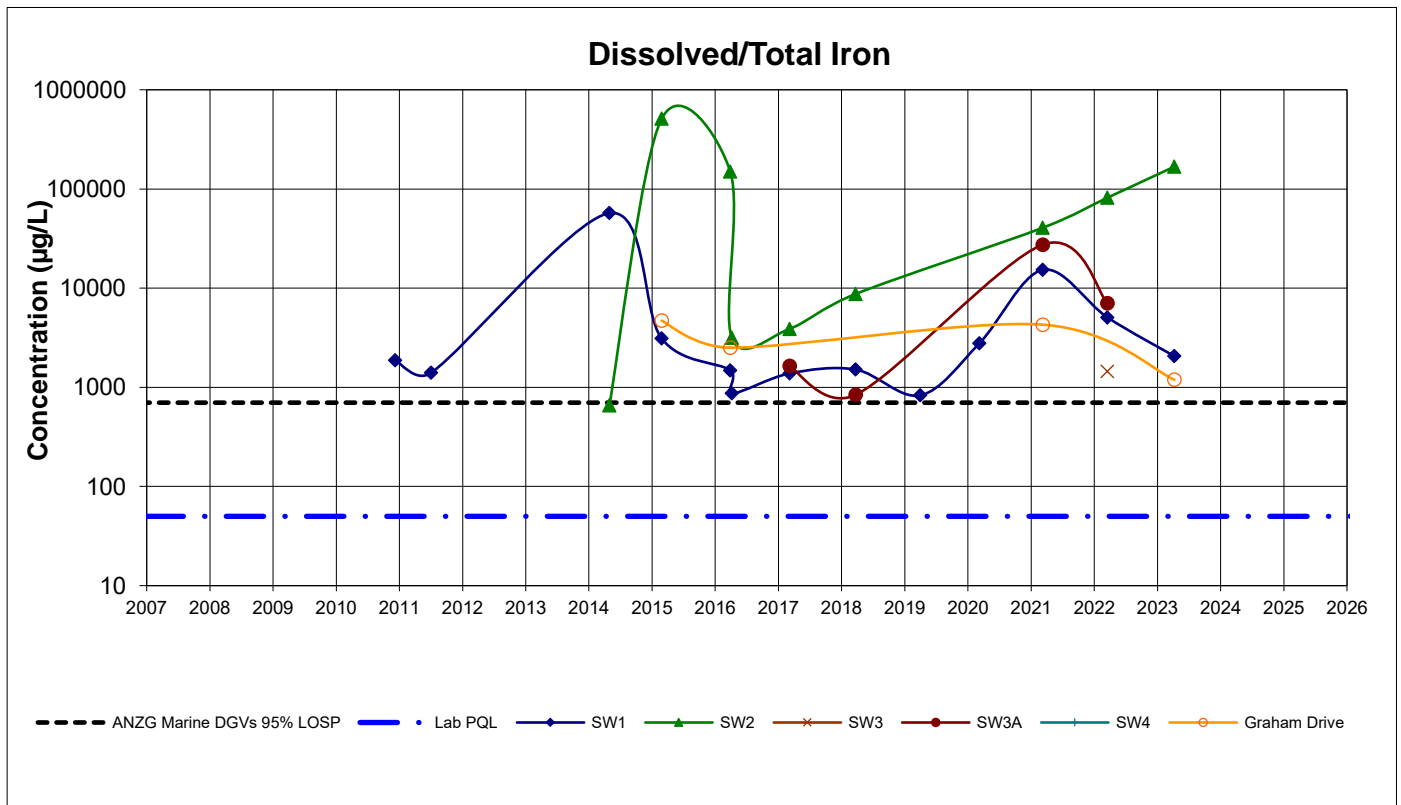
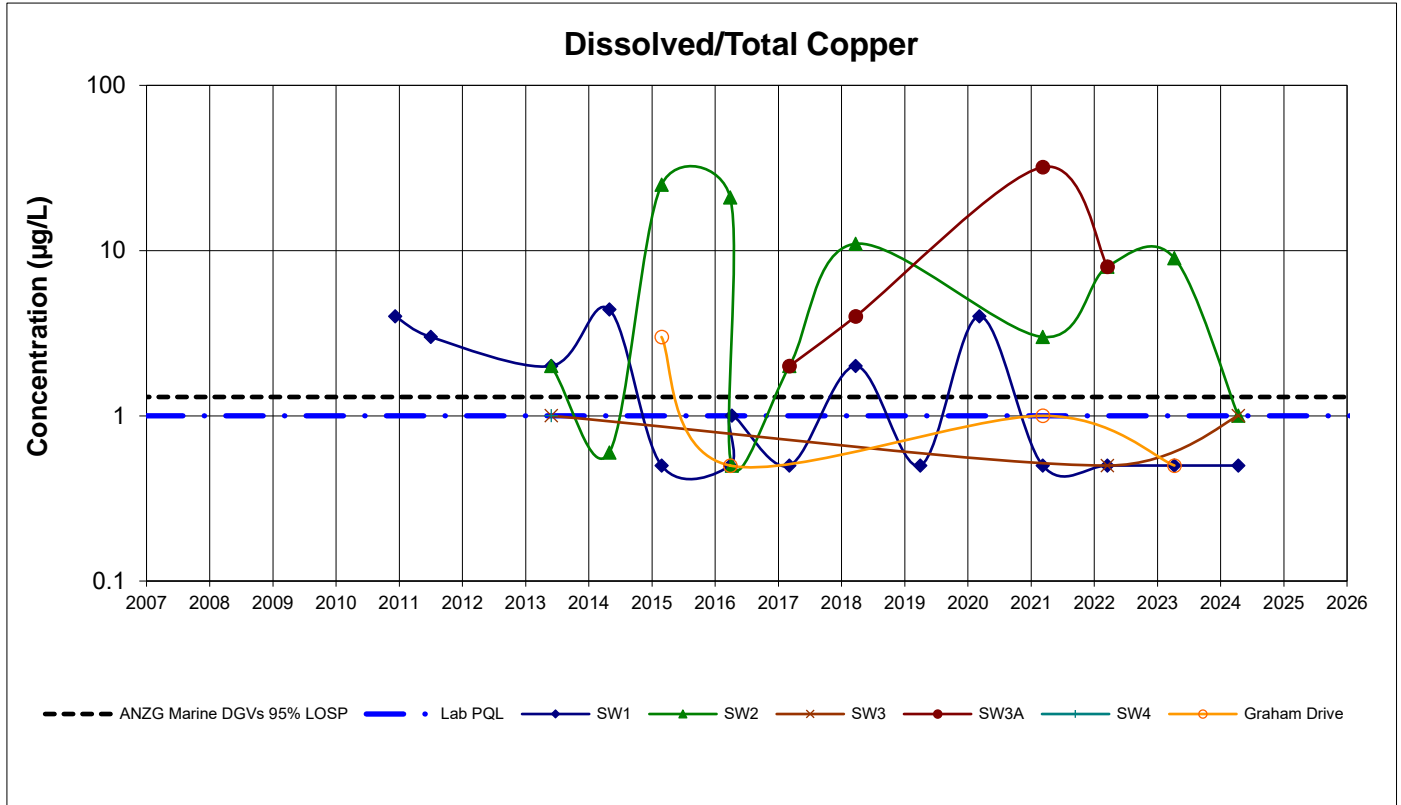

1. Values reported below PQL are plotted as half PQL
2. If a Criterion line is not plotted, there is no published criteria
3. ANZG - Marine water guideline values

SURFACE WATER QUALITY MONITORING
Tomago Northbank Enterprise Hub
Data Period: 2007 to January 2025

Data set: All data

Project: 39920.09

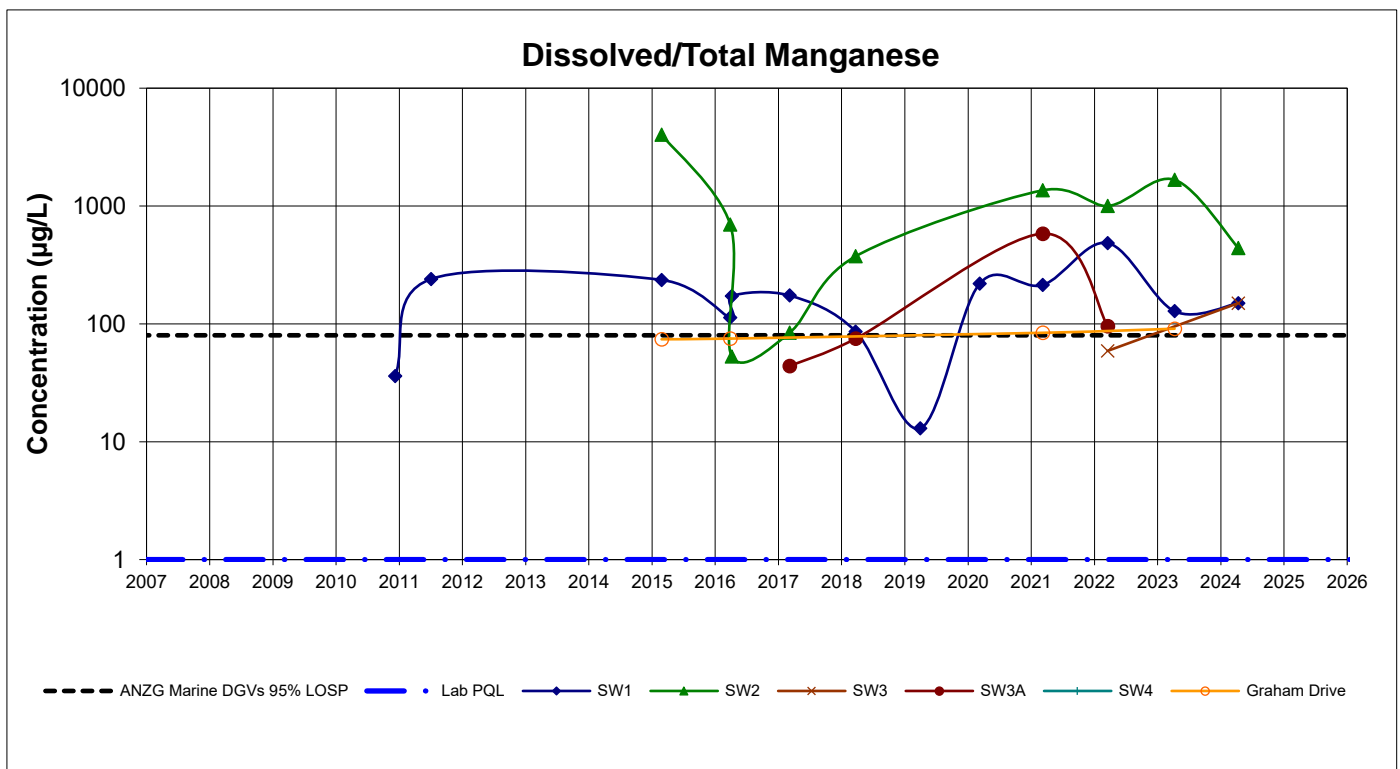
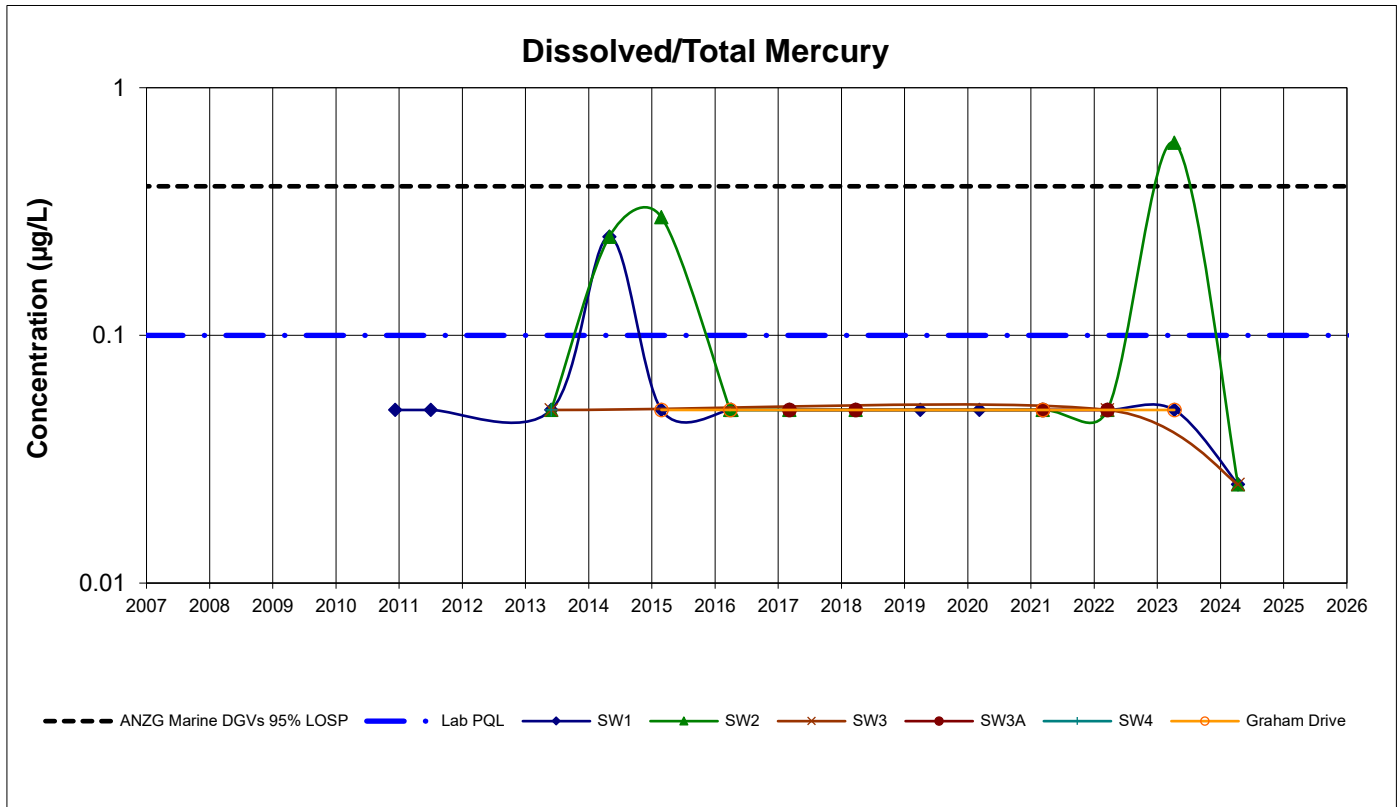

1. Values reported below PQL are plotted as half PQL
2. If a Criterion line is not plotted, there is no published criteria
3. ANZG - Marine water guideline values

SURFACE WATER QUALITY MONITORING
Tomago Northbank Enterprise Hub
Data Period: 2007 to January 2025

Data set: All data

Project: 39920.09

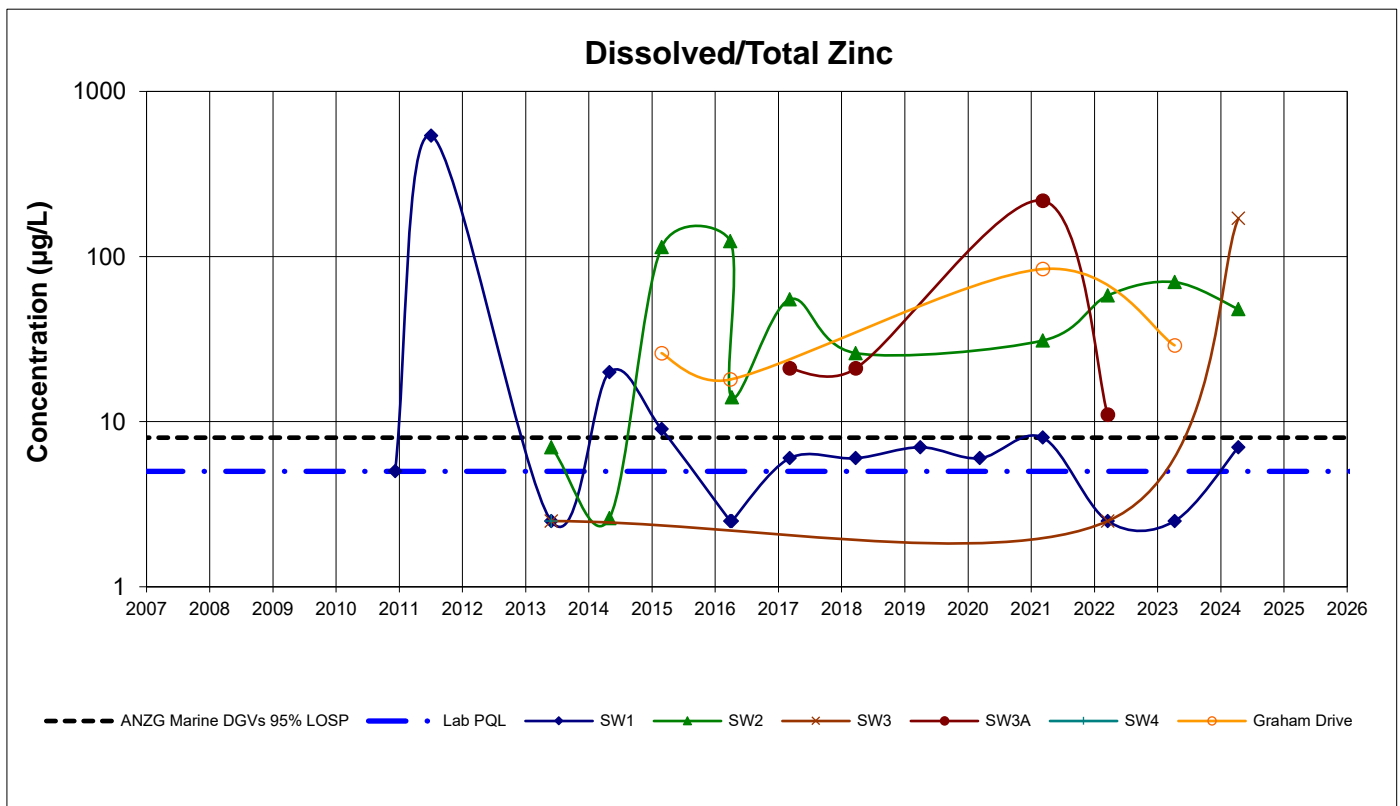
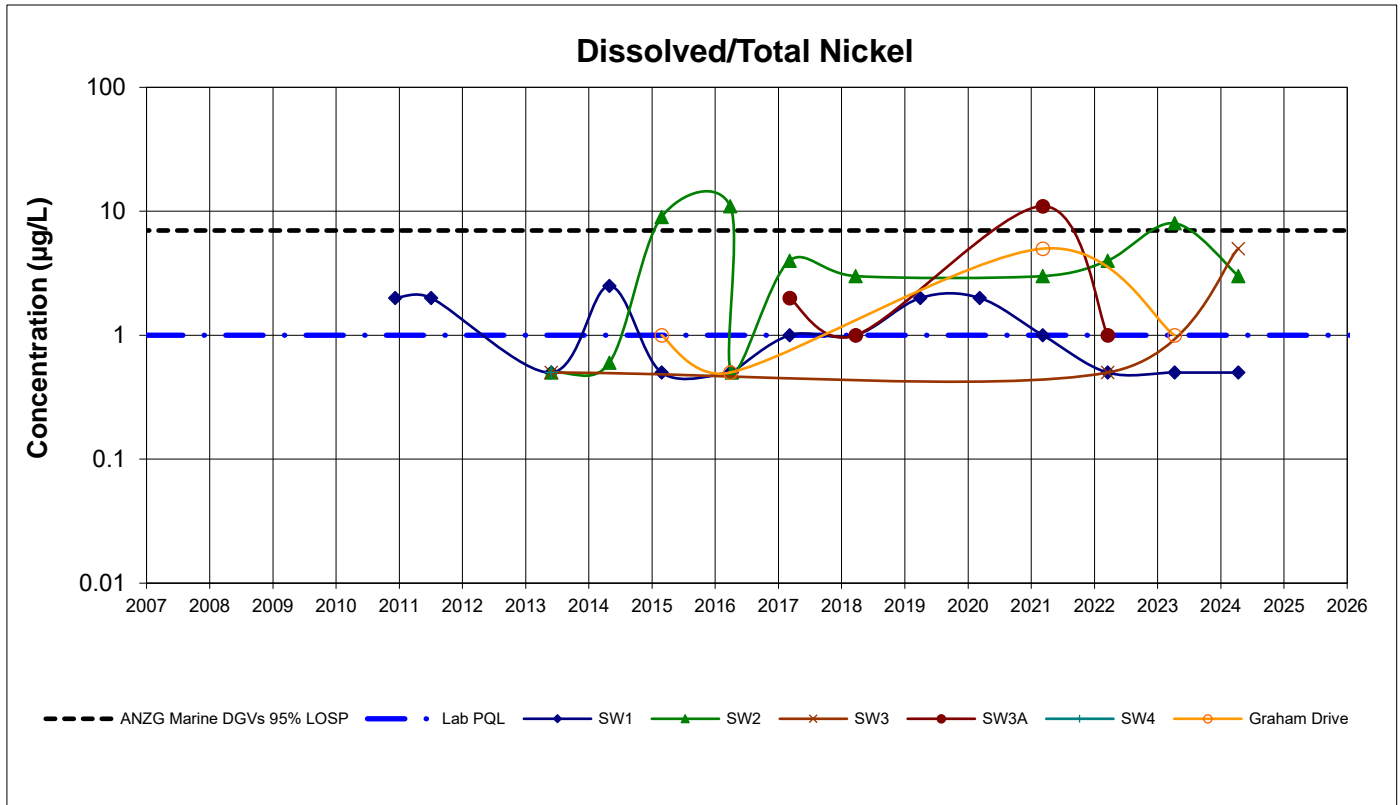

1. Values reported below PQL are plotted as half PQL
2. If a Criterion line is not plotted, there is no published criteria
3. ANZG - Marine water guideline values

SURFACE WATER QUALITY MONITORING
Tomago Northbank Enterprise Hub
Data Period: 2007 to January 2025

Data set: All data

Project: 39920.09

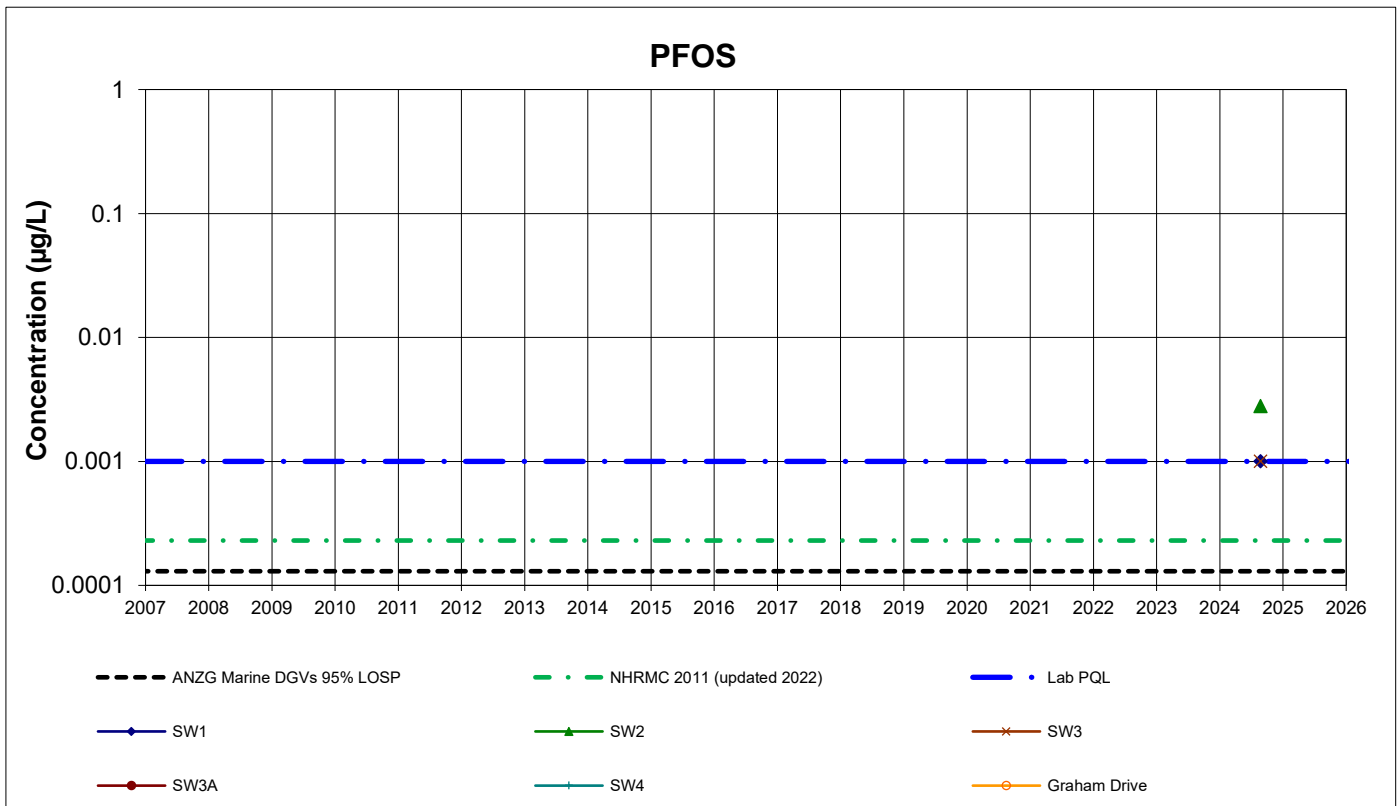
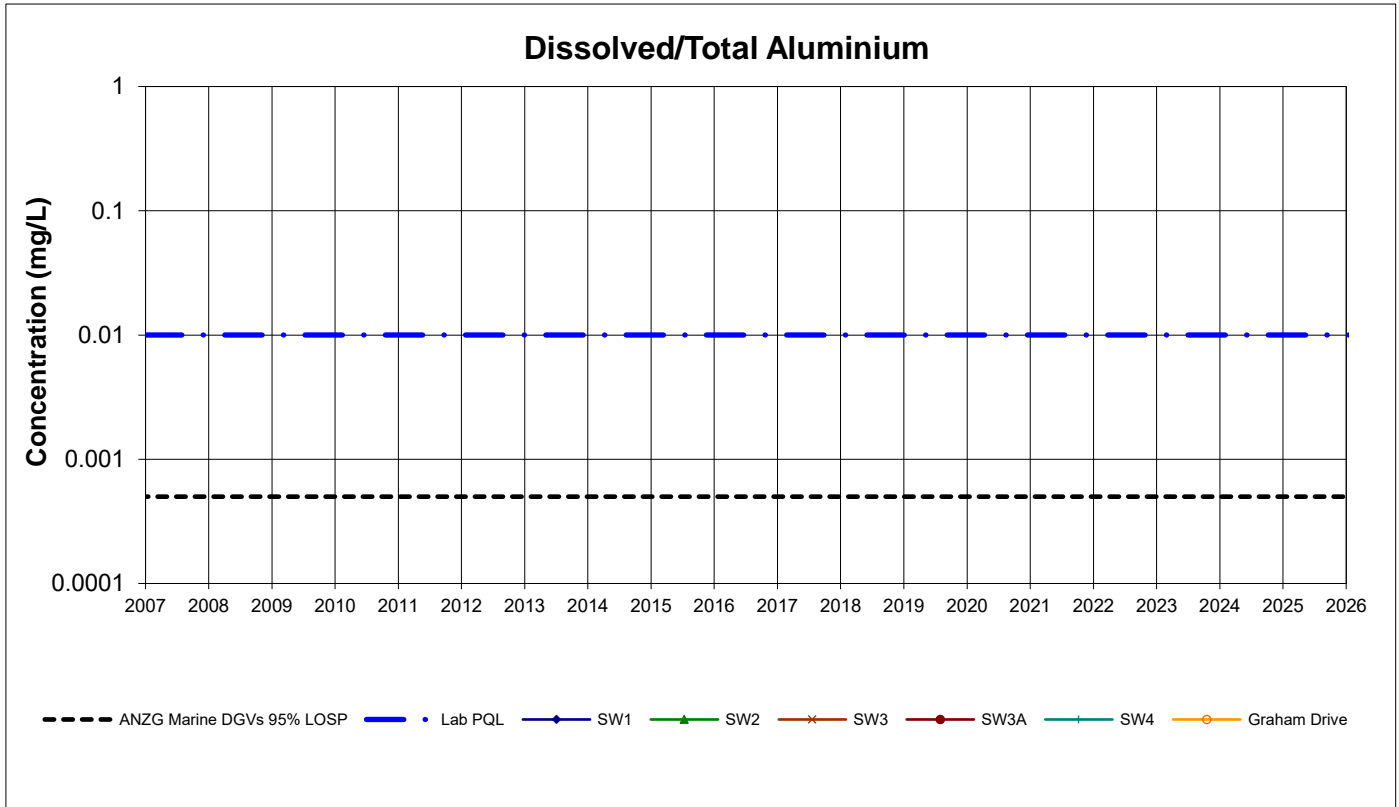

1. Values reported below PQL are plotted as half PQL
2. If a Criterion line is not plotted, there is no published criteria
3. ANZG - Marine water guideline values

SURFACE WATER QUALITY MONITORING
Tomago Northbank Enterprise Hub
Data Period: 2007 to January 2025

Data set: All data

Project: 39920.09

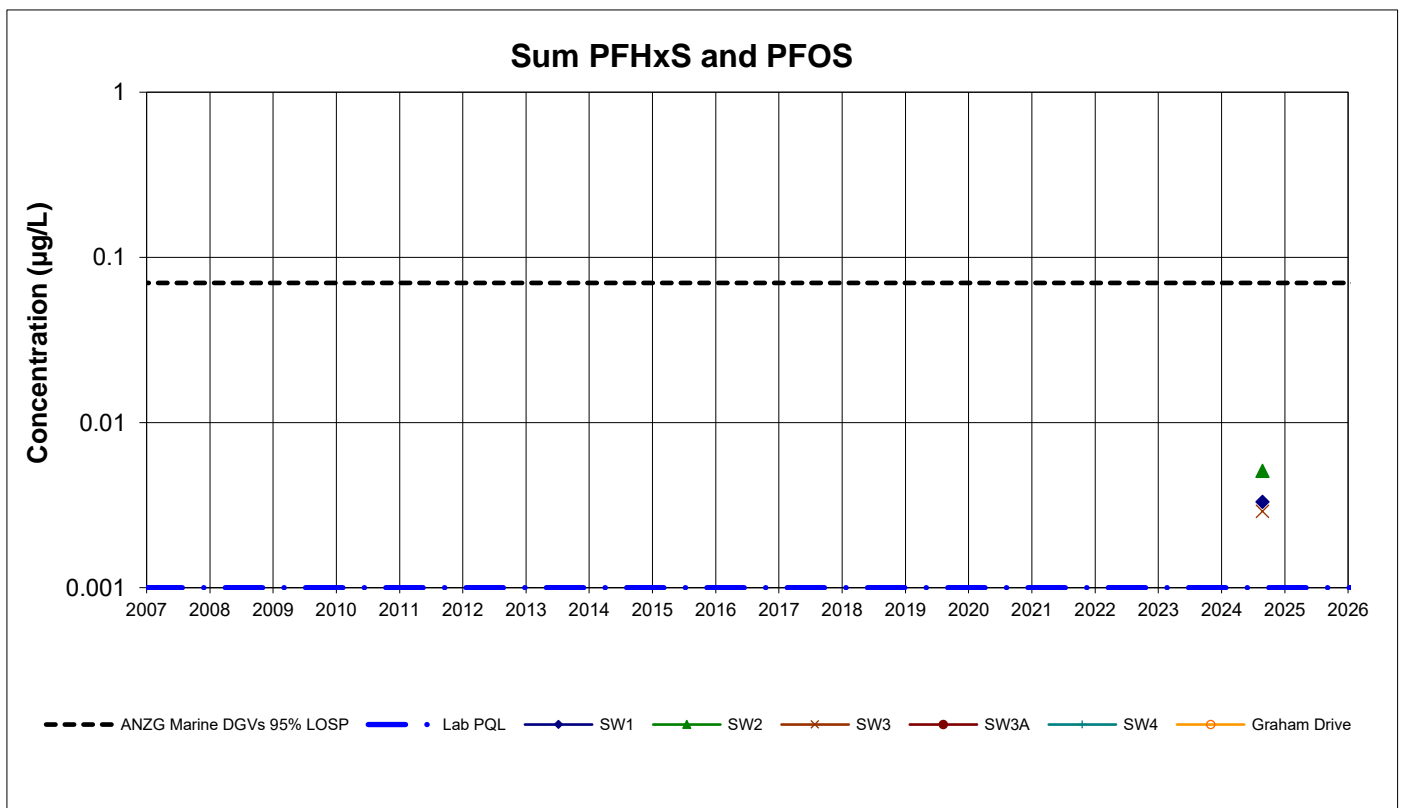
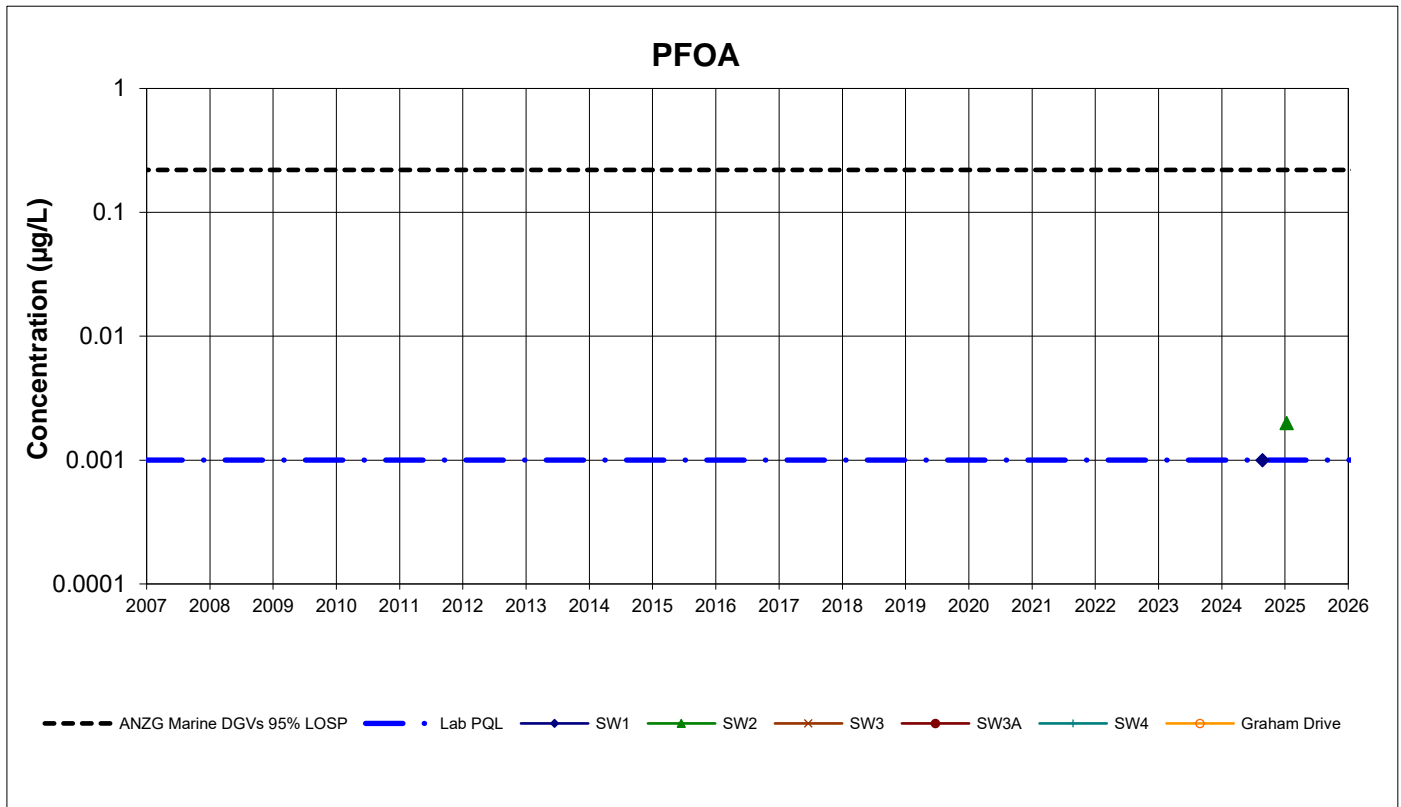

1. Values reported below PQL are plotted as half PQL
2. If a Criterion line is not plotted, there is no published criteria
3. ANZG - Marine water guideline values

SURFACE WATER QUALITY MONITORING
Tomago Northbank Enterprise Hub
Data Period: 2007 to January 2025

Data set: All data

Project: **39920.09**

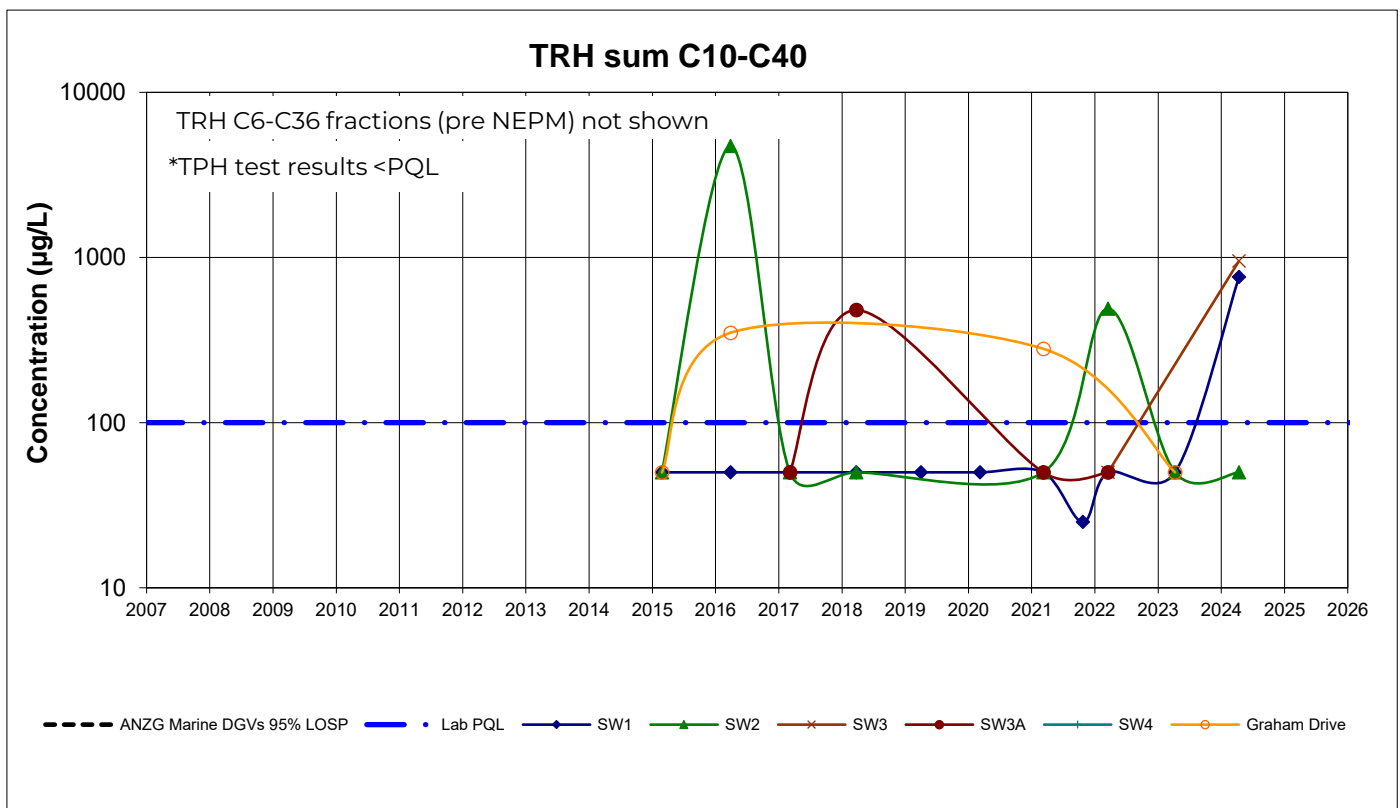
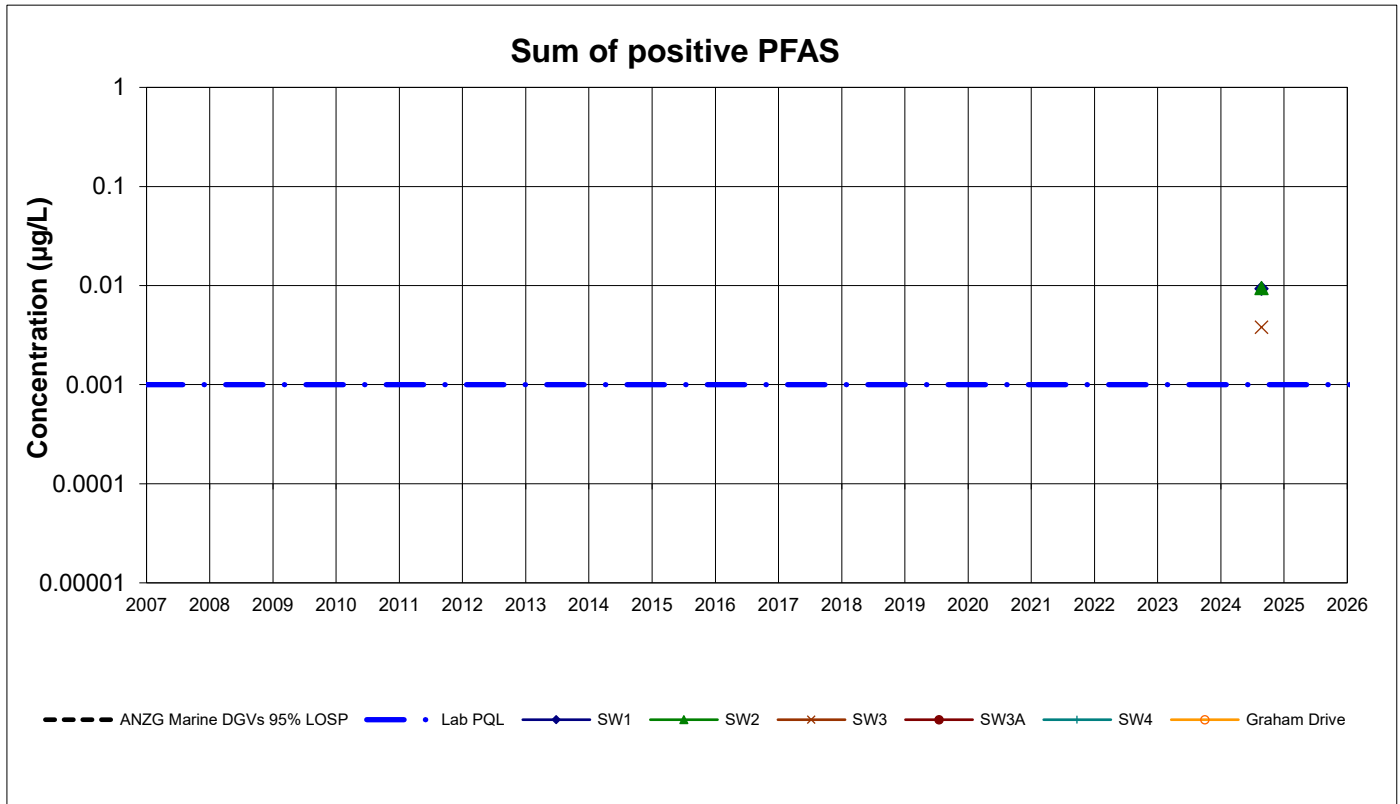

1. Values reported below PQL are plotted as half PQL
2. If a Criterion line is not plotted, there is no published criteria
3. ANZG - Marine water guideline values